



2026

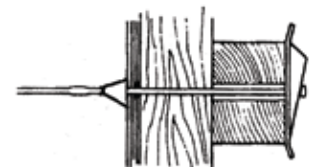
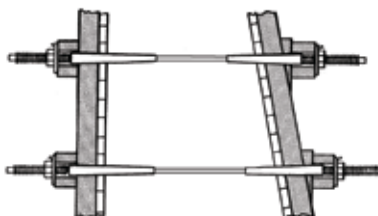
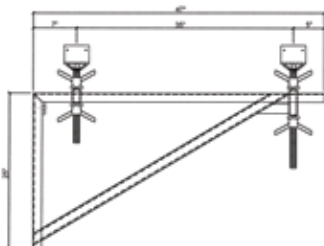
SPECTRUM CONCRETE PRODUCTS, LLC
Concrete Accessories & Steel Fabrication

***The Best Choice for Concrete
Accessories & Steel Fabrication!***

CORPORATE OFFICE:

13407 Yorba Avenue
Chino, CA 91710

Phone 909-590-0066
Fax 909-590-0061



TERMS & CONDITIONS OF SALES

PAYMENT TERMS: NET 30 DAYS

ALL ORDERS ARE SUBJECT TO A \$25.00 MINIMUM NET AMOUNT.

ALL RETURNS FOR CREDIT MUST BE APPROVED PRIOR TO RETURN, AND ARE SUBJECT TO INSPECTION AND A RESTOCKING FEE.

PRICES ARE SUBJECT TO CHANGE WITHOUT NOTICE.

SET-UP CHARGES MAY APPLY TO SMALL QUANTITY PURCHASES.

ALL PRICES ARE F.O.B. SHIPPING POINT.

AN ADDITIONAL FEE MAY BE ADDED TO FREIGHT CHARGES FOR SPECIAL PACKAGING OR HANDLING.

CUSTOMER MUST NOTIFY SPECTRUM 24 HOURS PRIOR TO RETURNING RENTAL ITEMS AND ARE RESPONSIBLE FOR FREIGHT COSTS.

ORDERS CAN BE CANCELLED BY MUTUAL AGREEMENT BETWEEN THE CUSTOMER AND SPECTRUM AND COULD BE SUBJECT TO A CANCELLATION FEE.

MINIMUM SAFETY FACTORS OF FRAMEWORK PRODUCTS

Spectrum Concrete Products, LLC strongly recommends that the provisions of the American Concrete Institute's "Recommended Practice for Concrete Formwork" (A.C.I. 347-88) be followed by all persons and organizations working in the concrete industry. We also advise that the safety factors in Table 1.3.1., below, be strictly adhered to. If there are unusual jobsite conditions, where there may be vibration, shock, or impact, safety factors should be increased.

MINIMUM SAFETY FACTORS OF FORMWORK PRODUCTS

<u>PRODUCT</u>	<u>APPROX. SAFETY FACTOR</u>	<u>TYPE OF USE</u>
<i>FORM TIES</i>	<i>2 TO 1</i>	<i>ALL FORMWORK APPLICATIONS</i>
<i>FORM ANCHORS</i>	<i>2 TO 1</i>	<i>FORMWORK SUPPORTING FORM WEIGHT AND CONCRETE ONLY</i>
	<i>3 TO 1</i>	<i>FORMWORK SUPPORTIN WEIGHT OF FORMS, CONCRETE CONSTRUCTION LIVE LOADS, AND IMPACT</i>
<i>LIFTING PLATES</i>	<i>5 TO 1</i>	<i>HARDWARE USED FOR LIFTING AND HANDLING OF TILT-UP OR PRECAST CONCRETE ITEMS</i>

It is apparent from a study of the table that the safety factor that should be applied to a given product is a variable, depending upon the degree of hazard involved in the application of the product. It is the users responsibility to determine the applicable safety factor as a function of the "Type of Construction" listed above and space accordingly. Safe working loads for form ties in this price list are shown with a safety factor of 2 to 1 in accordance with A.C.I. 347-88 recommendations shown in the table above.

Safe Working Load: The maximum working load that should be applied to any forming product.

Safety Factor: The theoretical reserve capability defined by dividing the ultimate load of the product by its SWL. This is expressed as a ration, such as 2:1 or 2 to 1.

SAFETY, CHANGES & WARRANTIES

PRODUCT SAFETY: Spectrum Concrete Products, LLC guarantees its products, as shipped from its factory and when the safety factors are taken into account. These products are intended for use by qualified and experienced persons. The slightest misuse, misapplication, or lack of supervision and inspection can contribute to serious accidents, injury, or death. Unusual applications of the products in this price list should be field-tested before general product use.

WELDING BY OTHERS: Spectrum Concrete Products, LLC does not guarantee any of its products that are welded by others. Welding to castings, and or wire products, can cause embrittlement at the load point, and can greatly reduce the load carrying capacity. Welding can also cause changes to original sizes and shapes of certain products.

CHANGES IN PRODUCT DESIGN: Spectrum Concrete Products, LLC reserves the right to change product designs, safe load ratings, and product dimensions at any time without prior notice to users. Such changes will be made only for product improvement or additional safety.

WORN WORKING PARTS: In order to maintain maximum safety, products manufactured by Spectrum Concrete Products, LLC must be properly used and maintained. The working parts in this price list are subject to overloading, misuse, wear, alteration, corrosion, deformation, and other factors which may affect the working parts safe working load. All working parts must be regularly inspected by the user, to determine if they may be used at the rated safe working load or removed from service. The frequency of inspections is dependant upon factors such as frequency of use, environment, period of use, and is best determined by the user consistent with good industry standard practice.

DO NOT straighten bent bolts, or form ties, discard and replace them. Discard any bolts known to have been used at 70% or more of their ultimate strength. Such bolts may have been stretched sufficiently enough to have become brittle-hard. It is the responsibility of every user to establish a control method to replace bolts after a predetermined number of uses, regardless of their exterior appearance.

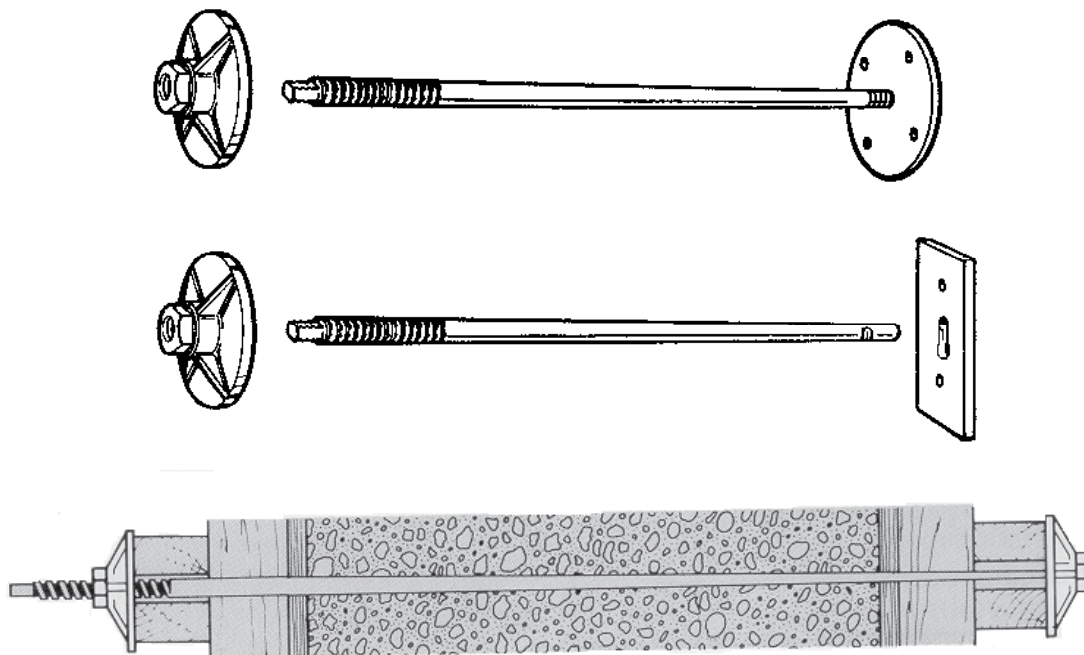
INTERCHANGEABILITY: Many of the products manufactured or distributed by Spectrum Concrete Products, LLC are designed as a system. Therefore it cannot guarantee the interchangeability with products made by others. Products manufactured by Spectrum Concrete Products, LLC used with those manufactured by others, may be rendered inefficient, or un-safe. When in doubt about proper usage or safety factors, please contact one of our customer service representatives for clarification.

WARRANTY: Spectrum Concrete Products, LLC will credit the price of, or replace at its discretion, any product which it finds defective, provided the product has not been misused. Except as previously stated, Spectrum Concrete Products, LLC assumes no liability for delay caused by defects, for loss of use, for any charges or expenses of any kind incurred without its written consent.

The foregoing statement covers the full extent of responsibility of Spectrum Concrete Products, LLC even though they may have been negligent.

TAPER TIES

- 3/4" TO 1/2" - COIL, NC OR ACME THREAD
- KEYPLATE SLOT ALSO AVAILABLE



SAFE LOAD	LARGE END	SMALL END	TIE LENGTH
6,000	3/4" X 10" COIL OR ACME THREAD	1/2" X 2" COIL OR ACME THREAD	34"
6,000	3/4" X 10" COIL OR ACME THREAD	1/2" X 2" COIL OR ACME THREAD	43"
6,000	3/4" X 10" COIL OR ACME THREAD	1/2" X 2" COIL OR ACME THREAD	52"
6,000	3/4" X 10" COIL OR ACME THREAD	1/2" X 2" COIL OR ACME THREAD	61"
4,500	3/4" X 10" COIL OR ACME THREAD	1/2" KEYPLATE SLOT	34"
4,500	3/4" X 10" COIL OR ACME THREAD	1/2" KEYPLATE SLOT	43"
4,500	3/4" X 10" COIL OR ACME THREAD	1/2" KEYPLATE SLOT	52"
4,500	3/4" X 10" COIL OR ACME THREAD	1/2" KEYPLATE SLOT	61"
APPROXIMATE 2 TO 1 SAFETY FACTOR			

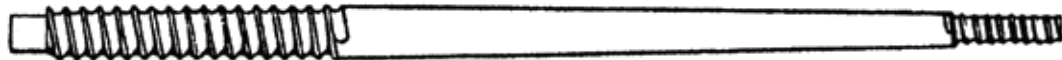
CODE	SIZE	WEIGHT	THREADED / KEYPLATE APPROX. SWL 2:1
TT3434	34"	3.0/EA	6,000 / 4,500
TT3443	43"	4.0/EA	6,000 / 4,500
TT3452	52"	4.7/EA	6,000 / 4,500
TT3461	61"	5.4/EA	6,000 / 4,500

THIS PRODUCT REQUIRES PROPER ENGINEERING

TAPER TIES, HEAVY DUTY***COIL, EURO OR ACME THREAD***

LENGTH	1" X 3/4" DIA.	1-1/4" X 1" DIA.	1-1/2" X 1-1/4" DIA.
	18,000LBS SWL 2:1 WEIGHT	34,000LBS SWL 2:1 WEIGHT	50,000LBS SWL 2:1 WEIGHT
30"	5.5/EA	8.6/EA	11.5/EA
36"	6.6/EA	10.3/EA	14.5/EA
42"	7.7/EA	12.0/EA	16.9/EA
48"	8.8/EA	13.7/EA	19.3/EA
54"	9.9/EA	15.5/EA	21.7/EA
60"	11.0/EA	17.2/EA	24.1/EA
72"	13.2/EA	20.6/EA	29.0/EA

**THIS PRODUCT REQUIRES PROPER ENGINEERING
SAFE WORKING LOADS ARE APPROXIMATE TO A 2:1 SAFETY FACTOR**

***SUPER HIGH STRENGTH TAPER TIES***

- APPROXIMATE SAFE WORKING LOAD = 75,000
- 1-1/2" COIL THREAD
- TAPERED FROM 1-3/4" TO 1-1/2"

CALL FOR SPECIAL PRICING

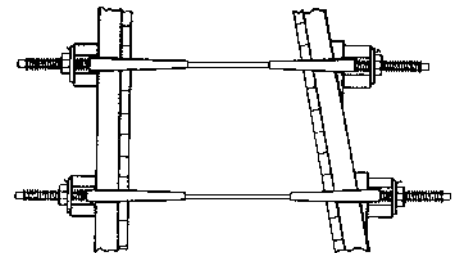
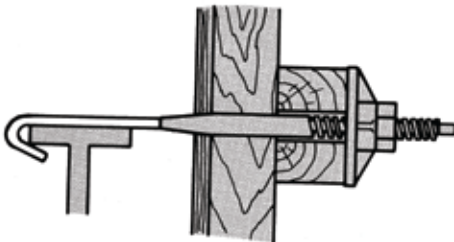
SHE BOLTS, WALER RODS

CODE	SIZE	THREAD	TAPPED	WEIGHT
SB341034A	3/4" X 10-3/4"	ACME	1/2" N.C.	1.35/EA
SB3417A	3/4" X 17"	ACME	1/2" N.C.	2.13/EA
SB3420A	3/4" X 20"	ACME	1/2" N.C.	2.5/EA
SB3424A	3/4" X 24"	ACME	1/2" N.C.	3.0/EA
SB341034C	3/4" X 10-3/4"	COIL	1/2" COIL	1.35/EA
SB3417C	3/4" X 17"	COIL	1/2" COIL	2.13/EA
SB3420C	3/4" X 20"	COIL	1/2" COIL	2.5/EA
SB3424C	3/4" X 24"	COIL	1/2" COIL	3.0/EA
SB11420	1-1/4" X 20"	COIL OR ACME	3/4" COIL	5.6/EA
SB11424	1-1/4" X 24"	COIL OR ACME	3/4" COIL	7.0/EA
SB11430	1-1/4" X 30"	COIL OR ACME	3/4" COIL	9.1/EA
SB11436	1-1/4" X 36"	COIL OR ACME	3/4" COIL	12.8/EA
SB11220	1-1/2" X 20"	COIL OR ACME	1" COIL	8.3/EA
SB11224	1-1/2" X 24"	COIL OR ACME	1" COIL	10.2/EA
SB11230	1-1/2" X 30"	COIL OR ACME	1" COIL	13.2/EA
SB11236	1-1/2" X 36"	COIL OR ACME	1" COIL	16.0/EA

THIS PRODUCT REQUIRES PROPER ENGINEERING

7/8" AND 1" OUTSIDE DIAMETER COIL THREAD AVAILABLE ON REQUEST

5/8" DIAMETER COIL TAP AVAILABLE ON REQUEST



SHE-BOLT DIAMETER	3/4"	1-1/4"	1-1/2"
APPROX S.W.L.-Tension (lbs.)	9,000	18,000	37,500
Inside Tap Diameter	1/2"	3/4"	1"
Thread Type Available	Acme or Coil	Coil	Coil
APPROXIMATE 2 TO 1 SAFETY FACTOR			

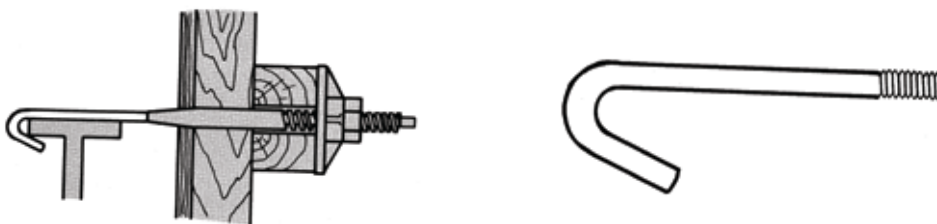
SUPER HIGH STRENGTH SHE BOLTS



- **APPROX. SAFE WORKING LOAD = 56,000 2 TO 1 SAFETY FACTOR**
- 1-1/2" COIL THREAD OUTER, 1-1/4" COIL INNER TAP
- AVAILABLE IN ANY LENGTH

CALL FOR SPECIAL PRICING

J-BOLTS



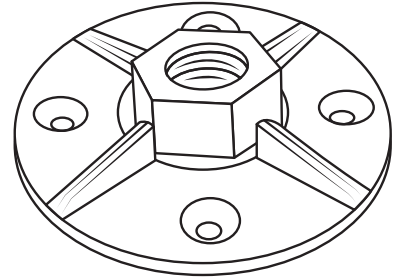
- **UNEMBEDDED TENSION LOAD= 800LBS, 2:1 APPROX. SAFETY FACTOR**

CODE	SIZE	WEIGHT	PACKAGED
JBOL02	1/2" X 2" NC	15.0/C	100/BOX
JBOL03	1/2" X 3" NC	20.0/C	100/BOX
JBOL04	1/2" X 4" NC	25.0/C	100/BOX
JBOL06	1/2" X 6" NC	32.0/C	100/BOX
JBOL02C	1/2" X 2" COIL	15.0/C	100BOX
JBOL03C	1/2" X 3" COIL	20.0/C	100BOX
JBOL04C	1/2" X 4" COIL	25.0/C	100BOX
JBCL06C	1/2" X 6" COIL	32.0/C	100BOX
JBOL344C	3/4" X 4" COIL	88.0/C	100BOX
JBOL345C	3/4" X 5" COIL	110.0/C	100BOX
JBOL346C	3/4" X 6" COIL	113.0/C	100BOX

THIS PRODUCT REQUIRES PROPER ENGINEERING

NUT WASHERS, CATHEADS

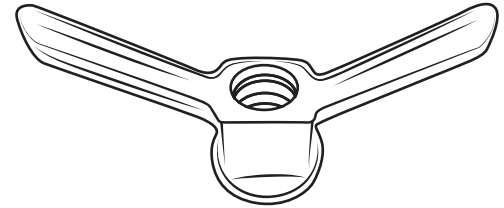
- NC AVAILABLE UPON REQUEST



AVAILABLE IN ACME & COIL THREAD

CODE	SIZE	WEIGHT
NTWSH12A	1/2" ACME	.75/EA
NTWSH12C	1/2" COIL	.75/EA
NTWSH34A	3/4" ACME	.75/EA
NTWSH34C	3/4" COIL	.75/EA

THIS PRODUCT REQUIRES PROPER ENGINEERING

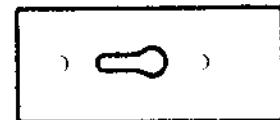
COIL WING NUTS

CODE	SIZE	WEIGHT
WIN012	1/2" COIL	.65/EA
WIN034	3/4" COIL	.90/EA
WIN100	1" COIL	1.07/EA
WIN114	1-1/4" COIL	1.22/EA
WIN112	1-1/2" COIL	2.85/EA

THIS PRODUCT REQUIRES PROPER ENGINEERING

KEYPLATES

- 5/16" X 2" X 6"
- THREADED KEYPLATES ALSO AVAILABLE

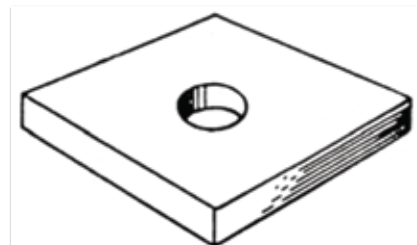


CODE	SIZE	WEIGHT
KEYPLT	1/2" SLOTTED	1.0/EA

THIS PRODUCT REQUIRES PROPER ENGINEERING

PLATE WASHERS

- HOLE SIZE IS MADE 1/16" LARGER THAN BOLT DIAMETER.



AVAILABLE WITH ANY SIZE BOLT DIAMETER.
OTHER SIZES AVAILABLE ON REQUEST.

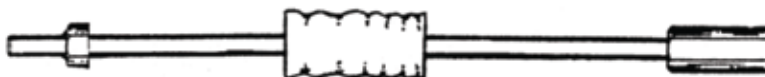
SIZE	WEIGHT
1/4" X 4" X 4"	1.14/EA
3/8" X 5" X 5"	2.65/EA
1/2" X 5" X 5"	3.3/EA
1/2" X 6" X 6"	4.95/EA
5/8" X 6" X 6"	6.35/EA
3/4" X 7" X 7"	10.25/EA
3/4" X 8" X 8"	13.5/EA

THIS PRODUCT REQUIRES PROPER ENGINEERING

BATTER WASHERS

CODE	SIZE	WEIGHT
BTWSH34	3/4"	2.5/EA
BTWSH10	1"	4.0/EA
BTWSH114	1-1/4"	5.5/EA
BTWSH112	1-1/2"	8.0/EA

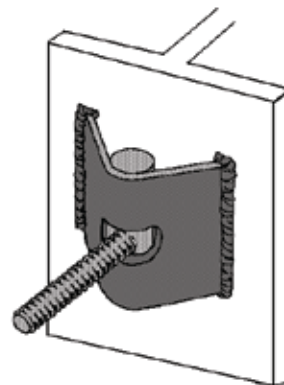
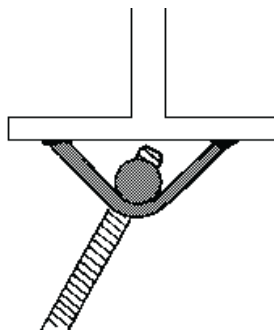
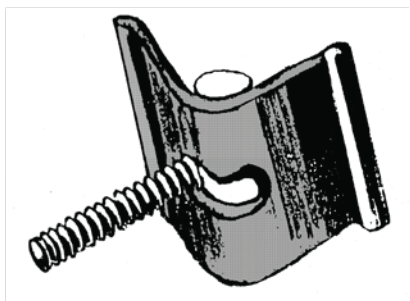
THIS PRODUCT REQUIRES PROPER ENGINEERING

SHE BOLT PULLERS

CODE	THREAD	WEIGHT
RODPLR	COIL OR ACME	15.0/EA

WELDED ANGLE BRACKETS

- FOR BLIND WALL FORMING
- COIL ROD/EURO ROD NOT INCLUDED
- BOTH STANDAD & HEAVY DUTY AVAILABLE

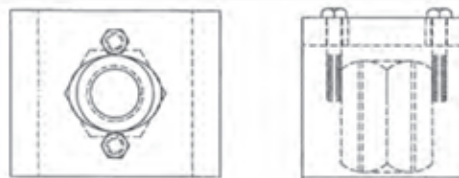


CODE	SIZE	WEIGHT
WAB012	1/2" COIL	2.6/EA
WAB058	5/8" COIL	3.2/EA
WAB034	3/4" COIL	3.2/EA
WAB100	1" COIL	7.2/EA
WAB058E	5/8" EURO	3.2/EA
WAB078E	7/8" EURO	5.1/EA

THIS PRODUCT REQUIRES PROPER ENGINEERING

MIKE BRACKETS

- FOR BLIND WALL FORMING
- HEAVY DUTY STYLE
- EURO THREAD AVAILABLE



CODE	SIZE	WEIGHT
MIKE34	3/4"	4.0/EA
MIKE10	1"	4.6/EA
MIKE14	1-1/4"	5.2/EA

THIS PRODUCT REQUIRES PROPER ENGINEERING

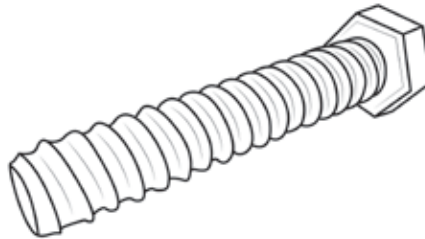
FIT-UP BOLT ASSEMBLY

SPECIAL SPEED THREAD 3/4" X 2" BOLT AND 3/4" HEX NUT, ALLOWS FOR QUICK FASTENING AND BUTTONING-UP OF VARIOUS TYPES OF FORMS. ASSEMBLY INCLUDES ONE NUT AND ONE BOLT.



- 4" AVAILABLE UPON REQUEST

CODE	SIZE	WEIGHT
FITBLT	3/4" X 2"	.35/EA
FITNUT	3/4"	.15/EA

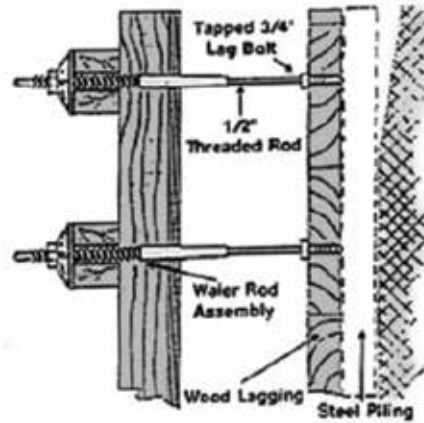
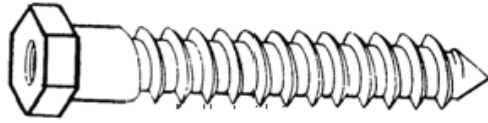
COIL BOLTS

- FULLY WELDED COIL BOLTS AVAILABLE UPON REQUEST.

LENGTH	1/2" DIAMETER	3/4" DIAMETER	1" DIAMETER
	WEIGHT	WEIGHT	WEIGHT
2"	12.0/C	31.0/C	55.0/C
2-1/2"	15.0/C	37.0/C	66.0/C
3"	17.5/C	43.0/C	77.0/C
3-1/2"	20.0/C	49.0/C	88.0/C
4"	23.0/C	55.0/C	110.0/C
5"	28.5/C	67.0/C	132.0/C
6"	34.0/C	78.0/C	154.0/C
7"	39.5/C	90.0/C	176.0/C
8"	41.0/C	102.0/C	198.0/C
9"	45.5/C	114.0/C	220.0/C
10"	46.5/C	126.0/C	242.0/C
11"	52.0/C	138.0/C	264.0/C
12"	57.5/C	150.0/C	286.0/C
ADD ON PER INCH	5.5/C	12.0/C	22.0C

THIS PRODUCT REQUIRES PROPER ENGINEERING

TAPPED LAG BOLTS



TIMBER SIZE	*APPROX. SAFE WORKING LOAD 2:1	PILOT HOLE SIZE
2" X 10"	1,575 LBS.	9/16"
3-3/4" or 4" X 12" TREATED	3,500 LBS.	9/16"

*SAFE WORKING LOAD IS APPROXIMATE, QUALITY OF LUMBER WILL AFFECT STRENGTH

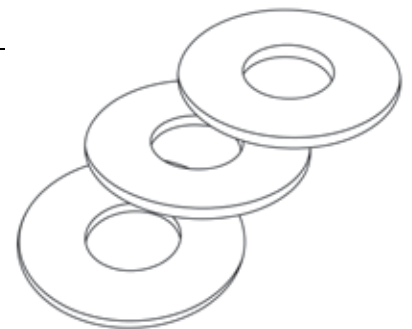
- SIMPLIFIES FOUNDATION WALL FORMING
- SPEEDS CONCRETE POURS
- REDUCES EXTERNAL BRACING

CODE	SIZE	WEIGHT	PACKAGED
TPLGNC	3/4" X 5" N.C.	.67/EA	EACH
TPLGCO	3/4" X 5" COIL	.67/EA	EACH

THIS PRODUCT REQUIRES PROPER ENGINEERING

CUT WASHERS, US WASHERS

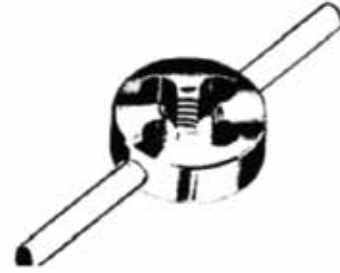
CODE	SIZE	APPROX NO. IN 100 LBS	APPROX NET WT. LBS PER 1000 PIECES
WASH12	1/2"	2,600	38.5
WASH58	5/8"	1,300	77
WASH34	3/4"	910	110
WASH10	1"	530	188
WASH114	1-1/4"	380	260
WASH112	1-1/2"	260	385



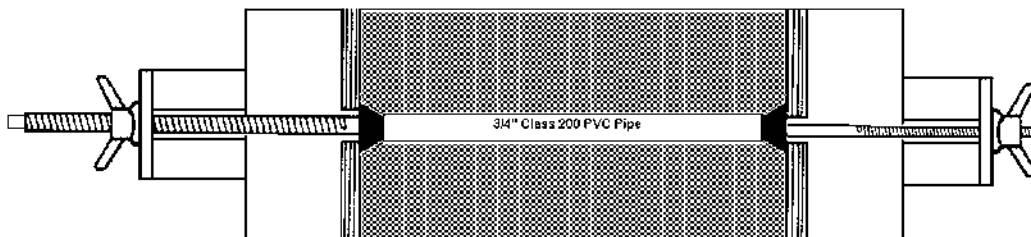
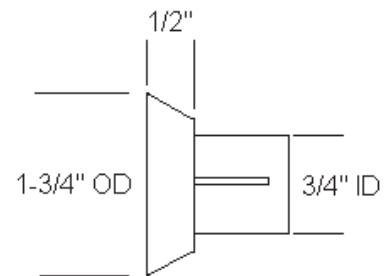
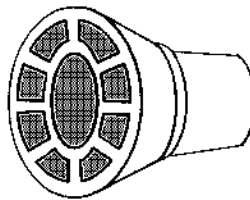
NEOPRENE WATERSEALS

CODE	SIZE
NEO012	1/2"
NEO058	5/8"
NEO034	3/4"
NEO100	1"
NEO114	1-1/4"
NEO112	1-1/2"



THREAD CHASERS

CODE	SIZE	WEIGHT
CHA012	1/2"	2.25/EA
CHA034	3/4"	2.25/EA
CHA100	1"	2.25/EA
CHA114	1-1/4"	2.25/EA
CHA112	1-1/2"	2.25/EA

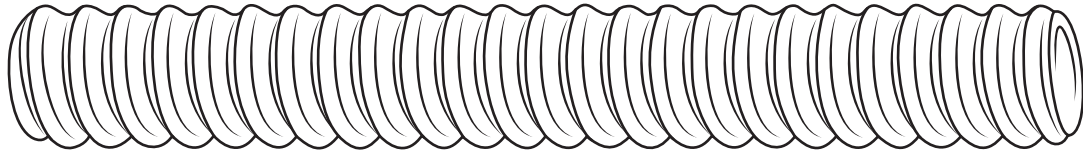
PUSH-FIT CONES

THIS SPREADER CONE IS USED WITH 3/4", CLASS 200 PVC PIPE, TO ALLOW THREADED ROD TO PASS THROUGH THE CONCRETE UNTOUCHED. CONES ARE REUSABLE.

CODE	WEIGHT	PACKAGED
PUSHFIT	1.25/C	500/BOX

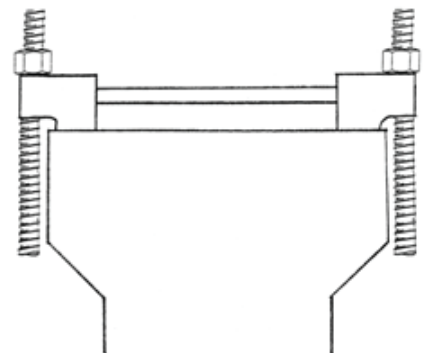
HI-TENSILE COIL ROD

- STOCKED IN 12 FOOT LENGTHS
- LEFT-HAND THREAD AVAILABLE



DIAMETER	CODE
1/2"	COR012
5/8"	COR058
3/4"	COR034
1"	COR100
1-1/4"	COR114
1-1/2"	COR112

THIS PRODUCT REQUIRES PROPER ENGINEERING

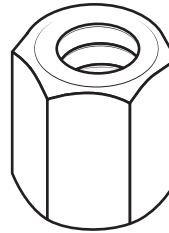
***TECHNICAL DATA***

Diameter	1/2"	5/8"	3/4"	1"	1-1/4"	1-1/2"
APPROX. S.W.L.-Tension (lbs.)	9,000	12,000	18,000	38,000	56,000	68,000
APPROX. S.W.L.-Shear (lbs.)	6,000	8,000	12,000	25,300	37,500	45,300
Min. Coil Penetration	2"	2-1/4"	2-1/4"	2-1/2"	2-1/2"	3"
Pounds per foot:	0.53	0.85	1.15	2.04	3.47	6.01
Safe Working Load is based on approximately a 2 to 1 factor.						

COIL NUTS

CODE	SIZE	WEIGHT	PACKAGED
CON012	1/2"	6.0/C	1000/BOX
CON058	5/8"	11.0/C	1000/BOX
CON034	3/4"	18.0/C	500/BOX
CON100	1"	40.0/C	150/BOX
CON114	1-1/4"	76.0/C	270/BOX
CON112	1-1/2"	151.0/C	50/BOX

THIS PRODUCT REQUIRES PROPER ENGINEERING

HEAVY HEX COIL NUTS

CODE	SIZE	WEIGHT
HVYHEX12	1/2"	23.0/C
HVYHEX58	5/8"	28.0/C
HVYHEX34	3/4"	30.0/C
HVYHEX10	1"	54.0/C
HVYHEX114	1-1/4"	150.0/C
HVYHEX112	1-1/2"	275.0/C

THIS PRODUCT REQUIRES PROPER ENGINEERING

TECHNICAL DATA

DIAMETER	1/2"	5/8"	3/4"	1"	1-1/4"	1-1/2"
S.W.L.-TENSION (lbs.) Using One Nut	6,000	6,000	9,000	18,000	27,000	40,500
S.W.L.-TENSION (lbs.) Using Two Nuts or One Heavy Nut	9,000	12,000	18,000	37,500	56,000	67,500
DIM. ACROSS FLATS	7/8"	1-1/8"	1-1/4"	1-5/8"	2"	2-3/8"
Safe Working Load is based on approximately a 2 to 1 Safety Factor						

LEFT-HAND COIL NUTS ARE AVAILABLE UPON SPECIAL REQUEST

ADJUSTABLE COIL BOLTS

- ONE RUNNING NUT INCLUDED



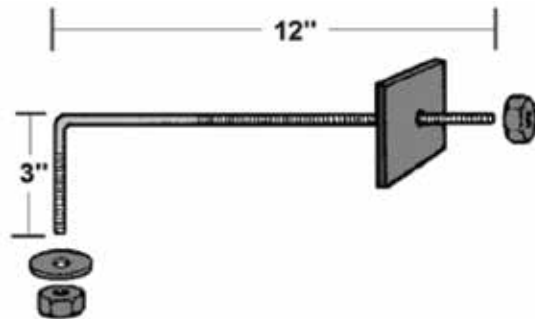
CODE	SIZE	WEIGHT
ACB121	1/2" X 18"	95.0/C
ACB122	1/2" X 24"	120.0/C
ACB123	1/2" X 36"	173.0/C
ACB341	3/4" X 18"	197.7/C
ACB342	3/4" X 24"	255.2/C
ACB343	3/4" X 36"	370.2/C

**THIS PRODUCT REQUIRES PROPER ENGINEERING
SET-UP CHARGE MAY APPLY FOR LESS THAN 100**

WALER BOLT ASSEMBLY

Assembly Includes:

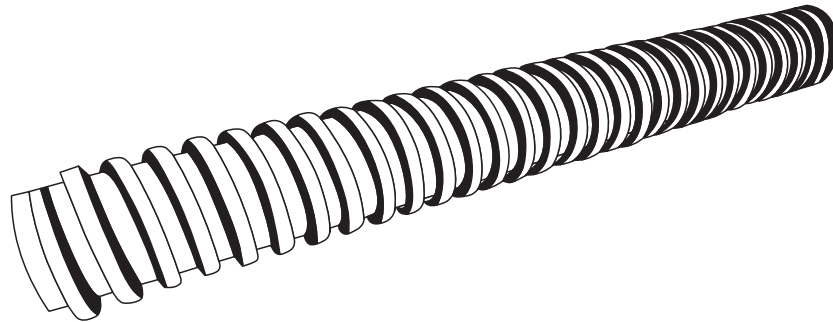
- 1ea. L-Rod, Coil Threaded
- 2 ea. 1/2" Coil Nuts
- 1 ea 1/2" Cut Washer
- 1 ea 1/4"x3"x4" Plate Washer



DIAMETER	WEIGHT	PACKAGED
1/2" COIL	174.0/C	EACH

ACME THREADED ROD

- 12' STANDARD LENGTHS
- SPECIAL ORDER ONLY

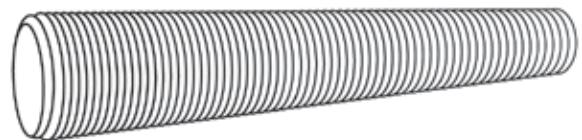


CODE	SIZE	WEIGHT
ACR012	1/2"	53.0/CLF
ACR034	3/4"	115.0/CLF
ACR100	1"	204.0/CLF
ACR114	1-1/4"	348.0/CLF
ACR112	1-1/2"	601.0/CLF

THIS PRODUCT REQUIRES PROPER ENGINEERING

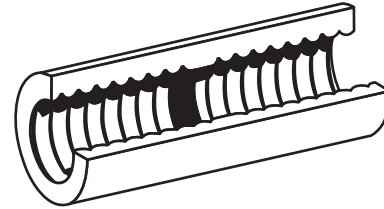
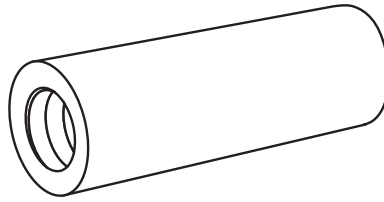
ALL THREAD ROD, NC ROD

- 12' STANDARD LENGTH
- LOW CARBON
- AVAILABLE PLAIN OR PLATED
- OTHER LENGTHS AVAILABLE UPON REQUEST



CODE	DIAMETER	WEIGHT
NCR012	1/2"	0.53/EA
NCR058	5/8"	0.85/EA
NCR034	3/4"	1.15/EA
NCR100	1"	2.04/EA

COIL COUPLERS



Positive Stop in the Center

CODE	SIZE	APPROX SWL 2:1	WEIGHT
COU012	1/2" X 2-1/2"	9,000 LBS.	20.0/C
COU058	5/8" X 3"	12,000 LBS.	35.0/C
COU034	3/4" X 3"	18,000 LBS.	40.0/C
COU100	1" X 4-1/2"	38,000 LBS.	150.0/C
COU114	1-1/4" X 5-1/2"	56,000 LBS.	280.0/C
COU112	1-1/2" X 7"	67,500 LBS.	430.0/C

THIS PRODUCT REQUIRES PROPER ENGINEERING

INNER RODS

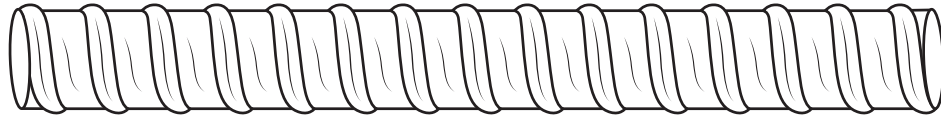
- APPROX. SAFE WORKING LOAD = 2 TO 1
- MADE WITH FLAT SPOT



Inner Rod w/optional waterseal

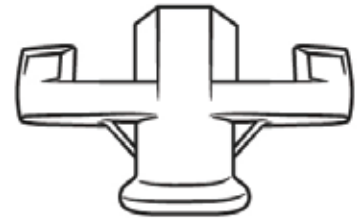
TIE LENGTH	1/2" HI-TENSILE COIL OR N.C. THREAD	3/4" HI-TENSILE COIL OR N.C. THREAD	1" HI-TENSILE COIL OR N.C. THREAD
	**9,000LBS S.W.L.	**18,000LBS S.W.L.	**38,000LBS S.W.L.
	WEIGHT	WEIGHT	WEIGHT
Up to 6"	27.0/C	60.0/C	106.0/C
7"	32.0/C	70.0/C	124.0/C
8"	37.0/C	81.0/C	142.0/C
9"	41.0/C	90.0/C	159.0/C
10"	45.0/C	100.0/C	177.0/C
11"	50.0/C	111.0/C	195.0/C
12"	54.0/C	120.0/C	212.0/C
13"	58.0/C	130.0/C	230.0/C
14"	63.0/C	141.0/C	248.0/C
15"	67.0/C	150.0/C	265.0/C
16"	72.0/C	160.0/C	283.0/C
17"	77.0/C	171.0/C	301.0/C
18"	81.0/C	180.0/C	318.0/C
ADD ON PER 1" OVER 18"	4.3/C	10.1/C	18.0/C

WATERSEAL WASHERS AVAILABLE UPON REQUEST
**** SAFE WORKING LOAD IS APPROXIMATE TO A 2:1 SWL**

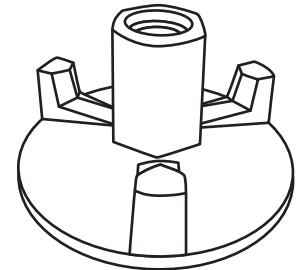
EURO ROD

CODE	DIAMETER	WT/LBS./FT.	S.W.L. (LBS.)
EUR058	5/8" (15mm)	1.0	20,000
EUR078	7/8" (20mm)	1.55	32,000

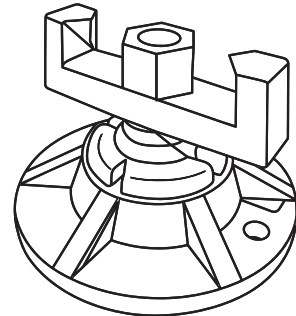
SAFE WORKING LOAD IS APPROXIMATE TO A 2:1 SAFETY FACTOR

EURO WING NUTS

CODE	SIZE	WEIGHT
EWN058	5/8"	.60 EA
EWN078	7/8"	.80 EA

EURO WING NUTS w/PLATE

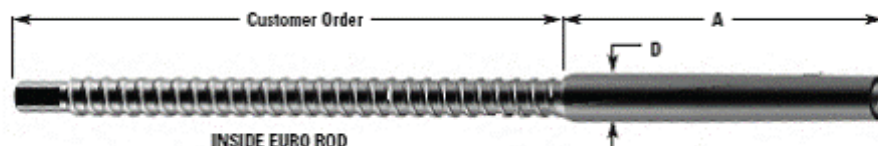
CODE	SIZE	WEIGHT
EWNP58	5/8"	1.5 EA
EWNP78	7/8"	2.5 EA

EURO SWIVEL WING NUTS

CODE	SIZE	WEIGHT
EWN58S	5/8"	2.1/EA
EWN78S	7/8"	3.4/EA

EURO SHE BOLTS

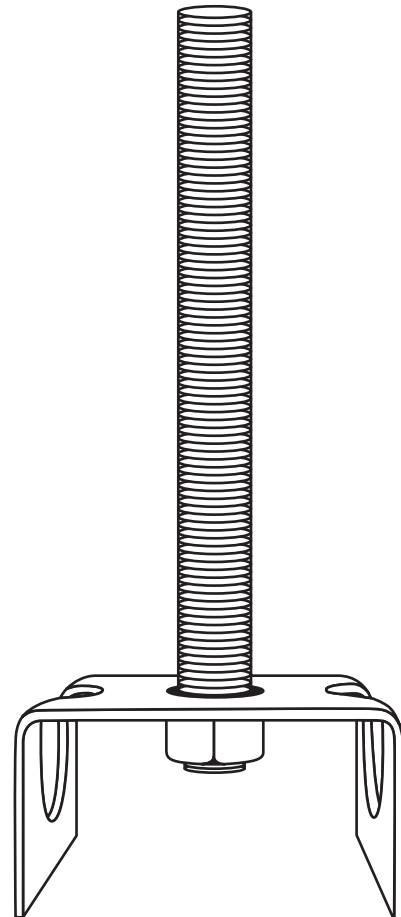
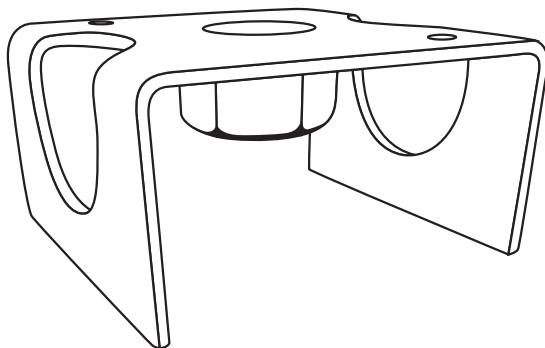
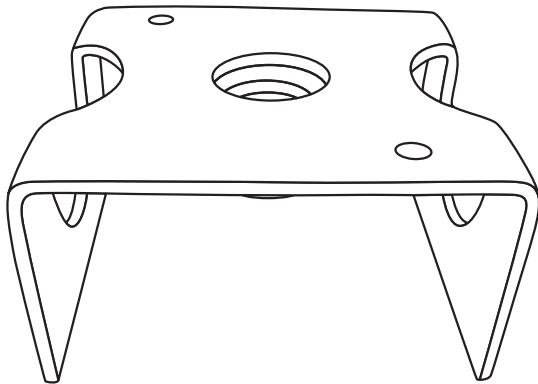
INSIDE ROD DIAMETER	APPROX S.W.L.	A	D
5/8"	18,000	7-3/4"	1"
7/8"	32,750	7-3/4"	1-3/4"



BOLT STANDS

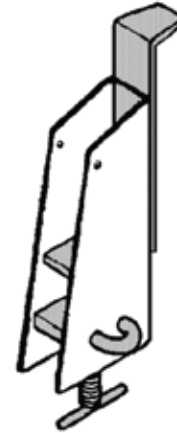
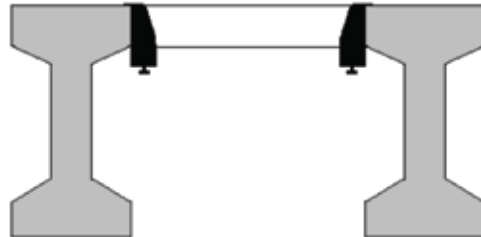
- HOLDS ANCHOR BOLTS SECURELY IN PLACE.
- ALLOWS CONCRETE TO FLOW FREELY.
- A HEAVY HEX NUT IS WELDED TO THE FORMED BODY.
- INSTALL WITH EITHER NAILS OR SCREWS.
- AVAILABLE IN NC OR COIL THREAD
- GALVANIZED

CODE	SIZE	WEIGHT
BS12WN	1/2"	0.323/EA
BS58WN	5/8"	0.36/EA
BS34WN	3/4"	0.433/EA
BS78WN	7/8"	0.553/EA
BS100WN	1"	0.693/EA
BS118WN	1-1/8"	0.803/EA
BS114WN	1-1/4"	1.101/EA
BS112WN	1-1/2"	1.52/EA



ADJUSTABLE JOIST HANGERS

- SAFE WORKING LOAD = 3,000 LBS. APPROX. 2 TO 1 SAFETY FACTOR
- FOR INTERIOR SPANS ONLY, NOT TO BE USED ON EXTERIOR CANTILEVERED DECK SLABS.



CODE	SIZE	WEIGHT
AJH2X	2 X JOINT	6.0/EA

THIS PRODUCT REQUIRES PROPER ENGINEERING

STEEL RIB, PERMANENT FORMWORK

PRODUCT CODE	STLRIB
SHEET SIZE	27" X 97"
SURFACE / SHEET	18 SQ. FT.
THICKNESS	26 GA.
WEIGHT PER SHEET	11.90 LBS.
RIB SIZE	3/4"
RIB SPACE	3.80"
PALLET QUANTITY	250 SHEETS



- ALLOWS A HIGH RATE OF RISE IN CONCRETE
- MINIMIZES PREPARATION OF THE JOINT SURFACE SO REINFORCEMENT PLACING CAN CONTINUE WITHOUT A BREAK
- SAVES TIME. IT'S LEFT IN PLACE SO FORMWORK STRIPPING IS ELIMINATED

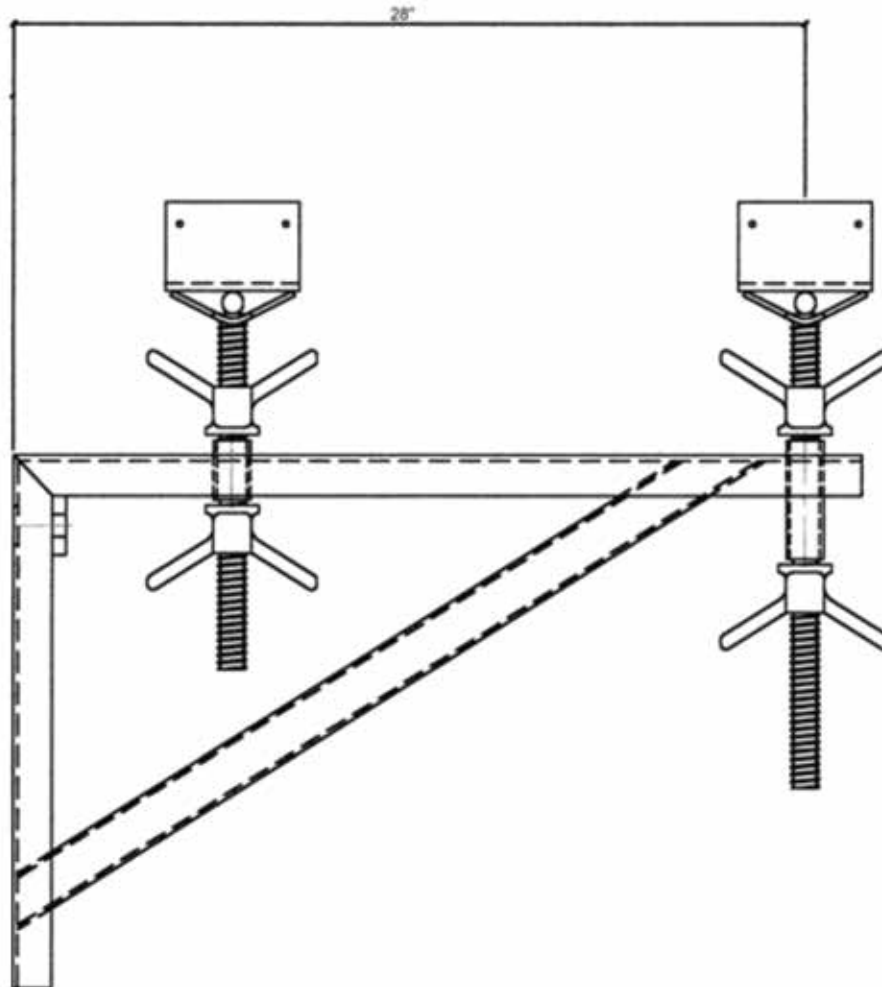
STEEL RIB TIE



CODE	WEIGHT	PACKAGED	APPROXIMATE S.W.L.
STLRIBTIE	0.430 LBS./ EA	EACH	1,800 LBS.

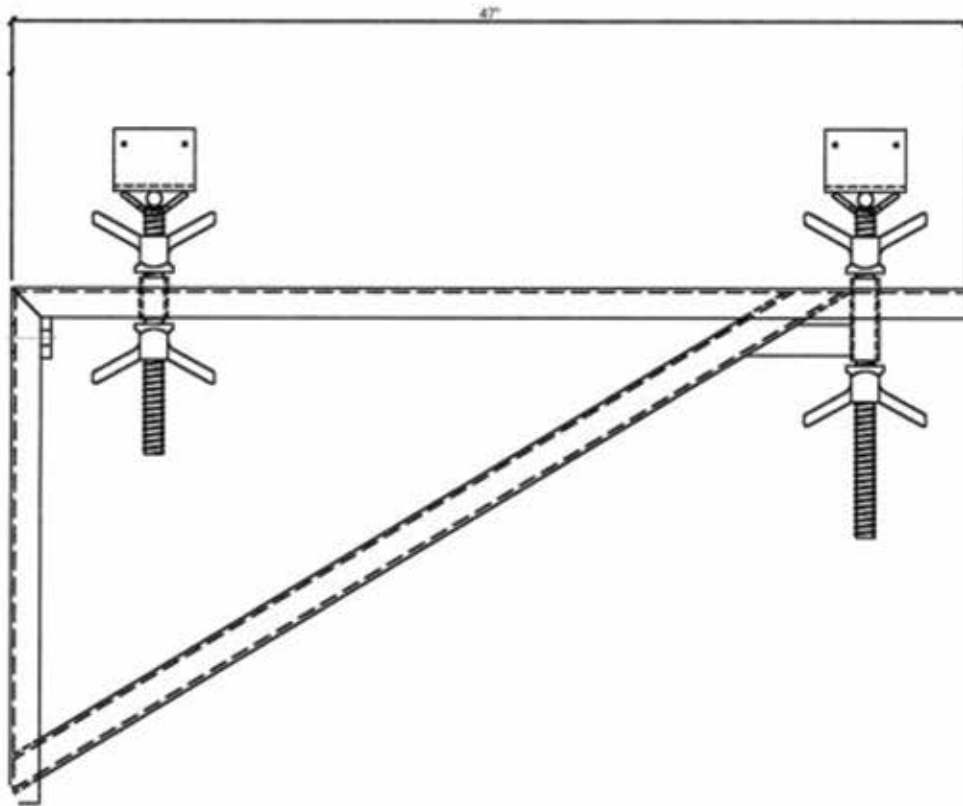
SAFE WORKING LOAD IS APPROX. BASED ON A 2:1 SAFETY FACTOR

- STEEL RIB TIES ARE MANUFACTURED WITH A NUT AND KEEPER PLATE ON ONE END AND HEADED ON THE OTHER END.
- FOR USE WITH STEEL RIB

BRIDGE OVERHANG BRACKETS**28" BRIDGE OVERHANG BRACKET**

CODE	STYLE	WEIGHT
BOHB28	28" STANDARD	40.0/EA

THIS PRODUCT REQUIRES PROPER ENGINEERING

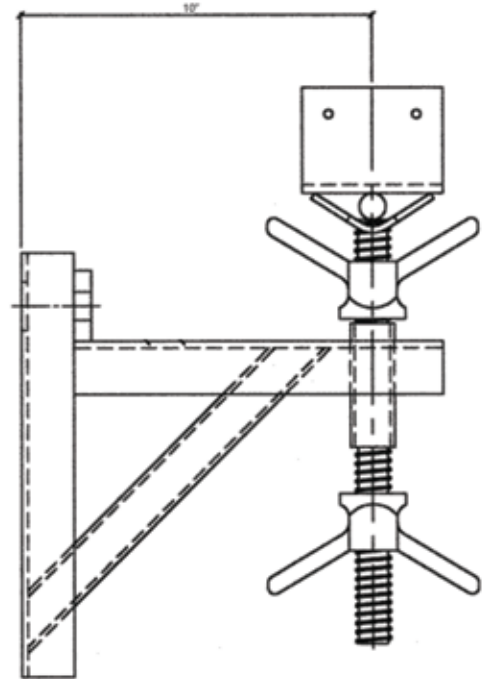
BRIDGE OVERHANG BRACKETS**42" BRIDGE OVERHANG BRACKET**

CODE	STYLE	WEIGHT
BOHB42	42" STANDARD	50.0/EA

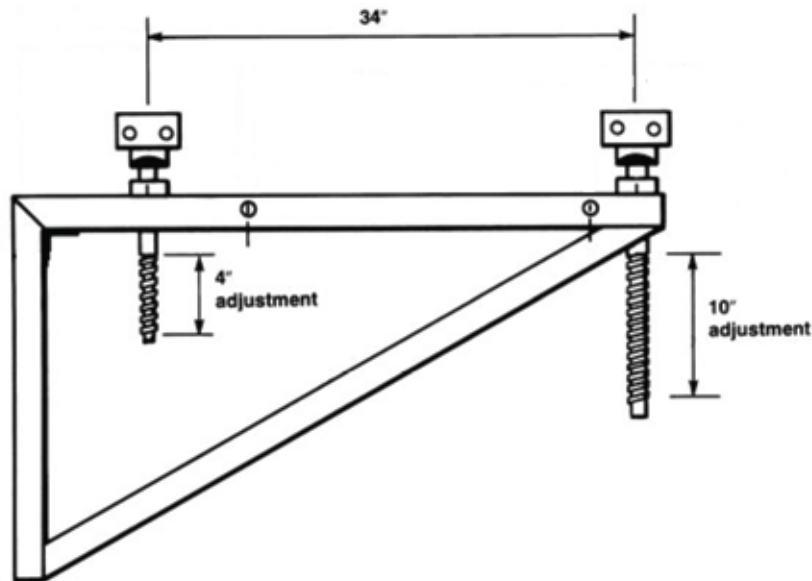
THIS PRODUCT REQUIRES PROPER ENGINEERING

BRIDGE OVERHANG BRACKETS

10" DECK SUPPORT BRACKETS



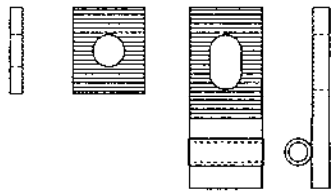
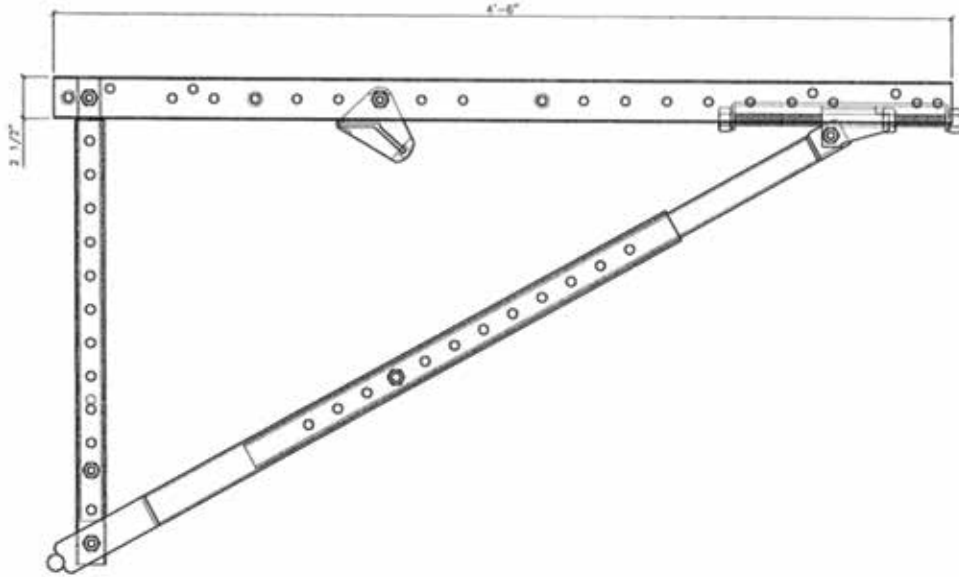
SWIVEL OVERHANG BRACKETS



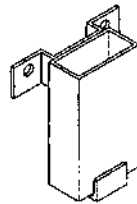
CODE	STYLE	WEIGHT
BOHB10	10" DECK SUPPORT	18.0/EA
BOHBSW	SWIVEL OVERHANG	35.0/EA
THIS PRODUCT REQUIRES PROPER ENGINEERING		

HEAVY DUTY BRIDGE OVERHANG BRACKETS

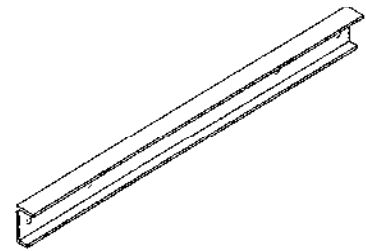
- D-49 ADJUSTABLE OVERHANG BRACKET



WALL PLATE ASSEMBLY



GUARD RAIL HOLDER



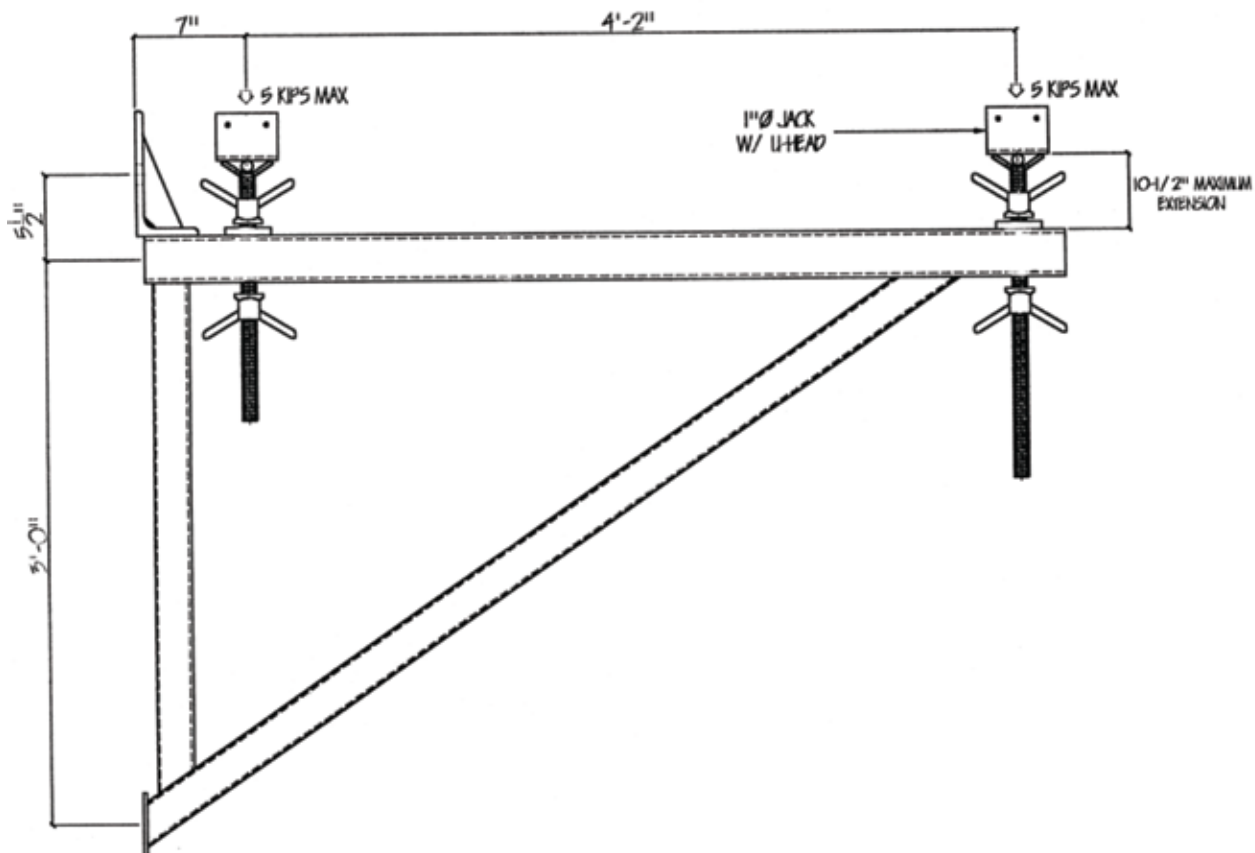
BRACKET EXTENDER

CODE	STYLE	WEIGHT
BRJD49	D-49 ADJUSTABLE BRACKET	45.0/EA
BRJD50	ADJUSTMENT PLATE ONLY	.4/EA
BRJD51	WALL BRACKET ONLY	1.35/EA
BRJD52	WALL PLATE ASSEMBLY	1.75/EA
BRJD53	2X4 GUARD RAIL HOLDER	3.5/EA
BRJD536	2X6 GUARD RAIL HOLDER	4.0/EA
BRJD54	BRACKET EXTENDER	3.0/EA

THIS PRODUCT REQUIRES PROPER ENGINEERING

HEAVY DUTY BRIDGE OVERHANG BRACKETS

- 10K SUPER OVERHANG BRACKET



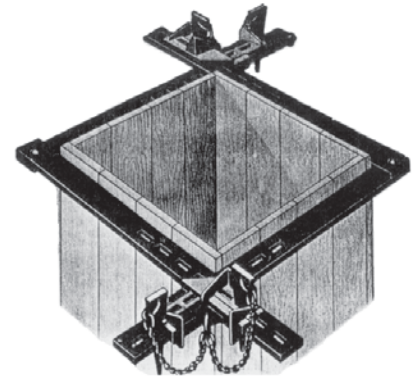
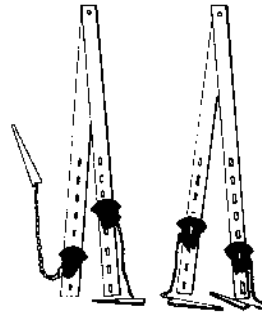
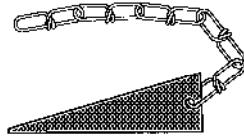
CODE	STYLE	WEIGHT
BOHB10K	10K SUPER	100.0/EA

THIS PRODUCT REQUIRES PROPER ENGINEERING

SCISSOR CLAMPS, COLUMN CLAMPS

- CLAMPS ARE IDENTICAL
- 2 PIECES PER SET
- PIN & CHAIN ASSEMBLY ALSO SOLD SEPARATELY

CODE	WEIGHT
PINCHN	1.0/EA



U.S. SYSTEM			
CLAMP SIZE	36"	48"	60"
BAR SIZE	5/16" X 2-1/2" X 36"	3/8" X 2-1/2" X 48"	3/8" X 3" X 60"
CLAMP OPENING	10-1/2" to 28"	14" to 40"	24-1/2" to 50-1/2"
WEIGHT/CLAMP*	40 lbs.	56 lbs.	85 lbs.
COLUMN SIZE**	6" to 23-1/2"	9-1/2" to 35-1/2"	20" to 46"

*Clamps are sold and rented by the piece, but two (2) pieces are required to make a useable clamp set.

**Concrete dimensions based on 3/4" (19mm) plywood with flat 2x4's (38mm x 89mm) at 6" (152mm) on center.

CODE	SIZE	COLUMN SIZE	WEIGHT
CLM036	36"	6" TO 23-1/2"	40.0/SET
CLM048	48"	9-1/2" TO 35-1/2"	56.0/SET
CLM060	60"	20" TO 46"	85.0/SET

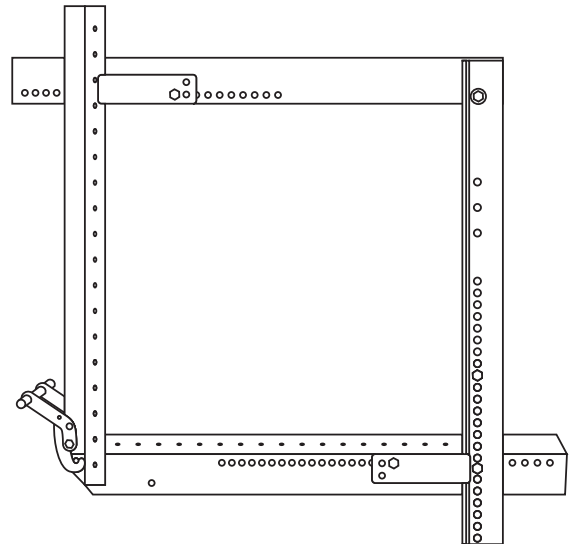
THIS PRODUCT REQUIRES PROPER ENGINEERING

RAPID-LOCK COLUMN CLAMP

- DESIGNED FOR RAPID CONCRETE PLACEMENT
- SIMPLE DESIGN FOR FAST ASSEMBLY ON JOBSITE

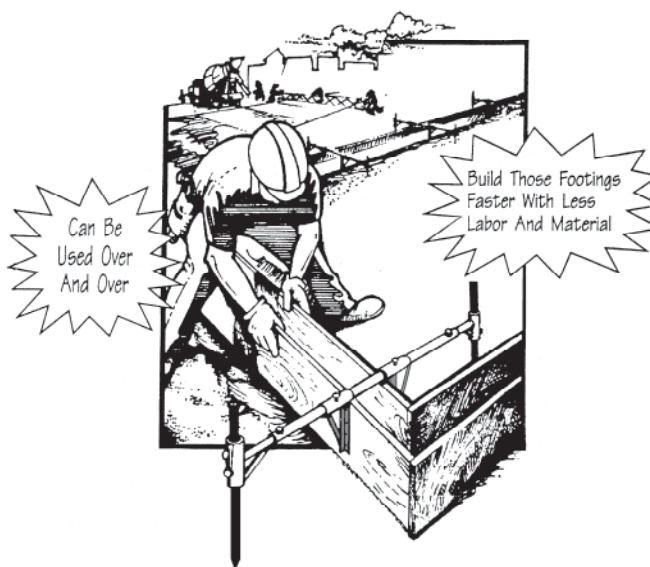
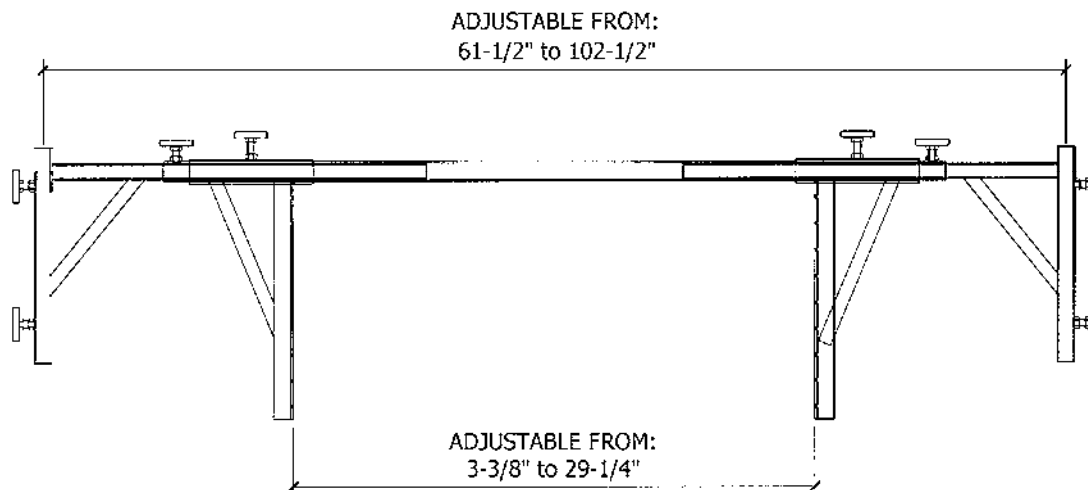
CODE	SIZE	COLUMN SIZE
RLCC824	24"	8" TO 24"
RLCC1236	36"	12" TO 36"
RLCC2448	48"	24" TO 48"

THIS PRODUCT REQUIRES PROPER ENGINEERING

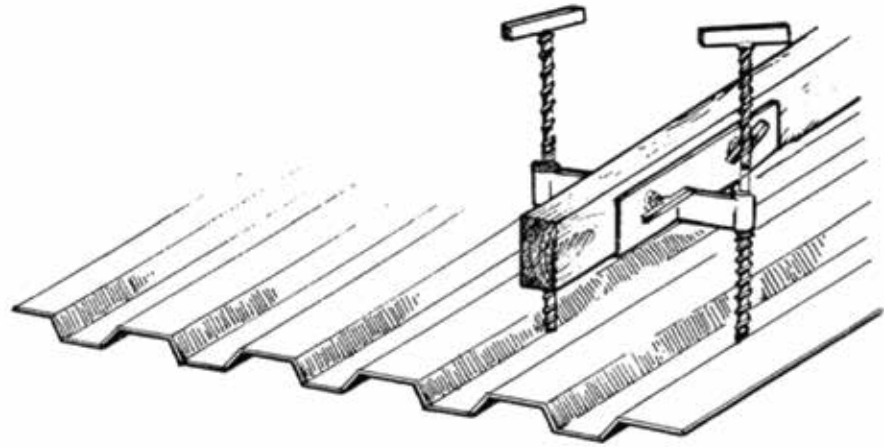


FAST SET FORM HANGERS, SCHOOL BRACKETS

- ONE PIECE ADJUSTABLE FORM HANGER
- SAVES ON LABOR AND MATERIALS
- MEETS REQUIREMENTS FOR SCHOOL AND MILITARY PROJECTS
- HIGH RE-USE FACTOR



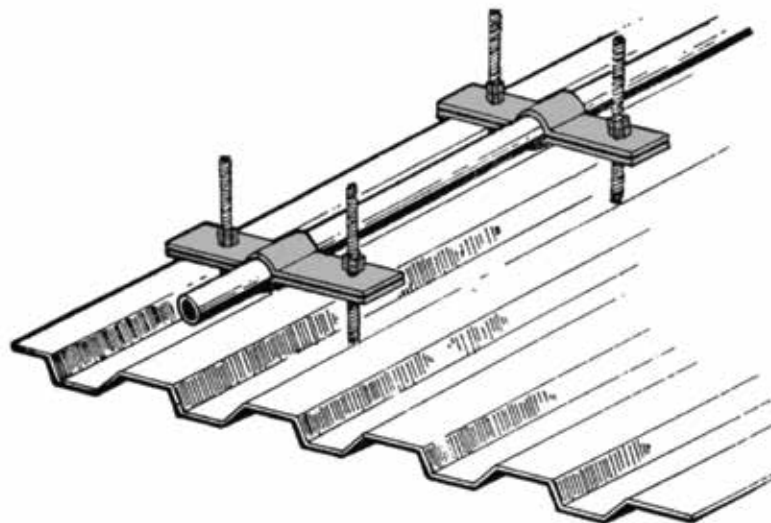
CODE	WEIGHT	PACKAGED
FSTFRM	35.0/EA	EACH

SPEED SCREEDS

CODE	WEIGHT	PACKAGED
SPDSCR	12/EA	EACH

PIPE SCREEDS / DON SCREEDS

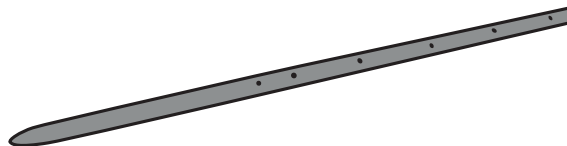
- 2" PIPE



CODE	WEIGHT	PACKAGED
PIPESCR	8.0/EA	EACH

ROUND STAKES

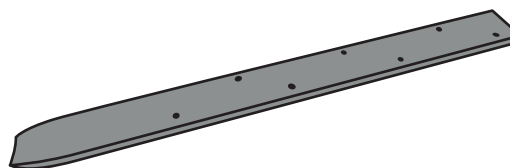
- 3/4" WITH HOLES



CODE	SIZE	WEIGHT	PACKAGED
STA012	3/4" X 12"	1.50/EA	10/BOX 1000/PALLET
STA018	3/4" X 18"	2.25/EA	10/BOX 1000/PALLET
STA024	3/4" X 24"	3.00/EA	10/BOX 1000/PALLET
STA030	3/4" X 30"	3.75/EA	10/BOX 600/PALLET
STA036	3/4" X 36"	4.50/EA	10/BOX 600/PALLET
STA048	3/4" X 48"	6.00/EA	10/BOX 500/PALLET

FLAT STAKES

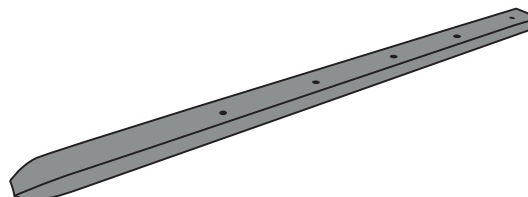
- 3/8" X 1-1/2" WITH HOLES



CODE	SIZE	WEIGHT	PACKAGED
FSTA12	3/8" X 1-1/2" X 12"	1.91/EA	10/BOX 1000/PALLET
FSTA18	3/8" X 1-1/2" X 18"	2.87/EA	10/BOX 1000/PALLET
FSTA24	3/8" X 1-1/2" X 24"	3.82/EA	10/BOX 1000/PALLET
FSTA30	3/8" X 1-1/2" X 30"	4.78/EA	10/BOX 600/PALLET
FSTA36	3/8" X 1-1/2" X 36"	5.73/EA	10/BOX 600/PALLET
FSTA48	3/8" X 1-1/2" X 48"	7.64/EA	10/BOX 400/PALLET

STAKES AVAILABLE WITHOUT HOLES ON REQUEST**FLAT STAKES**

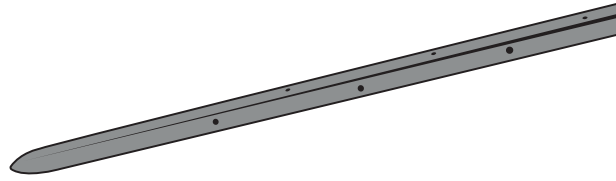
- 1/2" X 1" WITH HOLES



CODE	SIZE	WEIGHT	PACKAGED
FS1212	1/2" X 1" X 12"	1.70/EA	10/BOX 1000/PALLET
FS1218	1/2" X 1" X 18"	2.55/EA	10/BOX 1000/PALLET
FS1224	1/2" X 1" X 24"	3.40/EA	10/BOX 1000/PALLET
FS1230	1/2" X 1" X 30"	4.25/EA	10/BOX 600/PALLET
FS1236	1/2" X 1" X 36"	5.10/EA	10/BOX 600/PALLET
FS1248	1/2" X 1" X 48"	6.80/EA	10/BOX 500/PALLET

SQUARE STAKES

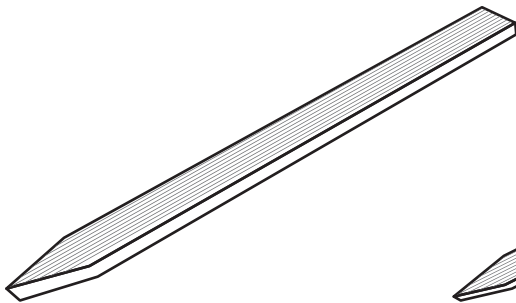
- WITH HOLES



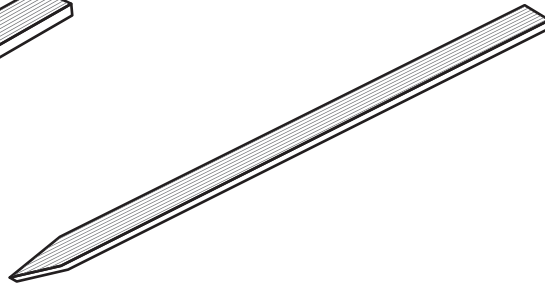
CODE	SIZE	WEIGHT	PACKAGED
SQST12	12"	1.0/EA	10/BOX 1000/PALLET
SQST18	18"	1.5/EA	10/BOX 1000/PALLET
SQST24	24"	2.0/EA	10/BOX 1000/PALLET
SQST30	30"	2.5/EA	10/BOX 600/PALLET
SQST36	36"	3.0/EA	10/BOX 600/PALLET
SQST48	48"	4.0/EA	10/BOX 500/PALLET

STAKES AVAILABLE WITHOUT HOLES ON REQUEST

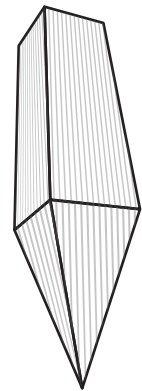
WOOD STAKES



STANDARD



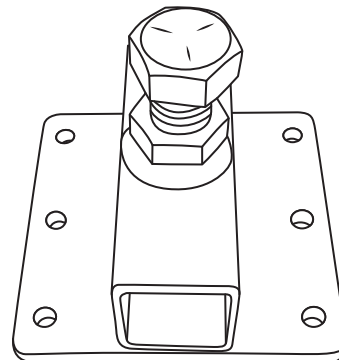
LATH



HUB

HEADER FORM BRACKETS

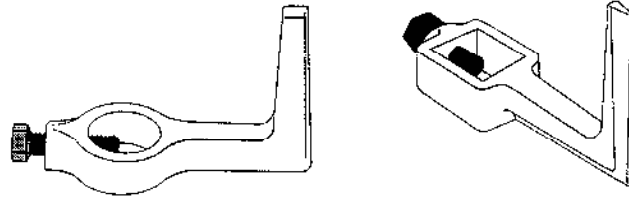
- FOR SUPPORTING HEADERS ON 3/4" ROUND OR SQUARE STAKES.



CODE	WEIGHT	PACKAGED
HDRBKT	1.0/EA	EACH

SCREED HOOKS

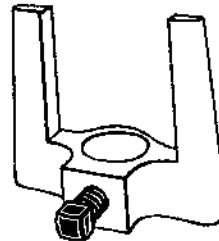
- 2" X 4" SINGLE
- 1/2" X 2" SINGLE



CODE	TYPE	WEIGHT	PACKAGED
SCH24R	2X4 RND. HOLE	.54/EA	100/BOX
SCH24S	2X4 SQ. HOLE	.54/EA	100/BOX
SCH122	1/2X2 RND.HOLE	.54/EA	100/BOX

DOUBLE SCREED HOOKS

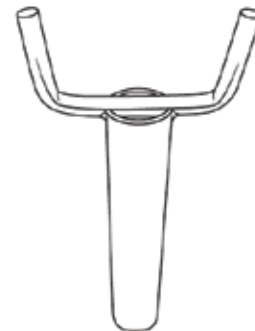
- 2" X 4" DOUBLE
- 1/2" X 2" DOUBLE



CODE	TYPE	WEIGHT	PACKAGED
DSC122	1/2X2 SQ. HOLE	.55/EA	50/BOX
DSCH24	2X4 RND. HOLE	1.4/EA	50/BOX

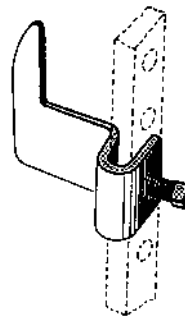
REBAR PIPE SCREED HOLDERS, #4

- HOLD UP TO 1-5/8" OD PIPE
- SPECIAL SIZES AVAILABLE UPON REQUEST



CODE	SIZE	WEIGHT
RBPSH2	2"	.12/EA
RBPSH4	4"	.20/EA

FLAT STAKE SCREED HOOKS



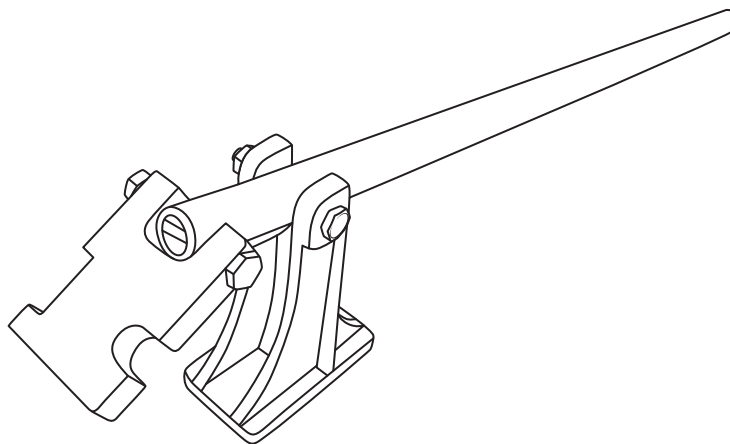
CODE	TYPE	WEIGHT	PACKAGED
FLTSCH	FLAT STAKE	.5/EA	100/BOX

WIRE SCREED HOOKS



CODE	TYPE	WEIGHT	PACKAGED
WIRSCH	WIRE	.2/EA	100/BOX

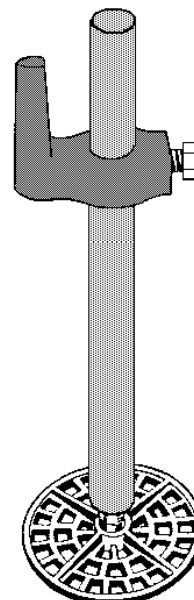
STAKE PULLERS



CODE	WEIGHT	PACKAGED
STKPLR	11.5EA	EACH

SCREED PAD POSTS

- 3/4" DIAMETER
- TAPPED 1/2" N.C.
- SCREWS ON DIE CAST SCREED PADS
- GOOD FOR PLYWOOD & STEEL DECKS
- HOLES AVAILABLE UPON REQUEST



CODE	SIZE	WEIGHT	PACKAGED
SCRPO8	3/4" X 8"	1.00/EA	EACH
SCRPO10	3/4" X 10"	1.25/EA	EACH
SCRPO12	3/4" X 12"	1.50/EA	EACH
SCRPO16	3/4" X 16"	2.00/EA	EACH
SCRPO18	3/4" X 18"	2.25/EA	EACH
SCRPO24	3/4" X 24"	3.00/EA	EACH
SCRPO30	3/4" X 30"	3.75/EA	EACH
SCRPO36	3/4" X 36"	4.50/EA	EACH

SET UP CHARGE MAY APPLY FOR LESS THAN 100 PIECE ORDERS

DIE CAST SCREED PADS

CODE	SIZE	WEIGHT	PACKAGED
SCRPDS	3" DIA., 1/2" N.C.	.16/EA	100/BOX

SCREW POINT POSTS

- HOLES AVAILABLE UPON REQUEST



CODE	SIZE	WEIGHT	PACKAGED
SCWP08	3/4" X 8"	1.00/EA	EACH
SCWP10	3/4" X 10"	1.25/EA	EACH
SCWP12	3/4" X 12"	1.50/EA	EACH
SCWP16	3/4" X 16"	2.00/EA	EACH
SCWP18	3/4" X 18"	2.25/EA	EACH
SCWP24	3/4" X 24"	3.00/EA	EACH
SCWP30	3/4" X 30"	3.75/EA	EACH
SCWP36	3/4" X 36"	4.50/EA	EACH

SET UP CHARGE MAY APPLY FOR LESS THAN 100 PIECE ORDERS

NAIL POINT POSTS

- HOLES AVAILABLE UPON REQUEST



CODE	SIZE	WEIGHT	PACKAGED
NAIL08	3/4" X 8"	1.00/EA	EACH
NAIL10	3/4" X 10"	1.25/EA	EACH
NAIL12	3/4" X 12"	1.50/EA	EACH
NAIL16	3/4" X 16"	2.00/EA	EACH
NAIL18	3/4" X 18"	2.25/EA	EACH
NAIL24	3/4" X 24"	3.00/EA	EACH
NAIL30	3/4" X 30"	3.75/EA	EACH
NAIL36	3/4" X 36"	4.50/EA	EACH

SET UP CHARGE MAY APPLY FOR LESS THAN 100 PIECE ORDERS

PIPE SCREED HOLDERS

- UP TO 1-1/4" SCH 40 PIPE
- COIL THREAD

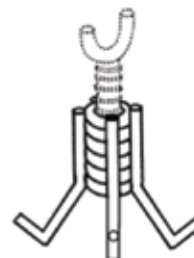


CODE	SIZE	WEIGHT	PACKAGED
PSH121	1/2" X 1-1/2"	11.0/C	100/BOX
PSH123	1/2" X 3"	17.5/C	100/BOX
PSH124	1/2" X 4"	22.4/C	100/BOX
PSH126	1/2" X 6"	30.5/C	100/BOX
ADD ON PER INCH		4.5/C	
PSH343	3/4" X 3"	36.9/C	100/BOX
PSH344	3/4" X 4"	46.4/C	100/BOX
PSH346	3/4" X 6"	64.9/C	100/BOX
ADD ON PER INCH		9.0/C	

SPECIAL SIZES AVAILABLE UPON REQUEST

SCREED CHAIR BASES

- COIL THREAD



CODE	SIZE	WEIGHT	PACKAGED
SCB122	1/2" X 2-1/2"	26.5/C	100/BOX
SCB123	1/2" X 3-1/2"	27.2/C	100/BOX
SCB125	1/2" X 5-1/2"	30.7/C	100/BOX
SCB342	3/4" X 2-1/2"	35.2/C	100/BOX
SCB343	3/4" X 3-1/2"	40.9/C	100/BOX
SCB345	3/4" X 5-1/2"	53.5/C	100/BOX

SPECIAL SIZES AVAILABLE UPON REQUEST

SCREED HOLDERS, HEAVY DUTY

- ONE COIL NUT INCLUDED
- UP TO 2-3/8" OD



CODE	SIZE	WEIGHT	PACKAGED
HDS344	3/4" X 4-1/4"	130.5/C	EACH
HDS346	3/4" X 6-3/4"	196.0/C	EACH
HDS349	3/4" X 9-3/4"	227.9/C	EACH
HDS104	1" X 4-1/4"	170.0/C	EACH
HDS106	1" X 6-3/4"	246.0/C	EACH
HDS109	1" X 9-3/4"	300.0/C	EACH

SPECIAL SIZES AVAILABLE UPON REQUEST**SCREED CHAIR BASES, HEAVY DUTY**

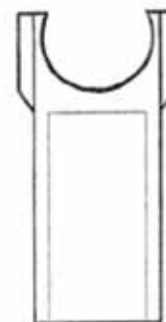
- FOR USE WITH 1" SCREED HOLDERS



CODE	SIZE	WEIGHT	PACKAGED
SCHD03	1" X 3-1/2"	120.0/C	EACH
SCHD05	1" X 5-1/2"	125.0/C	EACH
SCHD08	1" X 8-1/2"	171.0/C	EACH

PLASTIC REBAR SADDLES

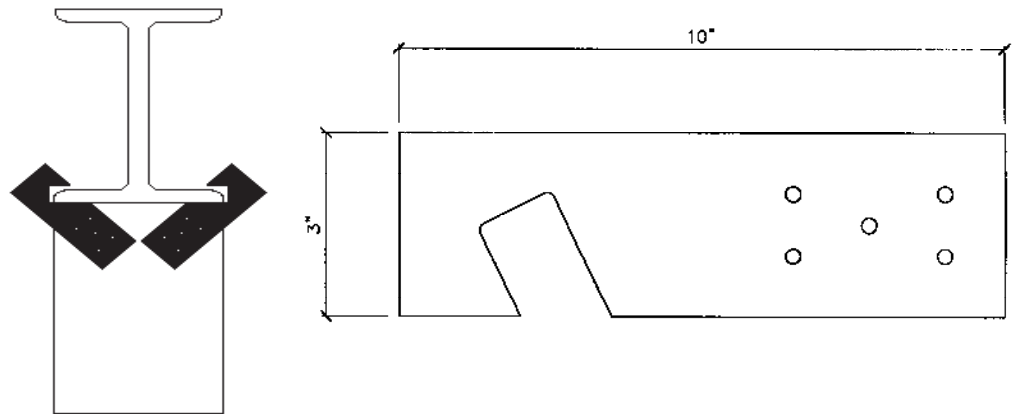
- FITS OVER #4 VERTICAL REBAR.
- ACCOMMODATES UP TO #4 HORIZONTAL REBAR.



CODE	TYPE	WEIGHT	PACKAGED
REBSAD	#4 BAR	.90/C	3000/BOX

FALSEWORK ACCESSORIES

BEAM CLIPS



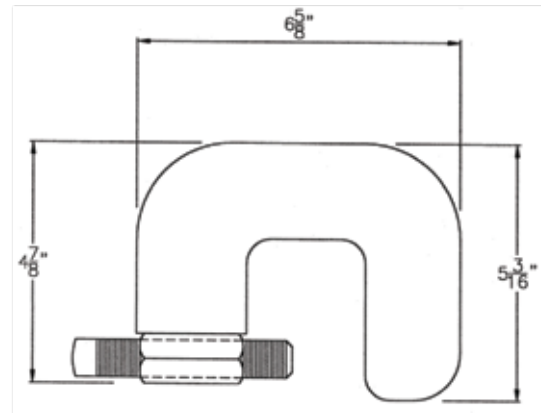
THIS PRODUCT REQUIRES PROPER ENGINEERING

CODE	WEIGHT	PACKAGED
BEAMCLP	1.5/EA	EACH

C-CLAMPS, HEAVY DUTY

- AVAILABLE WITH THE FOLLOWING OPENINGS:

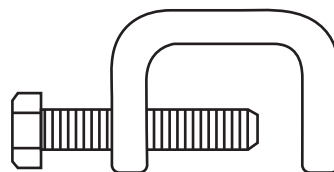
2-7/16"
3-1/2"
5"
SPECIAL SIZING AVAILABLE



CODE	WEIGHT	PACKAGED
CCLAMP	5.5/EA	EACH

THIS PRODUCT REQUIRES PROPER ENGINEERING

2" C-CLAMPS



CODE	WEIGHT	PACKAGED
CLAMP2	1.0/EA	EACH

THIS PRODUCT REQUIRES PROPER ENGINEERING

CUSTOM STEEL FABRICATIONS



STEEL STRONGBACKS



WALL PANEL SCAFFOLD BRACKETS



HAND RAIL POSTS



CAPITAL ENTRY FORMS



LACKEY BRACKETS



HAUNCH BRACKETS

CUSTOM STEEL FABRICATIONS



SKIP BOXES/MATERIAL BINS



PRE-STRESS BRACE PLATES



DECK BOLTS



SWING LOCKS



EDGE OF DECK BRACKETS



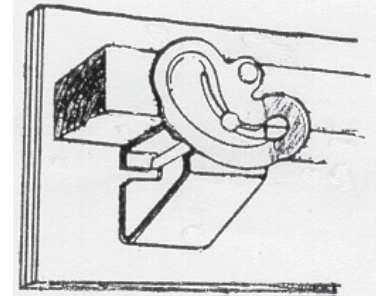
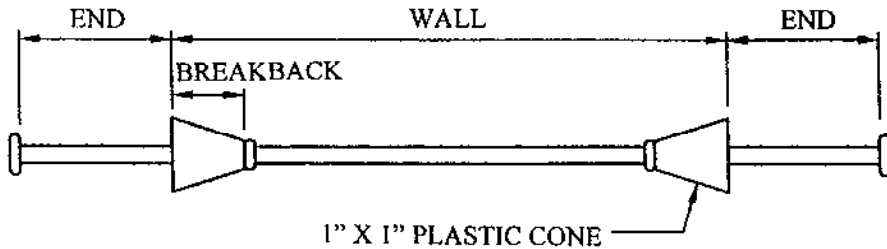
EDGE OF DECK FORMS



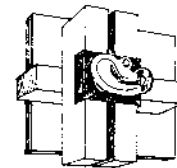
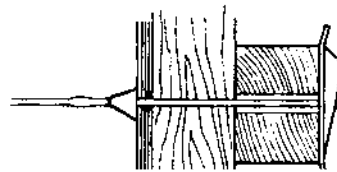
BEAM ENDS

STANDARD STOCK SNAPTIES, 2,250 LBS. APPROX. SWL, 2:1 SF

- 1" X 1" CONES
- LOOSE CUPPED WASHER

**SHORT END 4-3/4"**

CODE	WALL	WEIGHT	PACKAGED
STSE06	6"	24.0/C	100/BOX
STSE08	8"	25.8/C	100/BOX
STSE10	10"	28.0/C	100/BOX
STSE12	12"	30.3/C	100/BOX
STSE14	14"	32.6/C	100/BOX
STSE16	16"	34.8/C	100/BOX
STSE18	18"	37.1/C	100/BOX
STSE20	20"	39.4/C	100/BOX
STSE24	24"	43.9/C	100/BOX
STSE30	30"	50.6/C	100/BOX

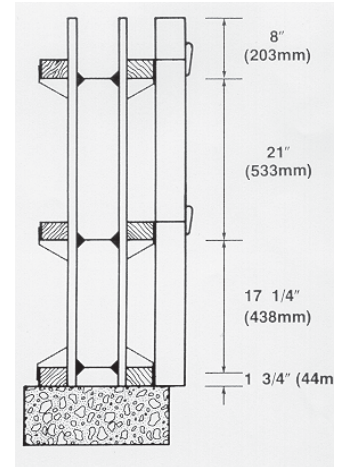
**LONG END 8-1/4"**

CODE	WALL	WEIGHT	PACKAGED
STLE06	6"	31.8/C	100/BOX
STLE08	8"	34.0/C	100/BOX
STLE10	10"	36.3/C	100/BOX
STLE12	12"	38.5/C	100/BOX
STLE14	14"	40.8/C	100/BOX
STLE16	16"	43.0/C	100/BOX
STLE18	18"	45.3/C	100/BOX
STLE20	20"	47.6/C	100/BOX
STLE24	24"	52.1/C	100/BOX
STLE30	30"	58.9/C	100/BOX

THIS PRODUCT REQUIRES PROPER ENGINEERING

SNAPTIE SPACING FOR CONVENTIONAL FORMING

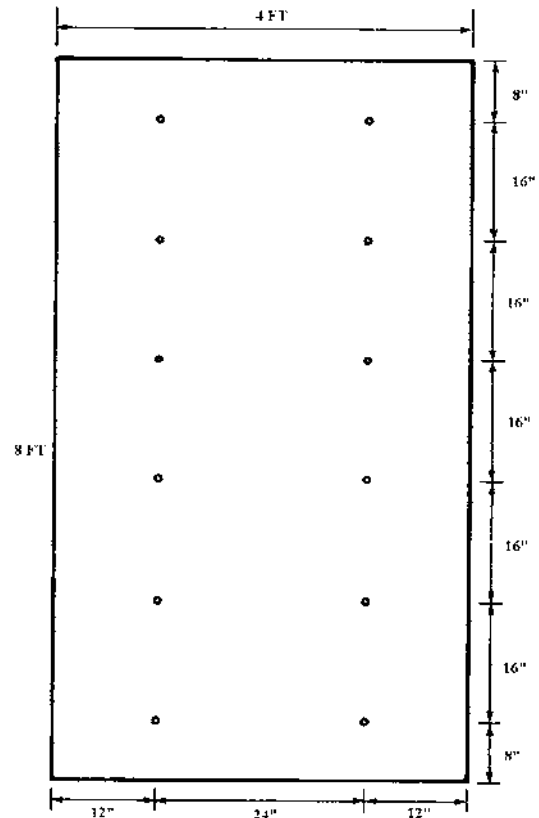
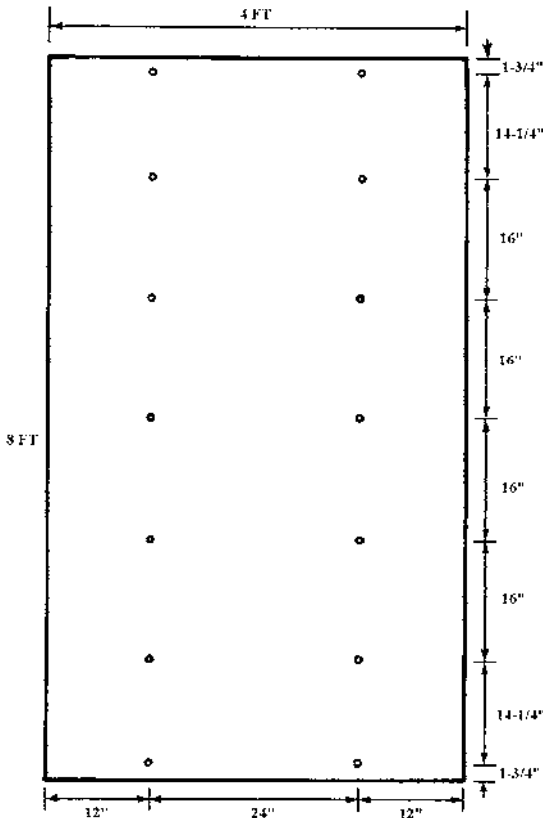
4FT Wall Form



SUGGESTED SPACING DIAGRAMS

For Single Water System
Use 9/16" drill bit.

Diagram based on: Pour Rate = 4 ft./hour
Concrete temperature: 70°F
Plywood: 3/4" thickness, face grain perpendicular to walers
Standard 16" waler spacing
For L/360 deflection use 12" waler spacing



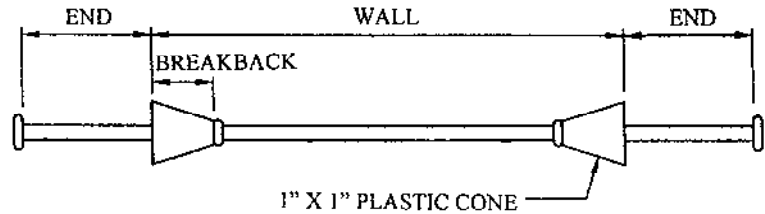
1. Use this diagram if the top waler is used for starting another tier of panels. This spacing should also be used where the panels will be attached to the 2 x 4 starter plate with inverted brackets.
2. Drilling pattern to minimize the number of ties required. A 2 x 4 starter plate is not required with this pattern.

The limiting factor in the spacing diagrams recommended here is plywood deflection. Neither 2 X 4 walers nor 3M ties are stressed to their allowable working loads. To do so would result in deflection which is generally unacceptable. Tie load with 4 ft./hour pour rate at 70° F using 16" waler spacing is estimated at 1800 lbs.

Where architectural finish is important, decrease waler spacing or reduce pour rate.

STANDARD (NON-STOCK) SNAPTIES ***2,250 LBS. APPROX. SWL, 2:1 SAFETY FACTOR***

- 1" X 1" CONES
- LOOSE CUPPED WASHER
- SPECIAL ORDER



SHORT END 4-3/4"

CODE	WALL	WEIGHT	PACKAGED
SNPTIE	UNDER 6"	24.7/C	100/BOX
SNPTIE	6" TO 8"	24.7/C	100/BOX
SNPTIE	8" TO 10"	26.9/C	100/BOX
SNPTIE	10" TO 12"	29.1/C	100/BOX
SNPTIE	12" TO 14"	31.3/C	100/BOX
SNPTIE	14" TO 16"	33.5/C	100/BOX
SNPTIE	16" TO 18"	35.7/C	100/BOX
SNPTIE	18" TO 20"	38.0/C	100/BOX
SNPTIE	20" TO 22"	40.2/C	100/BOX
SNPTIE	22" TO 24"	42.5/C	100/BOX
ADD ON PER INCH	UP TO 48"	1.1/C	

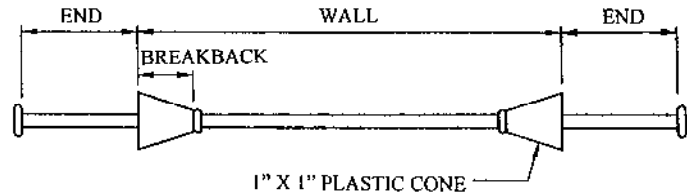
LONG END 8-1/4"

CODE	WALL	WEIGHT	PACKAGED
SNPTIE	UNDER 6"	34.0/C	100/BOX
SNPTIE	6" TO 8"	34.0/C	100/BOX
SNPTIE	8" TO 10"	36.3/C	100/BOX
SNPTIE	10" TO 12"	38.5/C	100/BOX
SNPTIE	12" TO 14"	40.1/C	100/BOX
SNPTIE	14" TO 16"	42.3/C	100/BOX
SNPTIE	16" TO 18"	44.5/C	100/BOX
SNPTIE	18" TO 20"	47.7/C	100/BOX
SNPTIE	20" TO 22"	49.9/C	100/BOX
SNPTIE	22" TO 24"	52.1/C	100/BOX
ADD ON PER INCH	UP TO 48"	1.1/C	

THIS PRODUCT REQUIRES PROPER ENGINEERING

HIGH STRENGTH SNAPTIES ***3,250 APPROX. SWL, 2:1 SAFETY FACTOR***

- 1" X 1" CONES
- LOOSE CUPPED WASHER



SHORT END 4-3/4"

CODE	WALL	WEIGHT	PACKAGED
STSE04HS	UNDER 6"	25.0/C	100/BOX
STSE06HS	6"	25.5/C	100/BOX
STSE08HS	8"	26.2/C	100/BOX
STSE10HS	10"	28.4/C	100/BOX
STSE12HS	12"	30.6/C	100/BOX
STSE14HS	14"	32.8/C	100/BOX
STSE16HS	16"	35.0/C	100/BOX
STSE18HS	18"	37.2/C	100/BOX
STSE20HS	20"	39.4/C	100/BOX
STSE22HS	22"	41.6/C	100/BOX
STSE24HS	24"	43.8/C	100/BOX
ADD ON PER INCH	UP TO 48"	1.1/C	

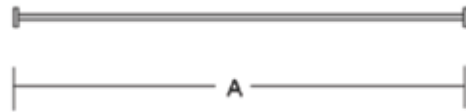
LONG END 8-1/4"

CODE	WALL	WEIGHT	PACKAGED
STLE04HS	UNDER 6"	34.0/C	100/BOX
STLE06HS	6"	34.0/C	100/BOX
STLE08HS	8"	35.0/C	100/BOX
STLE10HS	10"	37.2/C	100/BOX
STLE12HS	12"	39.4/C	100/BOX
STLE14HS	14"	41.6/C	100/BOX
STLE16HS	16"	43.8/C	100/BOX
STLE18HS	18"	46.0/C	100/BOX
STLE20HS	20"	48.2/C	100/BOX
STLE22HS	22"	50.4/C	100/BOX
STLE24HS	24"	52.6/C	100/BOX
ADD ON PER INCH	UP TO 48"	1.1/C	

THIS PRODUCT REQUIRES PROPER ENGINEERING

TIP TO TIP SNAPTIES, 2,250 LBS. APPROX. SWL, 2:1 SAFETY FACTOR

LENGTH	WEIGHT
UP TO 30" OVERALL	36.8/C
EACH 1" ADD:	1.1/C

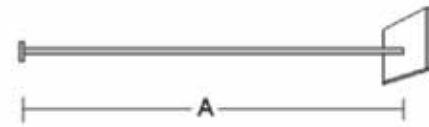


WATERSEAL SNAPTIES, 2,250 LBS. APPROX. SWL, 2:1 SAFETY FACTOR

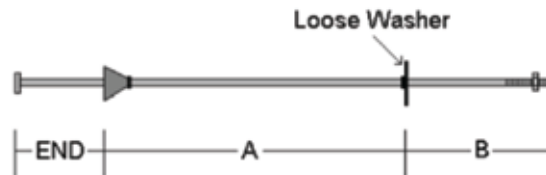


PLATE TIES, 2,250 LBS. APPROX. SWL, 2:1 SAFETY FACTOR

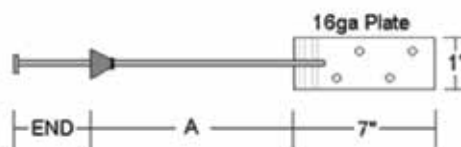
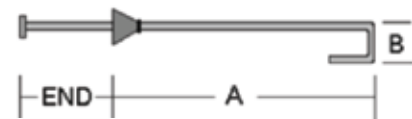
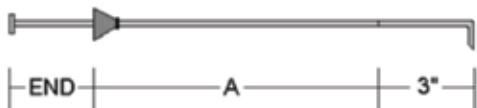
LENGTH	WEIGHT
UP TO 30" OVERALL	41.3/C
EACH 1" ADD:	1.1/C



**THREADED SNAPTIES (REMOVEABLE) 1,875 LBS. SWL, 2:1
1,875 LBS. APPROX. SWL, 2:1 SAFETY FACTOR**



**SPANDREL POINT / HOOK / PLATE SNAPTIES, 250 LBS. SWL
250 LBS. APPROX. SWL, 2:1 SAFETY FACTOR**



WEDGE FORM TIE

- DESIGNED FOR LOW FOUNDATION WALL FORMS
- MADE FROM 18g GALVANIZED STEEL
- WEDGES NOT INCLUDED



CODE	SIZE	WEIGHT
WGFT06	6"	8.25/C
WGFT08	8"	11.00/C
WGFT10	10"	13.75/C
WGFT12	12"	16.50/C
WGFT14	14"	19.25/C
WGFT16	16"	22.00/C
WGFT18	18"	24.75/C
WGFT20	20"	27.50/C
WGFT24	24"	33.00/C

WEDGE FORM TIE WEDGE

CODE	WEIGHT	PACKAGED
WGFTWG	0.032 LBS./EA	200 PER BOX

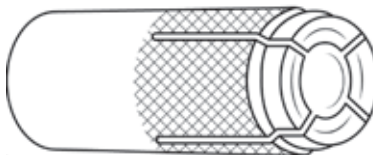
***FOOTING TIES***

- DESIGNED FOR USE ON TOP OF FOOTING FORMS.
- ECONOMICAL WAY TO SUPPORT FORMS WHILE POURING CONCRETE
- MADE FROM HIGH-STRENGTH GALVANIZED STEEL



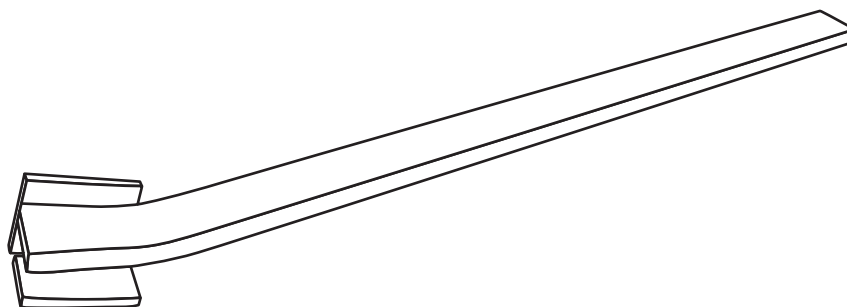
CODE	SIZE	WEIGHT
FOOT06	6"	13.0/C
FOOT08	8"	17.0/C
FOOT10	10"	20.0/C
FOOT12	12"	24.0/C
FOOT14	14"	27.0/C
FOOT16	16"	30.0/C
FOOT18	18"	33.0/C
FOOT20	20"	36.0/C
FOOT24	24"	43.0/C
FOOT30	30"	50.0/C
FOOT36	36"	63.0/C
FOOT48	48"	80.0/C

DROP-IN COIL ANCHORS



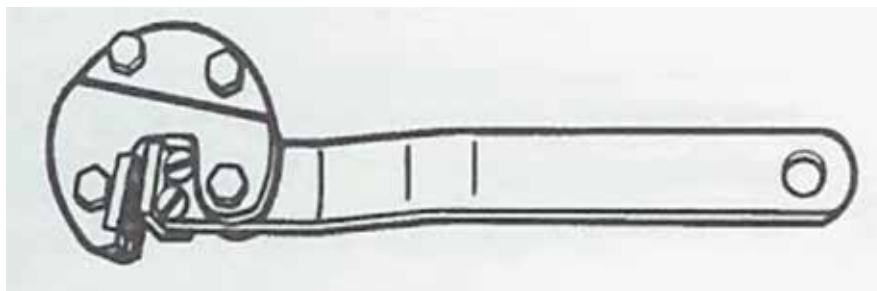
CODE	SIZE	WEIGHT	PACKAGED
DROPIN12	1/2"	4 LB/BOX	50
DROPIN34	3/4"	4 LB/BOX	10

SNAPTIE WRENCH



CODE	WEIGHT	PACKAGED
STWREN	2.3/EA	EACH

SNAPTIE WRENCH, JAW TYPE



CODE	WEIGHT	PACKAGED
STBBWR	1.5/EA	EACH

BASE TIES, 1,500 LBS. SWL, 2:1 SAFETY FACTOR



CODE	WALL	WEIGHT	PACKAGED
BT06	6"	17.0/C	100/BOX
BT08	8"	19.0/C	100/BOX
BT10	10"	23.0/C	100/BOX
BT12	12"	25.0/C	100/BOX

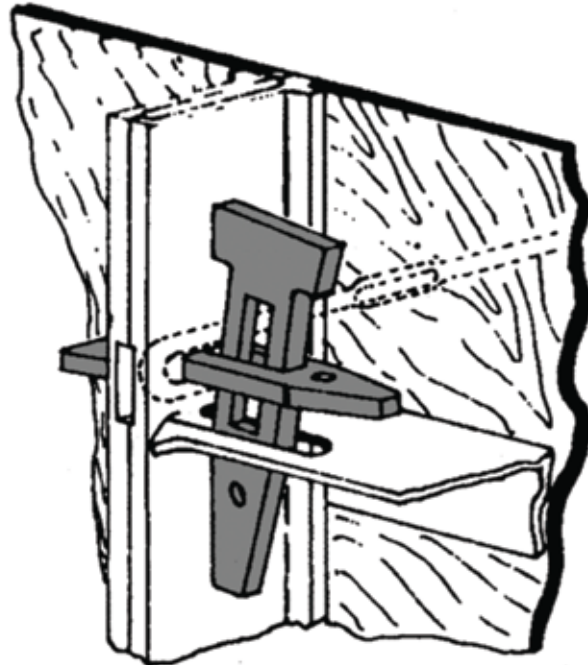
EACH 1" OVER 12", ADD \$65.00/C

WEDGE BOLTS

- FOR MODULAR FORM CONNECTIONS

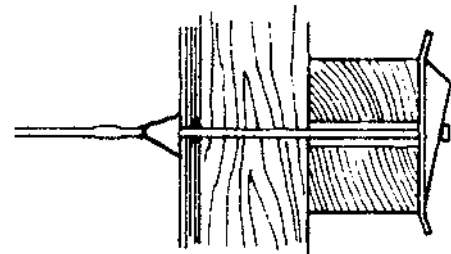


STANDARD BOLT



LONG BOLT

TYPE	CODE	WEIGHT	PACKAGED
STANDARD	WEGBLT	12.0/C	500/CTN
LONG BOLT	WGBTL	15.0/C	400/CTN

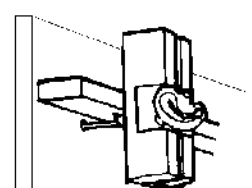
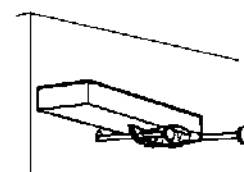
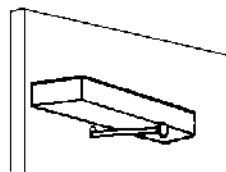
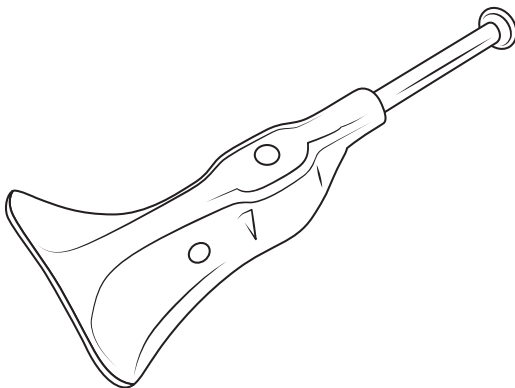
HEAVY DUTY SNAPTIE WEDGES

CODE	APPROX SWL 2:1	WEIGHT	PACKAGED
WEDGHS	3,350 LBS	47.0/C	100/BOX

THIS PRODUCT REQUIRES PROPER ENGINEERING

SNAPTIE EXTENDERS

Snaptie extenders easily convert a 4-3/4" end snaptie to an 8-1/4" end, for quick application of strongbacks.

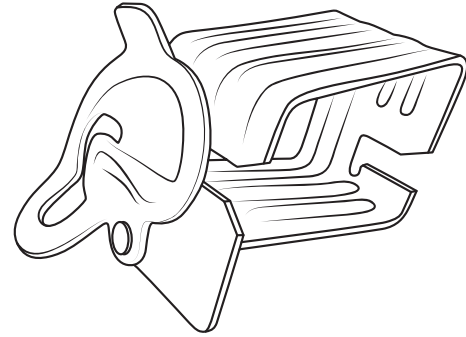
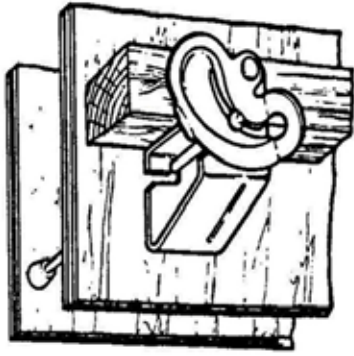


CODE	APPROX SWL 2:1	WEIGHT	PACKAGED
TIEEXT	2,250 LBS	20.0/C	100/BOX

THIS PRODUCT REQUIRES PROPER ENGINEERING

SINGLE LINER BRACKETS, A-BRACKET

The Single Liner Bracket can be used on all types of wall forms, when using snapties and single walers.

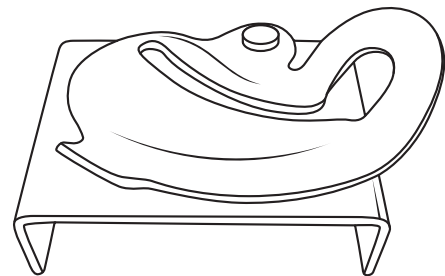
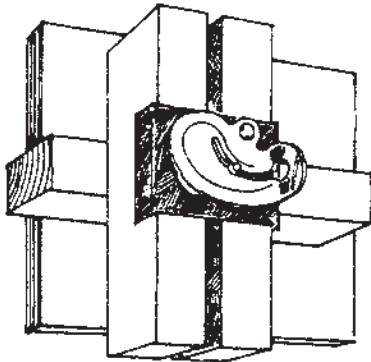


CODE	APPROX SWL 2:1	WEIGHT	PACKAGED
ABKT	2,250 LBS	1.4/EA	50/BOX

THIS PRODUCT REQUIRES PROPER ENGINEERING

STRONGBACK BRACKETS, C-BRACKET

The Strongback Bracket, is used for double waler and strongback applications.

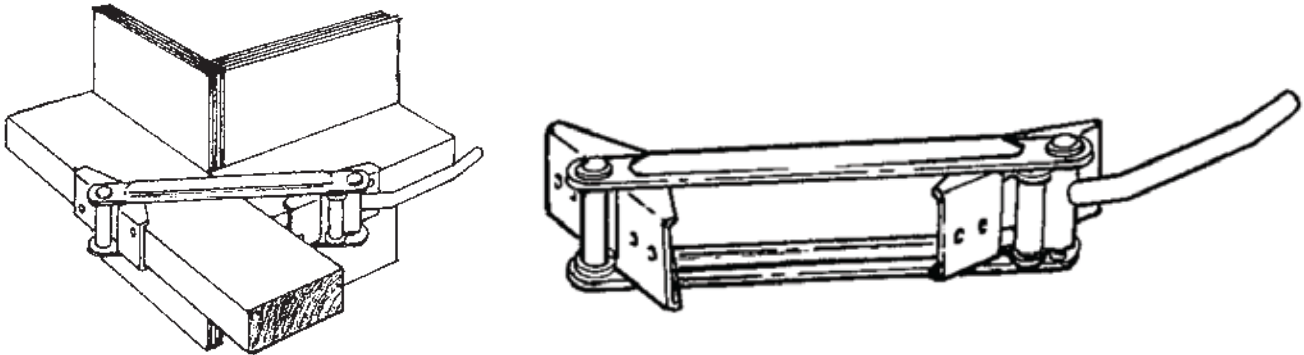


CODE	APPROX SWL 2:1	WEIGHT	PACKAGED
CBKT	2,250 LBS	1.1/EA	60/BOX

THIS PRODUCT REQUIRES PROPER ENGINEERING

CORNER LOCK BRACKETS

- SAVES TIME IN FORMING WALL CORNERS.

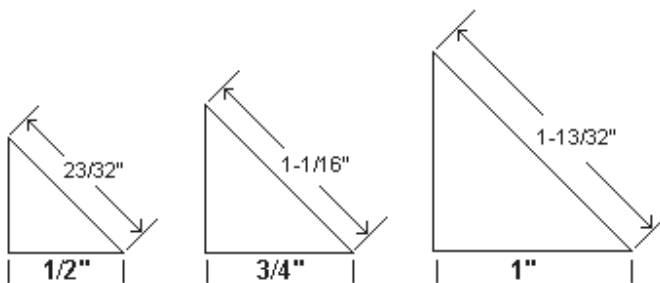
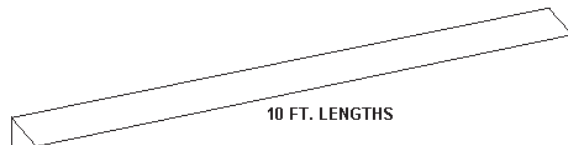


CODE	WEIGHT	PACKAGED
CRNLCK	2.0/EA	20/BOX

THIS PRODUCT REQUIRES PROPER ENGINEERING

STEEL CHAMFER STRIP

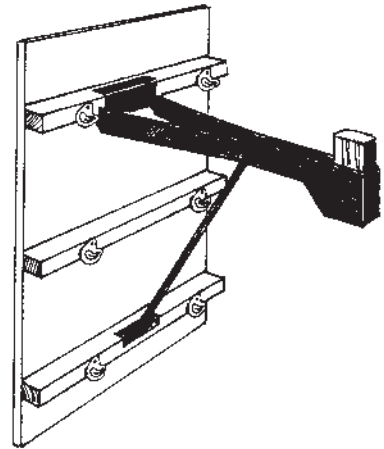
- FOR STEEL FORMING
- AVAILABLE IN 10' LENGTHS



SIZE	CODE	WEIGHT	PACKAGED
1/2"	CHAM12	.44/FT	EACH 10' PC
3/4"	CHAM34	1.12/FT	EACH 10' PC
1"	CHAM10	1.75/FT	EACH 10' PC

SINGLE LINER SCAFFOLD JACKS

This Scaffold Jack provides the framework for 2x10 planks, to make a convenient working platform. Scaffold Jack attaches to two A brackets. The built-in guard rail receptacle makes it easy to install a safe and economical safety rail. Space at 8'-0" max centers.

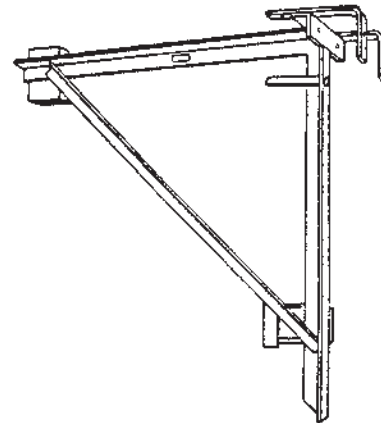


CODE	WEIGHT	PACKAGED
DONJCK	17.0/EA	EACH
THIS PRODUCT REQUIRES PROPER ENGINEERING		

DELUXE SCAFFOLD BRACKETS

The Deluxe Scaffold Bracket hooks over 2x4 or 2x6 walers, to provide safe, solid scaffolding on wall forms. Waler hooks are removable for flush wall mount applications as well.

- Max bracket spacing should be limited to 8' on center.
- **900LB. APPROXIMATE S.W.L**

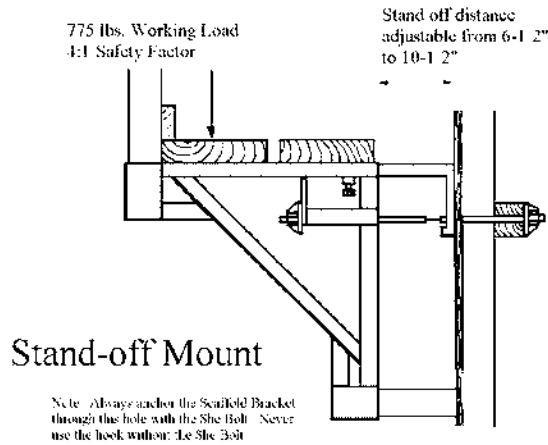
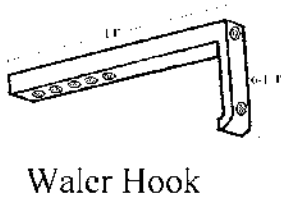
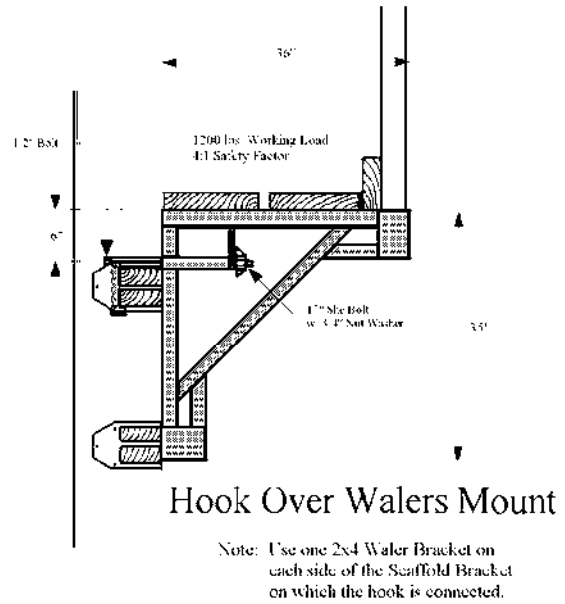
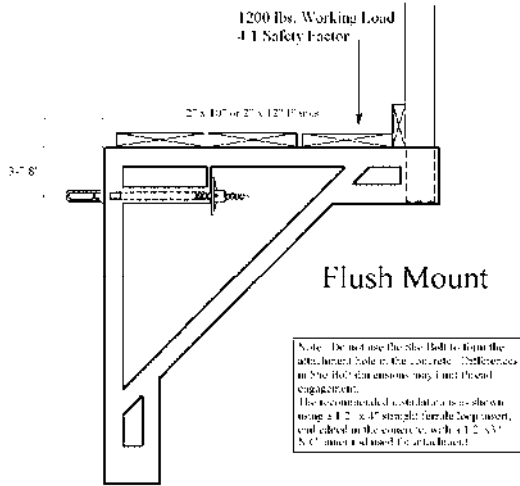


CODE	WEIGHT	PACKAGED
DSCFJCK	28.0/EA	EACH
THIS PRODUCT REQUIRES PROPER ENGINEERING		

SCAFFOLD BRACKETS w/ WALER HOOK

The Spectrum Scaffold Bracket w/Waler Hook provides the framework for 2"x10" or 2"x12" planks, to make a convenient working platform. The built-in guard rail receptacle makes it easy to install a safe and economical safety rail.

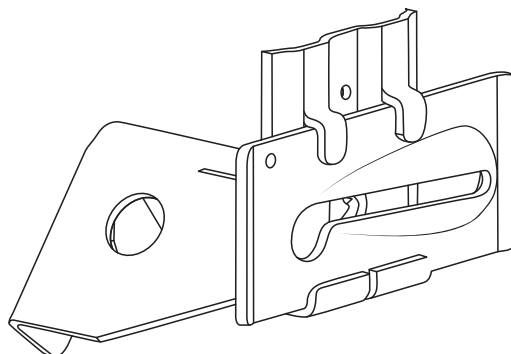
APPLICATION: Space at 8'-0" max. centers. It can be installed over horizontal walers as well as a flush mount application with Spectrum She Bolts.



CODE	WEIGHT	PACKAGED
SCFBKT	28.0/EA	EACH

SNAP BRACKETS

The Snap Bracket can be used on all types of poured in place forms, when using snapties and single walers.

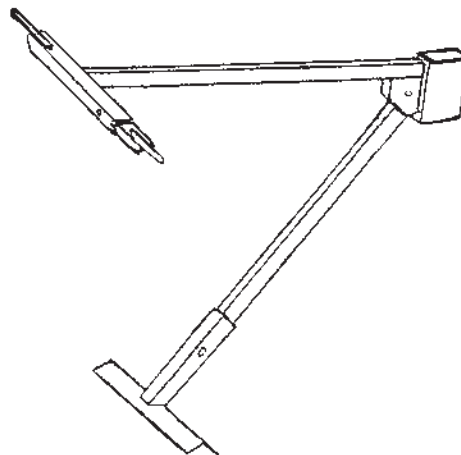


CODE	APPROX SWL 2:1	WEIGHT	PACKAGED
SNPBKT	2,250 LBS.	1.4/EA	50/BOX

THIS PRODUCT REQUIRES PROPER ENGINEERING

SNAP JACKS

The Snap Jack provides the framework for 2x10 planks, to make a convenient working platform. The built-in guard rail receptacle makes it easy to install a safe and economical safety rail, spaced at 8 ft. max. centers.



CODE	WEIGHT	PACKAGED
SNPJCK	17.0/EA	EACH

THIS PRODUCT REQUIRES PROPER ENGINEERING

LINER CLAMPS

Liner Clamps are specifically designed for use as a single 2x4 strongback clamp.

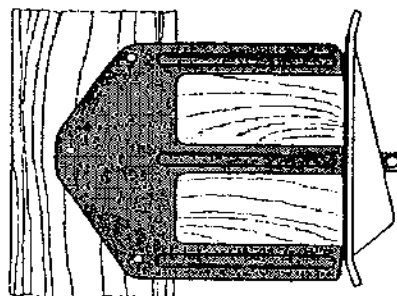
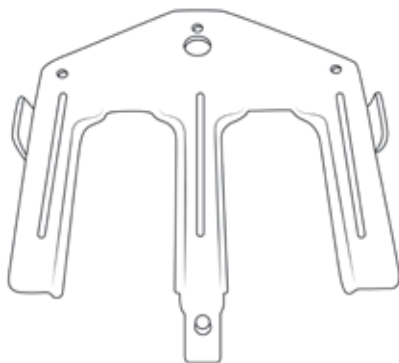


CODE	WEIGHT	PACKAGED
LNRCLM	1.3/EA	25/BOX

THIS PRODUCT REQUIRES PROPER ENGINEERING

DOUBLE WALER BRACKETS

Designed for double 2x4 or 2x6 strongbacks, used with a heavy-duty Snaptie Wedge.



CODE	SIZE	WEIGHT	PACKAGED
WLBR24	2X4	.88/EA	25/BOX
WLBR26	2X6	1.0/EA	25/BOX

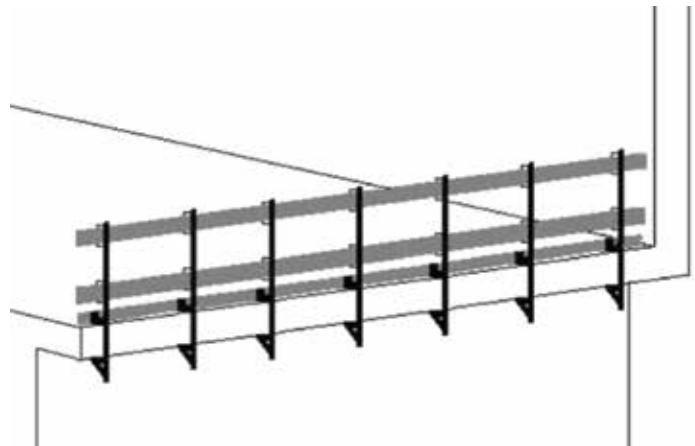
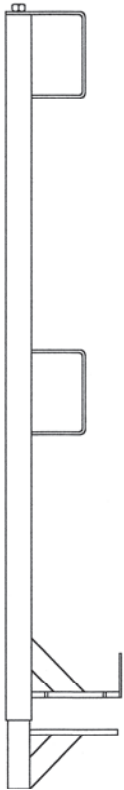
THIS PRODUCT REQUIRES PROPER ENGINEERING

GUARD RAIL POSTS, SLAB GRABBERS

The Spectrum Guard Rail Post is a versatile and durable clamp-on post, for use on open-sided floors, decks, and platforms of thickness' from 3" to 36". The many features include a square telescoping tube, providing a uniform top rail height of 42", closed loops for 2x4 or 2x6 wood rails, and fast threading 3/4" coil rod for easy adjustment.

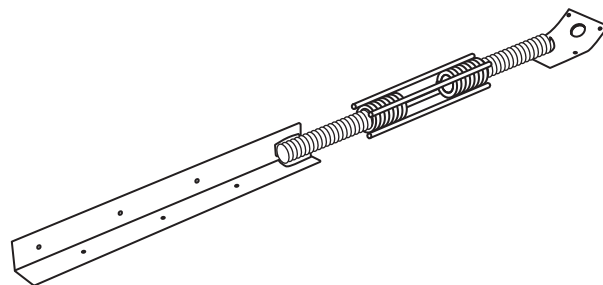
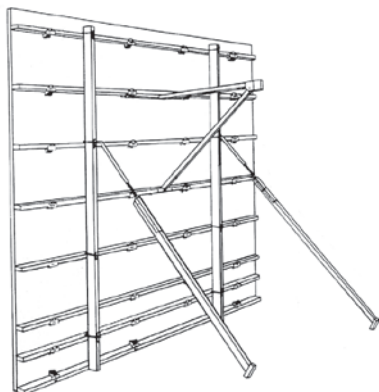
MEETS OSHA REQUIREMENTS

- **CUSTOM GUARD RAIL POST AND HAND RAIL POSTS AVAILABLE UPON REQUEST**



CODE	WEIGHT	PACKAGED
GRDPST	23.0/EA	EACH

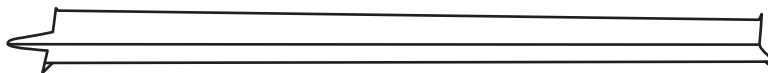
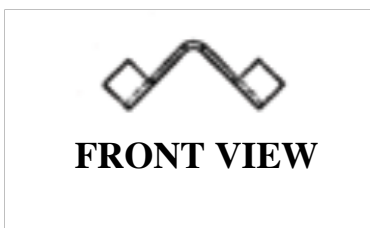
FORM ALIGNER BRACES, TURNBUCKLES



CODE	TYPE	WEIGHT	PACKAGED
FAB100	STANDARD	8.5/EA	EACH

WALL SPREADERS

- PROVIDES INTERNAL FORM SPREADING
- SPECIAL SIZES AVAILABLE UPON REQUEST



CODE	SIZE	WEIGHT	PACKAGED
WLSP06	6" WALL	6.2/C	500/BOX
WLSP08	8" WALL	8.2/C	500/BOX
WLSP10	10" WALL	10.2/C	500/BOX
WLSP12	12" WALL	12.2/C	500/BOX

HEAVY DUTY HANDSET 'S' LOOP TIES 3,000 LBS. APPROX. SWL, 2:1 SAFETY FACTOR

- DESIGNED FOR USE WITH MODULAR TYPE PANEL FORM SYSTEMS.
- 2-1/8" ENDS.

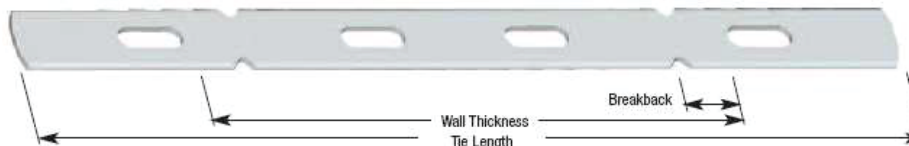


CODE	WALL	WEIGHT	PACKAGED
HDLP06	6"	21.0/C	100/BOX
HDLP08	8"	23.0/C	100/BOX
HDLP10	10"	25.0/C	100/BOX
HDLP12	12"	28.0/C	100/BOX
HDLP14	14"	31.0/C	100/BOX
HDLP16	16"	34.0/C	100/BOX
HDLP18	18"	36.0/C	100/BOX
HDLP20	20"	39.0/C	100/BOX
HDLP24	24"	45.0/C	100/BOX
HDLP30	30"	53.0/C	50/BUNDLE
HDLP36	36"	61.0/C	50/BUNDLE

THIS PRODUCT REQUIRES PROPER ENGINEERING.

STANDARD 'X' FLAT TIES, 3,000 LBS. APPROX. SWL, 2:1 SF

- DESIGNED FOR USE WITH MODULAR TYPE PANEL FORM SYSTEMS WHEN GANG IS SET IN PLACE.

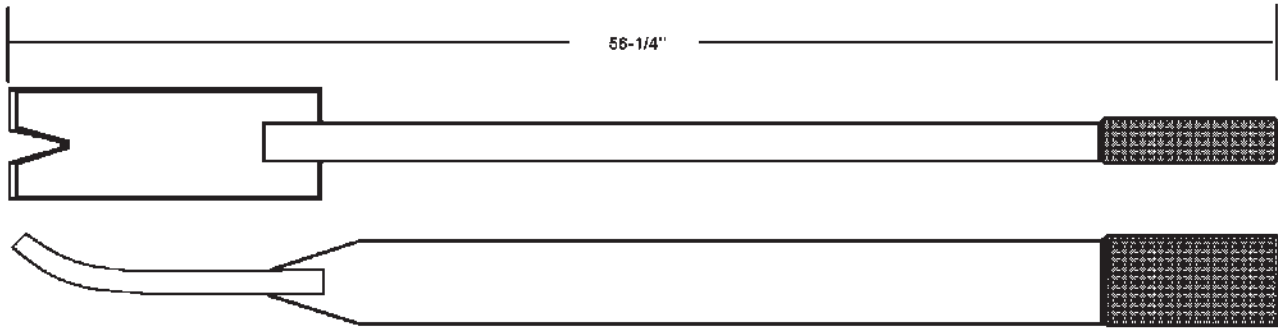


CODE	WALL	WEIGHT	PACKAGED
XFLT06	6"	27.0/C	100/BOX
XFLT08	8"	31.0/C	100/BOX
XFLT10	10"	36.0/C	100/BOX
XFLT12	12"	42.0/C	100/BOX
XFLT14	14"	48.0/C	100/BOX
XFLT16	16"	53.0/C	100/BOX
XFLT18	18"	58.0/C	100/BOX
XFLT20	20"	63.0/C	100/BOX
XFLT24	24"	72.0/C	100/BOX
XFLT30	30"	86.0/C	50/BUNDLE
XFLT36	36"	101.0/C	50/BUNDLE

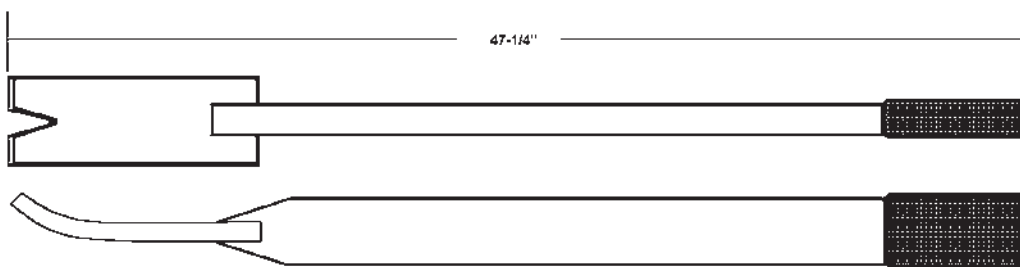
THIS PRODUCT REQUIRES PROPER ENGINEERING

PRO BARS, STRIPPING BARS

- POWDER COATED FINISH
- SOFT GRIP INCLUDED
- 3" BLADE



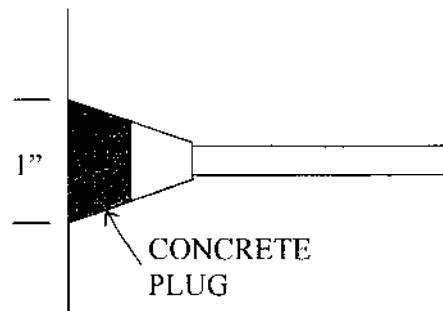
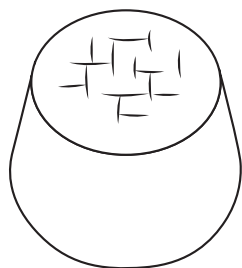
PRO BAR



PRO BAR JUNIOR

TYPE	CODE	WEIGHT	PACKAGED
PRO BAR	PROBRY	15.0/EA	EACH
PRO BAR JR.	PROJRO	7.0/EA	EACH

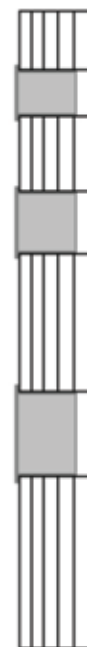
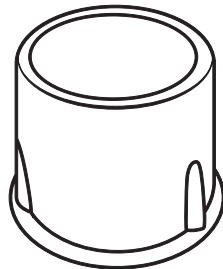
CONCRETE SNAPTIE PLUGS



CODE	SIZE	WEIGHT	PACKAGED
CONPLG	FOR 1" X 1" CONE	2.4/C	500/BOX

PLASTIC PLUGS

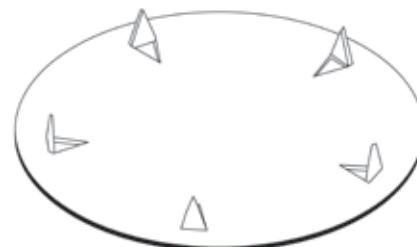
- FOR PLUGGING UNWANTED HOLES IN PLYWOOD FORMS
- TIGHT FITTING FOR EASY INSTALLATION



CODE	SIZE	WEIGHT	PACKAGED
PLG916	9/16"	12.0/BAG	5000/BAG
PLG1316	13/16"	10.0/BAG	2500/BAG

METAL FORM PATCHES

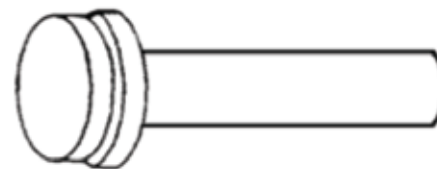
- FOR COVERING ALL KINDS OF HOLES AND DEFECTS IN PLYWOOD FORM LUMBER.
- SHARP SPIKES EASILY NAIL INTO PLYWOOD.



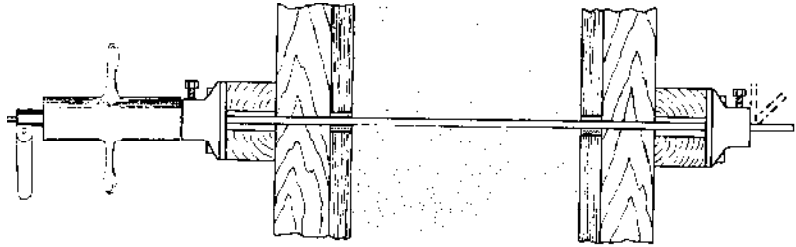
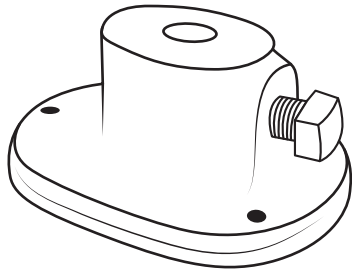
CODE	SIZE	WEIGHT	PACKAGED
MET134	1-3/4"	38.0/BOX	1000/BOX
MET214	2-1/4"	40.5/BOX	1000/BOX
MET234	2-3/4"	33.0/BOX	1000/BOX

MAGNETIC SETTING TOOL

- FOR APPLICATION OF METAL FORM PATCHES



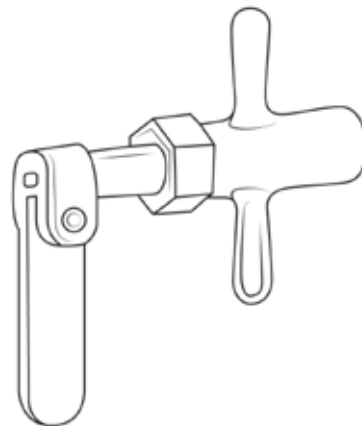
CODE	WEIGHT	PACKAGED
METTOOL	1.0/EA	EACH

ROD CLAMPS

CODE	SIZE	WEIGHT	2:1 SWL*	PACKAGED
ROD014	1/4"	38.2/C	1,125 LBS.	100/BOX
ROD038	3/8"	71.0/C	2,250 LBS.	50/BOX

THIS PRODUCT REQUIRES PROPER ENGINEERING

***SAFE WORKING LOAD IS APPROXIMATE**

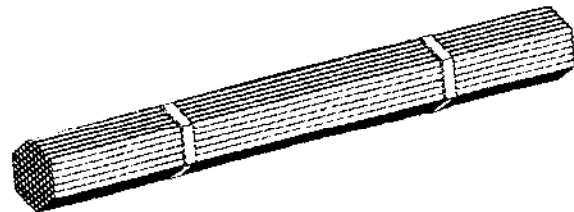
ROD TIGHTENING WRENCHES

CODE	SIZE	WEIGHT
WRCH14	1/4"	1.3/EA
WRCH38	3/8"	1.3/EA

THIS PRODUCT REQUIRES PROPER ENGINEERING

PENCIL ROD

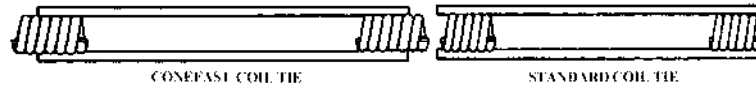
- AVAILABLE IN LENGTHS OR IN COILS



PRICING AVAILABLE UPON REQUEST

COIL TIES, 2 STRUT

- APPROXIMATE SAFE WORKING LOAD IS 2:1

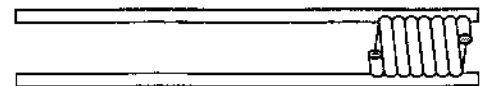


	1/2" DIA. 4.5M	1/2" DIA. 6.75M	3/4" DIA. 6.75M	3/4" DIA. 9M	1" DIA. 13.5M
WALL	WT./C	WT./C	WT./C	WT./C	WT./C
6" TO 8"	32.0	51.0	69.0	91.0	155.0
8" TO 9"	34.0	55.0	73.0	97.0	164.0
9" TO 10"	36.0	59.0	77.0	103.0	173.0
10" TO 11"	39.0	63.0	81.0	110.0	182.0
11" TO 12"	42.0	67.0	85.0	116.0	191.0
12" TO 13"	44.0	71.0	89.0	122.0	200.0
13" TO 14"	47.0	75.0	93.0	128.0	209.0
14" TO 15"	49.0	80.0	98.0	135.0	218.0
15" TO 16"	51.0	84.0	102.0	141.0	227.0
16" TO 17"	54.0	88.0	106.0	147.0	236.0
17" TO 18"	56.0	92.0	110.0	153.0	245.0
18" TO 19"	58.0	96.0	114.0	160.0	254.0
19" TO 20"	60.0	100.0	118.0	166.0	263.0
20" TO 21"	63.0	105.0	123.0	172.0	272.0
21" TO 22"	65.0	109.0	127.0	178.0	281.0
22" TO 23"	67.0	113.0	131.0	185.0	290.0
23" TO 24"	70.0	117.0	135.0	191.0	299.0
EA. INCH ADD	2.3	4.2	4.2	5.3	8.4
CONE FAST ADD	2.0	2.0	7.0	7.0	20.0
WATERSEAL ADD	16.0	16.0	32.0	32.0	32.0

THIS PRODUCT REQUIRES PROPER ENGINEERING

WELDING COIL TIES

- APPROX. SAFE WORKING LOAD IS 2:1



1/2" x 4" 4.5M	1/2" x 4" 6.75M	3/4" x 6" 6.75M	3/4" x 6" 9M	1" x 8" 13.5M
-----------------------	------------------------	------------------------	---------------------	----------------------

THIS PRODUCT REQUIRES PROPER ENGINEERING

COIL TIES, 4 STRUT

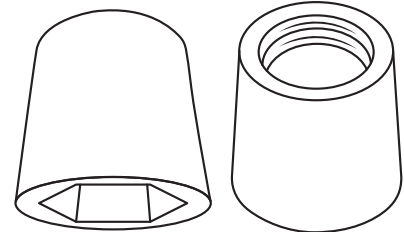
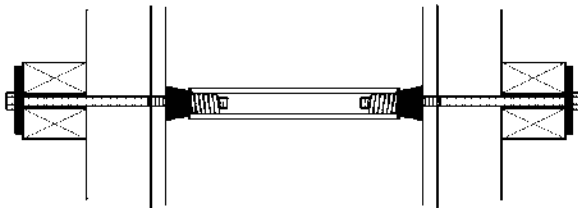
- APPEOX. SAFE WORKING LOAD IS 2:1



	1" DIA. 18M	1-1/4" DIA. 27M
WALL	WT./C	WT./C
6" TO 8"	185.0	246.0
8" TO 9"	198.0	264.0
9" TO 10"	210.0	282.0
10" TO 11"	223.0	299.0
11" TO 12"	235.0	317.0
12" TO 13"	248.0	335.0
13" TO 14"	260.0	351.0
14" TO 15"	273.0	369.0
15" TO 16"	285.0	386.0
16" TO 17"	298.0	404.0
17" TO 18"	310.0	422.0
18" TO 19"	323.0	440.0
19" TO 20"	335.0	457.0
20" TO 21"	348.0	474.0
21" TO 22"	360.0	492.0
22" TO 23"	373.0	510.0
23" TO 24"	385.0	528.0
EA. INCH ADD	10.3	17.5
CONE FAST ADD	20.0	30.6
NEOPRENE WATERSEAL ADD	32.0	64.0

THIS PRODUCT REQUIRES PROPER ENGINEERING

PLASTIC CONEFAST COIL CONES



- REMOVAL TOOL ALSO AVAILABLE

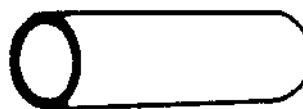
CODE	SIZE	WEIGHT	PACKAGED
CNFST12	1/2" X 1" SETBACK	4.5/C	EACH
CNFST34	3/4" X 1" SETBACK	6.5/C	EACH
CNFST10	1" X 2" SETBACK	17.0/C	EACH
CNFST14	1-1/4" X 2" SETBACK	18.0/C	EACH

SMOOTH STEEL DOWELS

- ANY DIAMETER
- ANY LENGTH
- SAW CUT ENDS
- PLAIN, PAINTED, EPOXY COATED OR STAINLESS
- TIE BARS AVAILABLE



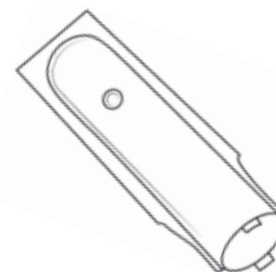
CODE	SIZE	WEIGHT	PACKAGED
DL1212	1/2" X 12"	0.67/EA	EACH
DL1218	1/2" X 18"	1.00/EA	EACH
DL1224	1/2" X 24"	1.34/EA	EACH
DL5818	5/8" X 18"	1.56/EA	EACH
DL5824	5/8" X 24"	2.09/EA	EACH
DL3416	3/4" X 16"	2.00/EA	EACH
DL3418	3/4" X 18"	2.25/EA	EACH
DL3424	3/4" X 24"	3.00/EA	EACH

OTHER SIZES AVAILABLE UPON REQUEST***PLASTIC DOWEL CAPS***

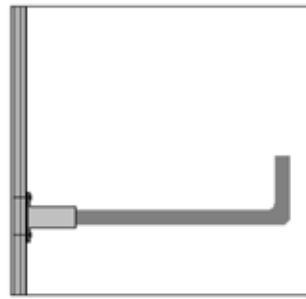
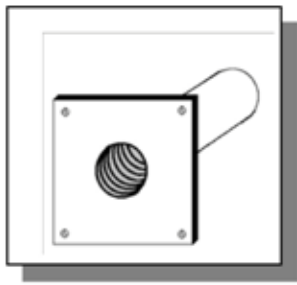
CODE	SIZE	WEIGHT	PACKAGED
DCP124	1/2" X 4"	2.2/C	2000/BOX
DCP126	1/2" X 6"	3.2/C	2000/BOX
DCP584	5/8" X 4"	2.6/C	2000/BOX
DCP344	3/4" X 4"	3.0/C	2000/BOX
DCP346	3/4" X 6"	4.4/C	1000/BOX
DCP784	7/8" X 4"	3.0/C	2000/BOX
DCP104	1" X 4"	3.6/C	1000/BOX
DCP114	1-1/4" X 4"	4.5/C	1000/BOX
DCP112	1-1/2" X 4"	5.3/C	1000/BOX

METAL DOWEL CAPS

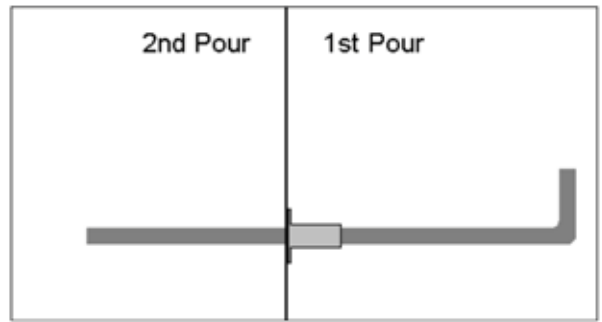
CODE	SIZE	WEIGHT	PACKAGED
DCM585	5/8" X 5	.089/EACH	100/BOX
DCM345	3/4 x 5	0.1/EACH	100/BOX
DCM15	1 x 5	0.135/EACH	100/BOX
DCM1145	1-1/4 x 5	0.14/EACH	100/BOX
DCM1125	1-1/2 x 5	0.147/EACH	100/BOX



DOWEL BAR SYSTEM



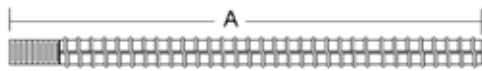
Installation of Splice Bar



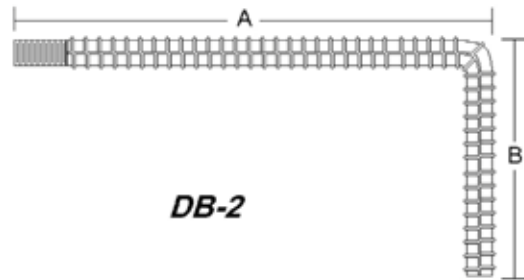
Completed Installation

CODE	BAR SIZE	THREAD DIAMETER	WEIGHT
DBR012	#4 REBAR	1/2"	0.2/EA
DBR058	#5 REBAR	5/8"	0.3/EA
DBR034	#6 REBAR	3/4"	0.4/EA
DBR078	#7 REBAR	7/8"	0.5/EA
DBR100	#8 REBAR	1"	0.7/EA
DBR118	#9 REBAR	1-1/8"	1.1/EA
DBR114	#10 REBAR	1-1/4"	1.7/EA
DBR138	#11 REBAR	1-1/2"	2.2/EA

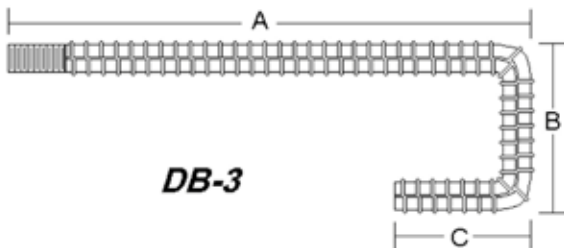
SPLICE BARS



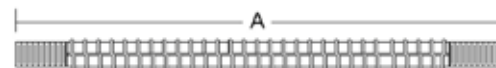
DB-1



DB-2



DB-3



DB-4

CALL FOR PRICE AND AVAILABILITY

MUSHROOM BAR GUARDS

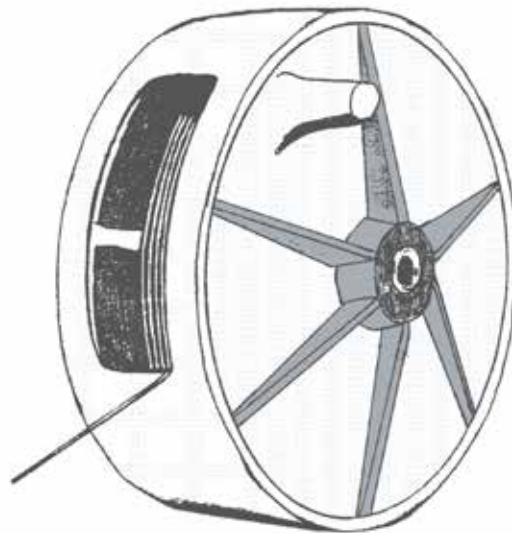
- **NOT** TO BE USED FOR IMPALEMENT PROTECTION



CODE	SIZE	WEIGHT	PACKAGED
D10BAR	UP TO #9 BAR	8.0/C	100/BOX

TIE WIRE REELS

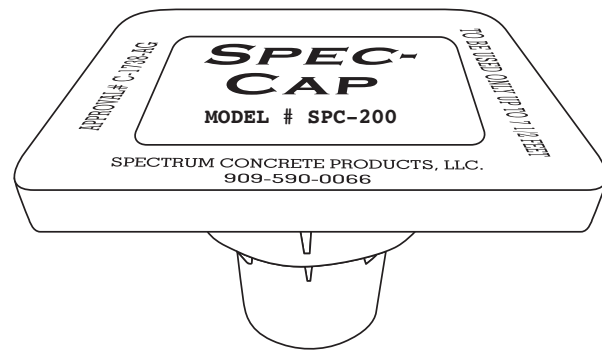
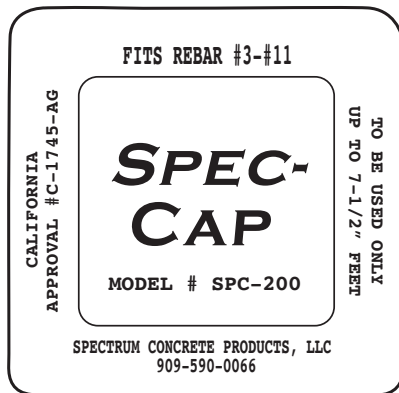
- AVAILABLE IN BOTH PLASTIC AND METAL



CODE	COLOR	WEIGHT	PACKAGED
REELM	GREY	2.0/EA	20/CTN
REELP	ORANGE	1.0/EA	20/CTN

SPEC-CAP IMPALMENT REBAR COVER

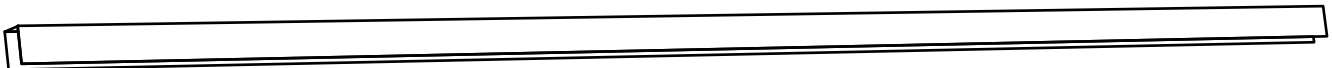
- CAL OSHA APPROVAL #C-1745-AG
- MEETS FED. OSHA SPEC #1926.701(B)
- THE SPEC-CAP IS DESIGNED FOR USE AT OR ABOVE GRADE
- INTERNALLY REINFORCED WITH A CONCAVE STEEL PLATE
- SAFETY ORANGE FOR HIGH VISIBILITY
- PACKED IN BOXES OF 50PCS PER BOX
- **THE SPEC-CAP FITS REBAR SIZES #3-#11**



PRODUCT CODE	WEIGHT	PACKAGED	SIZE
SPC200	0.35 / EACH	50 / BOX	UP TO #11

STEEL REBAR TROUGHS

- USED AS AN ALTERNATIVE FOR REBAR IMPLAEMENT CAPS
- MADE FROM 14GA STEEL
- AVAILABLE IN 14GA X 10FT. LENGTHS

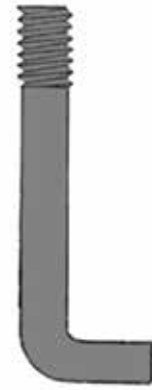


PRODUCT CODE	WEIGHT	PACKAGED	SIZE
RBRCVR11296	15.35 LBS.	EACH	14GA x 8FT.
RBRCVR112120	19.2 LBS.	EACH	14GA x 10FT.

SPECIAL ORDER ANCHOR BOLTS

- LARGE DIAMETERS
- ANY LENGTH
- QUICK SERVICE

CALL FOR PRICE AND AVAILABILITY

***BRICK TIES, CORRUGATED TIES***

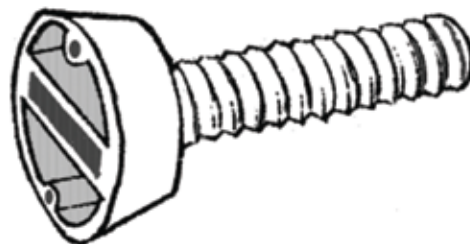
- DESIGNED TO ANCHOR MASONRY TO MASONRY.
- PROVIDES A CONNECTION BETWEEN THE WOOD STRUCTURE AND BRICK FACE.

CODE	SIZE	PACKAGED
BRICKTIE	22g X 6"	500/BOX

-REPEATED BENDING WILL WEAKEN THE STRENGTH OF THE TIE.

***PLASTIC COIL LOOP PROTECTORS***

- MUST BE COATED WITH FORM RETARDER FOR REMOVAL

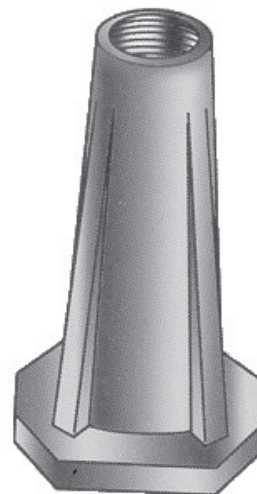


CODE	SIZE	WEIGHT	PACKAGED
LPPR12	1/2" DIA.	5.7/C	250/BOX
LPPR34	3/4" DIA.	8.0/C	250/BOX
LPPR10	1" DIA.	16.1/C	150/BOX

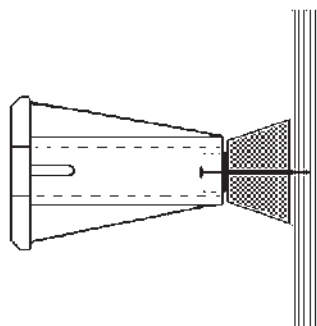
PRECAST INSERTS

- N.C. THREADED
- ZINC PLATED

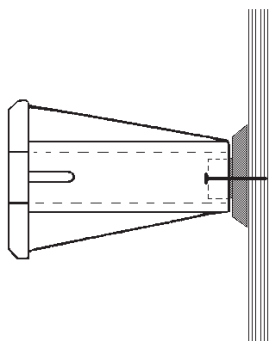
BOLT SIZE	LENGTH	THREAD DEPTH	3500_psi *SWL	5000_psi *SWL
1/2"	2-7/8"	2-1/2"	2700 LBS	n/a
5/8"	2-7/8"	2-1/2"	3340 LBS	n/a
3/4"	3"	2-1/2"	n/a	4090 lbs.



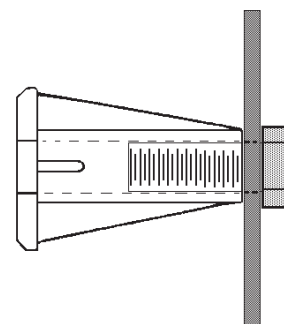
***APPROX. 4:1 SAFETY FACTOR**



1" Setback Plug



Standard threaded plug



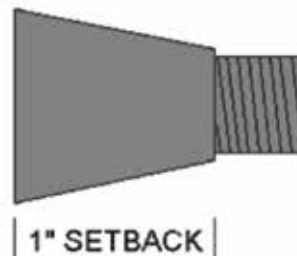
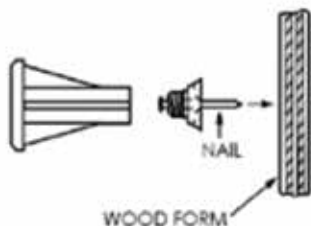
Steel form w/template bolt

THIS PRODUCT REQUIRES PROPER ENGINEERING

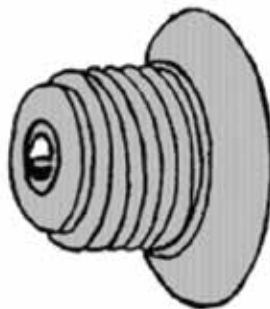
CODE	SIZE	WEIGHT	PACKAGED
STAR12	1/2" x 2-7/8"	30.0/C	100/BOX
STAR58	5/8" x 2-7/8"	36.0/C	100/BOX
STAR34	3/4" x 3"	48.0/C	100/BOX

PLASTIC THREADED SET-BACK PLUGS

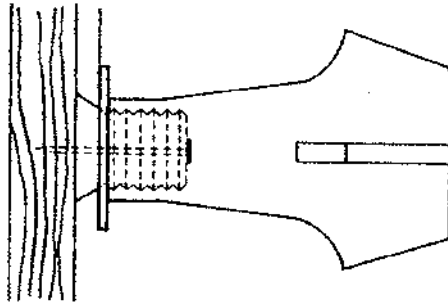
- FOR USE WITH PRECAST INSERTS ONLY



CODE	SIZE	WEIGHT	PACKAGED
PLG012	1/2"	2.4/C	EACH
PLG058	5/8"	3.0/C	EACH
PLG034	3/4"	3.2/C	EACH

THREADED PLASTIC SETTING PLUGS

CODE	SIZE	WEIGHT	PACKAGED
THRD38	3/8"	0.5/C	EACH
THRD12	1/2"	0.6/C	EACH
THRD58	5/8"	0.8/C	EACH
THRD34	3/4"	1.0/C	EACH
THRD78	7/8"	1.7/C	EACH
THRD10	1"	2.0/C	EACH

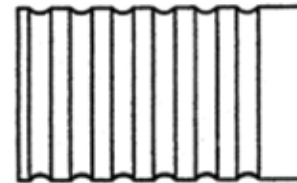
HIGH TENSILE DUCTILE INSERTS

CODE	SIZE	WEIGHT	TENSION
INS038	3/8"	25.0/C	900LBS.
INS012	1/2"	31.3/C	1,500LBS.
INS058	5/8"	50.0/C	2,100LBS.
INS034	3/4"	56.3/C	2,980LBS.
INS078	7/8"	87.5/C	3,950LBS.
INS100	1"	100.0/C	4,800LBS.

**THIS PRODUCT REQUIRES PROPER ENGINEERING
TENSION LOAD BASED ON 2000psi CONCRETE
SAFE WORKING LOAD IS BASED APPROX. ON A 3:1 SAFETY FACTOR**

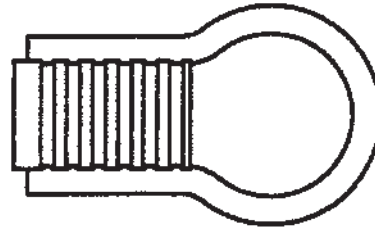
PLAIN FERRULE INSERTS

- FOR FABRICATION PURPOSES
- NOT TO BE USED ALONE
- CLOSED BOTTOM



CODE	SIZE	WEIGHT	PACKAGED
FNI038	3/8"	5.0/C	EACH
FNI012	1/2"	7.5/C	EACH
FNI058	5/8"	15.0/C	EACH
FNI034	3/4"	17.5/C	EACH
FNI078	7/8"	34.0/C	EACH
FNI100	1"	39.0/C	EACH

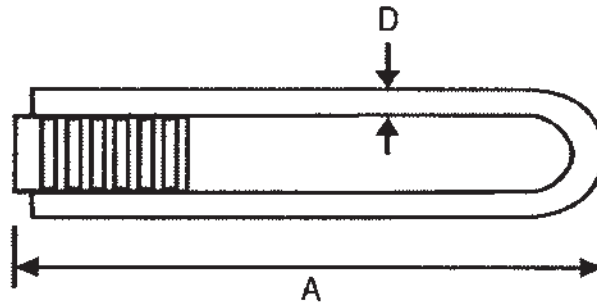
PRODUCT REQUIRES PROPER ENGINEERING

FERRULE LOOP INSERTS

CODE	SIZE	WEIGHT	PACKAGED
FERR38	3/8"	14.0/C	EACH
FERR12	1/2"	21.0/C	EACH
FERR58	5/8"	34.0/C	EACH
FERR34	3/4"	38.0/C	EACH
FERR78	7/8"	52.0/C	EACH
FERR10	1"	57.0/C	EACH

THIS PRODUCT REQUIRES PROPER ENGINEERING

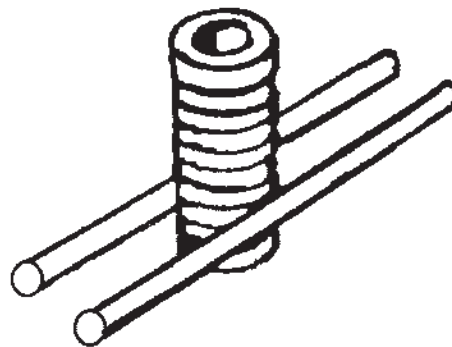
INSERTS CAN BE ELECTRO-GALVANIZED OR STAINLESS STEEL COATED.
FOR SAFE WORKING LOADS CALL OUR CUSTOMER SERVICE DEPARTMENT.

STRAIGHT FERRULE LOOP INSERTS

CODE	SIZE	WEIGHT	PACKAGED
FLS124	1/2" X 4-1/8"	25.0/C	EACH
FLS126	1/2" X 6-1/8"	38.0/C	EACH
FLS584	5/8" X 4-1/8"	35.0/C	EACH
FLS586	5/8" X 6-1/8"	48.0/C	EACH
FLS344	3/4" X 4-1/8"	54.0/C	EACH
FLS346	3/4" X 6-1/8"	67.0/C	EACH
FLS786	7/8" X 6-1/8"	75.0/C	EACH
FLS106	1" X 6-1/8"	75.0/C	EACH
FLS108	1" X 8-1/8"	103.0/C	EACH

THIS PRODUCT REQUIRES PROPER ENGINEERING

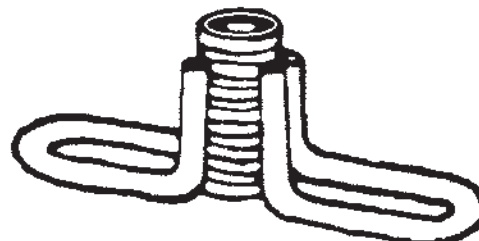
INSERTS CAN BE ELECTRO-GALVANIZED OR STAINLESS STEEL COATED.
FOR SAFE WORKING LOADS CALL OUR CUSTOMER SERVICE DEPARTMENT.

FERRULE THIN SLAB INSERTS

CODE	SIZE	WEIGHT	PACKAGED
FTS038	3/8"	18.0/C	EACH
FTS012	1/2"	20.0/C	EACH
FTS058	5/8"	28.0/C	EACH
FTS034	3/4"	31.0/C	EACH
FTS078	7/8"	59.0/C	EACH
FTS100	1"	51.0/C	EACH

THIS PRODUCT REQUIRES PROPER ENGINEERING

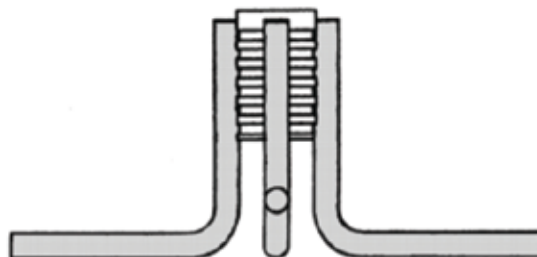
INSERTS CAN BE ELECTRO-GALVANIZED OR STAINLESS STEEL COATED.
FOR SAFE WORKING LOADS CALL OUR CUSTOMER SERVICE DEPARTMENT

FLARED FERRULE INSERTS

CODE	SIZE	WEIGHT	PACKAGED
FFI121	1/2" X 1-5/8"	25.0/C	EACH
FFI582	5/8" X 2-3/8"	45.0/C	EACH
FFI342	3/4" X 2-3/8"	48.0/C	EACH
FFI343	3/4" X 3-1/2"	67.0/C	EACH
FFI103	1" X 3-1/2"	85.0/C	EACH
FFI104	1" X 4-1/2"	107.0/C	EACH

THIS PRODUCT REQUIRES PROPER ENGINEERING

INSERTS CAN BE ELECTRO-GALVANIZED OR STAINLESS STEEL COATED.
FOR SAFE WORKING LOADS CALL OUR CUSTOMER SERVICE DEPARTMENT

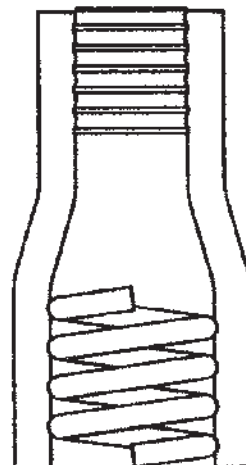
FERRULE 4-LEG INSERTS

CODE	SIZE	WEIGHT	PACKAGED
F4L343	3/4" X 3-1/8"	71.0/C	EACH
F4L104	1" X 4-1/8"	99.0/C	EACH

THIS PRODUCT REQUIRES PROPER ENGINEERING

INSERTS CAN BE ELECTRO-GALVANIZED OR STAINLESS STEEL COATED.

FOR SAFE WORKING LOADS CALL OUR CUSTOMER SERVICE DEPARTMENT

OPEN FERRULE INSERTS

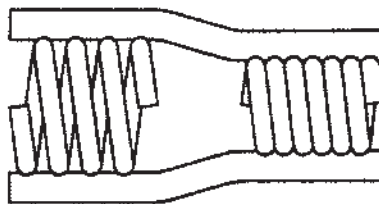
CODE	SIZE	THREAD	WEIGHT
OFI344	3/4" X 4-1/2"	2 STRUT N.C.	60.0/C
OFI105	1" X 5-1/2"	2 STRUT N.C.	115.0/C
OFI107	1" X 7-1/2"	4 STRUT N.C.	215.0/C
OFI147	1-1/4" X 7-1/2"	4 STRUT N.C.	240.0/C
OFI129	1-1/2" X 9-1/2"	6 STRUT N.C.	420.0/C

THIS PRODUCT REQUIRES PROPER ENGINEERING

INSERTS CAN BE ELECTRO-GALVANIZED OR STAINLESS STEEL COATED.

MOUNTING WASHERS AVAILABLE ON SPECIAL ORDER

FOR SAFE WORKING LOADS CALL OUR CUSTOMER SERVICE DEPARTMENT

OPEN COIL INSERTS

CODE	SIZE	WEIGHT	PACKAGED
OCI344	3/4" X 4-1/2"	60.0/C	EACH
OCI105	1" X 5-1/2"	115.0/C	EACH
OCI107	1" X 7-1/2"	215.0/C	EACH
OCI147	1-1/4" X 7-1/2"	240.0/C	EACH
OCI129	1-1/2" X 9-1/2"	420.0/C	EACH

THIS PRODUCT REQUIRES PROPER ENGINEERING

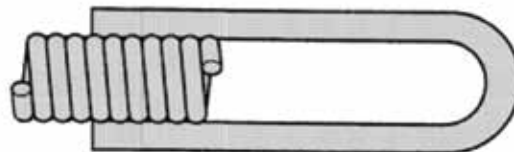
INSERTS CAN BE ELECTRO-GALVANIZED OR STAINLESS STEEL COATED.

MOUNTING WASHERS AVAILABLE ON SPECIAL ORDER

FOR SAFE WORKING LOADS CALL OUR CUSTOMER SERVICE DEPARTMENT

STRAIGHT COIL LOOP INSERTS

STANDARD



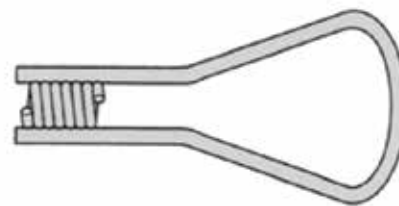
CONEFAST

CODE	SIZE	WEIGHT	APPROX. SWL 4:1
SCL124	1/2" X 4"	18.0/C	2,250LBS
SCL126	1/2" X 6"	30.2/C	3,000LBS
SCL344	3/4" X 4"	37.6/C	2,250LBS
SCL346	3/4" X 6"	39.2/C	3,750LBS
SCL106	1" X 6"	80.5/C	3,750LBS
SCL108	1" X 8"	95.0/C	3,750LBS

THIS PRODUCT REQUIRES PROPER ENGINEERING

INSERTS CAN BE ELECTRO-GALVANIZED OR STAINLESS STEEL COATED.

TENSION LOAD APPROX. BASED ON SAFETY FACTOR OF 4:1 IN 3,000 PSI NORMAL WEIGHT CONCRETE

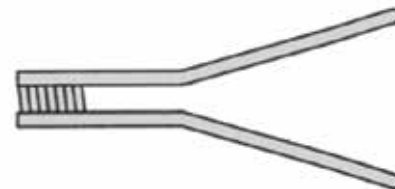
FLARED COIL LOOP INSERTS, SINGLE

CODE	SIZE	WEIGHT	APPROX. SWL 4:1
FCL346	3/4" X 6"	66.0/C	3,750LBS.
FCL349	3/4" X 9" HVY.	80.0/C	3,750LBS.
FCL341	3/4" X 12" HVY.	111.0/C	4,750LBS.
FCL194	1" X 9"	120.0/C	4,750LBS.
FCL198	1" X 9" HVY.	179.0/C	8,000LBS.
FCL124	1" X 12"	151.0/C	4,750LBS.
FCL128	1" X 12" HVY.	178.0/C	8,000LBS.
FCL144	1-1/4" X 12"	147.0/C	4,750LBS.
FCL148	1-1/4" X 12" HVY	185.0/C	8,000LBS.

THIS PRODUCT REQUIRES PROPER ENGINEERING

INSERTS CAN BE ELECTRO-GALVANIZED OR STAINLESS STEEL COATED.

TENSION LOAD IS APPROXIMATELY BASED ON SAFETY FACTOR OF 4:1

FLARED COIL LOOP INSERTS, DOUBLE

CODE	SIZE	WEIGHT	APPROX. SWL 4:1
FCD10S	1" X 12"	237.0/C	9,500LBS.
FCD10H	1" X 12" HVY.	310.0/C	13,500LBS.
FCD14S	1-1/4" X 12"	265.0/C	9,500LBS.
FCD14H	1-1/4" X 12" HVY.	318.0/C	13,500LBS.
FCD12S	1-1/2" X 12"	265.0/C	9,500LBS.
FCD12H	1-1/2" X 12" HVY.	340.0/C	13,500LBS.

THIS PRODUCT REQUIRES PROPER ENGINEERING

INSERTS CAN BE ELECTRO-GALVANIZED OR STAINLESS STEEL COATED.

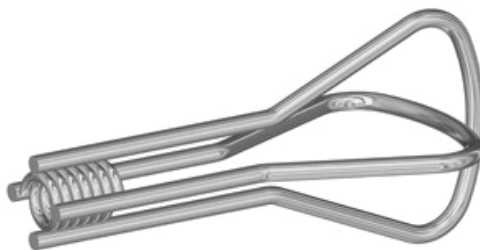
TENSION LOAD IS APPROXIMATELY BASED ON SAFETY FACTOR OF 4:1

STRAIGHT COIL LOOP INSERTS, CRISS-CROSS

CODE	SIZE	WEIGHT	APPROX. SWL 4:1
CC3409	3/4" X 9"	70.0/C	3,700LBS.
CC3412	3/4" X 12"	90.0/C	4,600LBS.
CC1009	1" X 9"	77.0/C	4,500LBS.
CC1012	1" X 12"	97.0/C	6,500LBS.
CC1149	1-1/4" X 9"	285.0/C	4,700LBS.
CC11412	1-1/4" X 12"	315.0/C	7,500LBS.

THIS PRODUCT REQUIRES PROPER ENGINEERING

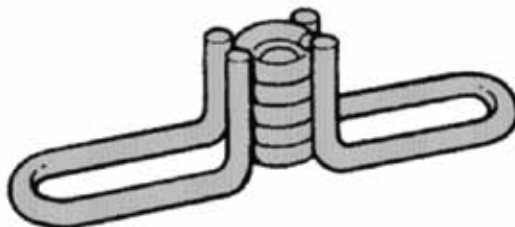
INSERTS CAN BE ELECTRO-GALVANIZED OR STAINLESS STEEL COATED.
TENSION LOAD IS APPROXIMATELY BASED ON SAFETY FACTOR OF 4:1

FLARED COIL LOOP INSERTS, CRISS-CROSS

CODE	SIZE	WEIGHT	APPROX. SWL 4:1
CCD10S	1" X 12"	237.0/C	9,500LBS.
CCD14S	1-1/4" X 12"	245.0/C	9,500LBS.
CCD12S	1-1/2" X 12"	266.0/C	9,500LBS.
CCD10H	1" X 12" HVY.	312.0/C	13,500LBS.
CCD14H	1-1/4" X 12" HVY.	320.0/C	13,500LBS.
CCD12H	1-1/2" X 12" HVY.	341.0/C	13,500LBS.

THIS PRODUCT REQUIRES PROPER ENGINEERING

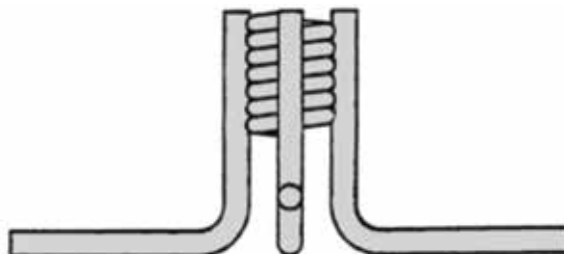
INSERTS CAN BE ELECTRO-GALVANIZED OR STAINLESS STEEL COATED.
TENSION LOAD IS APPROXIMATELY BASED ON SAFETY FACTOR OF 4:1

FLARED COIL THIN SLAB INSERTS

CODE	SIZE	WEIGHT	APPROX.SWL 4:1
CTS012	1/2" X 1-3/4"	26.0/C	1,520LBS.
CTS342	3/4" X 2-5/16"	49.0/C	2,000LBS.
CTS343	3/4" X 3-1/2"	87.0/C	3,400LBS.
CTS103	1" X 2-5/16"	86.0/C	3,400LBS.
CTS104	1" X 4-1/2"	105.0/C	4,750LBS.

THIS PRODUCT REQUIRES PROPER ENGINEERING

INSERTS CAN BE ELECTRO-GALVANIZED OR STAINLESS STEEL COATED.
TENSION LOAD IS APPROXIMATELY BASED ON SAFETY FACTOR OF 4:1

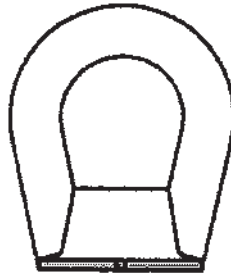
COIL 4-LEG INSERTS, THIN SLAB

CODE	SIZE	WEIGHT	APPROX. SWL 4:1
CLL343	3/4" X 3"	63.0/C	2,000LBS.
CLL104	1" X 4"	108.0/C	3,000LBS.
CLL114	1-1/4" X 4"	148.0/C	4,000LBS.
CLL112	1-1/2" X 4"	158.0/C	4,000LBS.

THIS PRODUCT REQUIRES PROPER ENGINEERING

INSERTS CAN BE ELECTRO-GALVANIZED OR STAINLESS STEEL COATED.
TENSION LOAD IS APPROXIMATELY BASED ON SAFETY FACTOR OF 4:1

COIL EYE NUTS



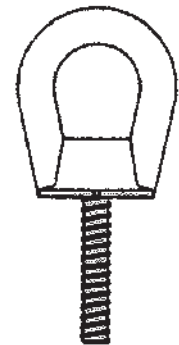
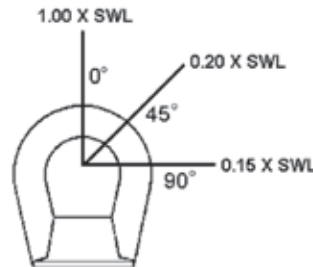
CODE	SIZE	HEIGHT	WEIGHT
CEN012	1/2" DIA.	3-1/4"	.7/EA
CEN034	3/4" DIA.	3-1/2"	1.2/EA
CEN100	1" DIA.	5"	2.9/EA
CEN114	1-1/4" DIA.	6-1/4"	6.0/EA
CEN112	1-1/2" DIA.	6-1/4"	6.3/EA

THIS PRODUCT REQUIRES PROPER ENGINEERING

COIL EYE BOLTS

Load Reduction Formula

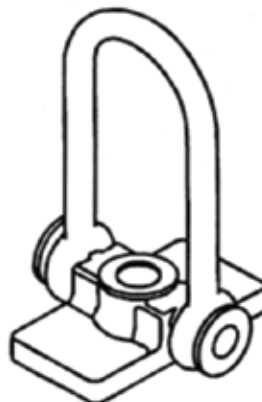
BOLT DIAMETER	APPROX. SWL TENSION 5:1 Safety Factor
1/2"	2700 LBS.
3/4"	3600 LBS.
1"	7200 LBS.
1-1/4"	10600 LBS.



CODE	SIZE	LENGTH	WEIGHT
CEB012	1/2" DIA.	2-1/2"	.8/EA
CEB034	3/4" DIA.	3"	1.6/EA
CEB100	1" DIA.	3-1/2"	3.7/EA
CEB114	1-1/4" DIA.	4"	4.7/EA
CEB112	1-1/2" DIA.	6"	9.3/EA

THIS PRODUCT REQUIRES PROPER ENGINEERING

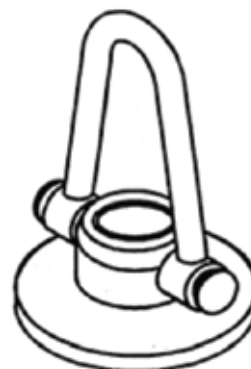
- CUSTOM LENGTHS AVAILABLE UPON REQUEST

SINGLE LIFTING PLATES

CODE	BOLT DIA.	MIN. BOLT LENGTH	APPROX. SWL 5:1	WEIGHT
SLP034	3/4"	2-1/2"	9,000/LBS	5.0/EA
SLP100	1"	3"	9,000/LBS	5.0/EA

THIS PRODUCT REQUIRES PROPER ENGINEERING

LIFT PLATE MUST HAVE FULL BEARING AGAINST CONCRETE AT ALL TIMES DURING LOADING.

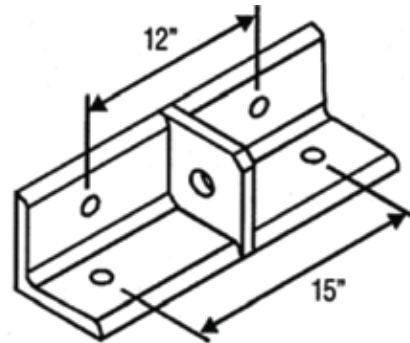
DUAL SWIVEL LIFTING PLATES

CODE	BOLT DIA.	MIN. BOLT LENGTH	APPROX. SWL 5:1	WEIGHT
DLP100	1"	5"	9,000/LBS	8.0/EA
DLP114	1-1/4"	6"	13,500/LBS	17.0/EA
DLP112	1-1/2"	6"	13,500/LBS	17.0/EA

THIS PRODUCT REQUIRES PROPER ENGINEERING

LIFT PLATE MUST HAVE FULL BEARING AGAINST CONCRETE AT ALL TIMES DURING LOADING.

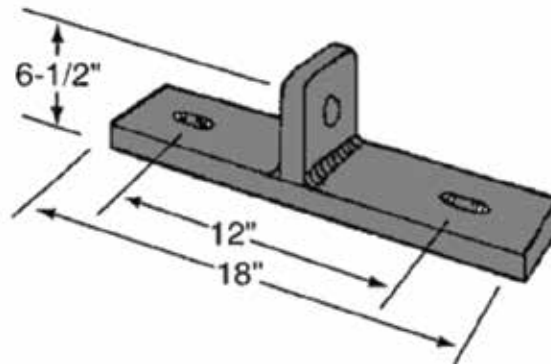
DOUBLE ANGLE LIFT PLATE



CODE	BOLT DIA.	MIN. BOLT LENGTH	WEIGHT
DALP10	1" TO 1-1/2"	4"	53.0/EA

THIS PRODUCT REQUIRES PROPER ENGINEERING

EDGE LIFTING PLATE

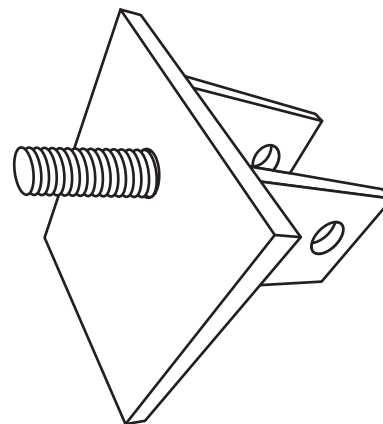


CODE	BOLT DIA.	MIN. BOLT LENGTH	WEIGHT
DELP10	3/4" & 1" BOLTS	4"	23.0/EA

THIS PRODUCT REQUIRES PROPER ENGINEERING

GANG FORM BRACE ATTACHMENT BRACKET

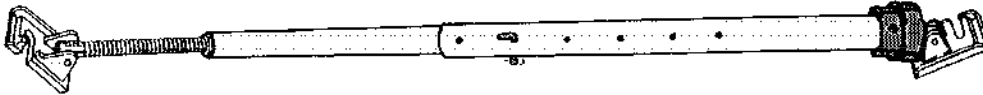
- HELPS TO CONNECT TILT-UP BRACES TO A DOUBLE CHANNEL WALER



CODE	WEIGHT	PACKAGED
GANGFMBB	8.0/EA	EACH

TILT-UP BRACES, D1, D4 & D5

- WIDE RANGE OF ADJUSTMENT
- VERSATILE



CODE	TYPE	LENGTH	WEIGHT
D1TUBR	D1 - LOW WALL	8'1" TO 14'5"	95.0/EA
D4TUBR	D4 - STANDARD	14' TO 23'6"	130.0/EA
D5TUBR	D5 - LONG	23' TO 39'	208.0/EA

THIS PRODUCT REQUIRES PROPER ENGINEERING

TILT-UP BRACES, SUPER D8, D9 & D10

- 4" PIPE
- 18" OF ADJUSTMENT

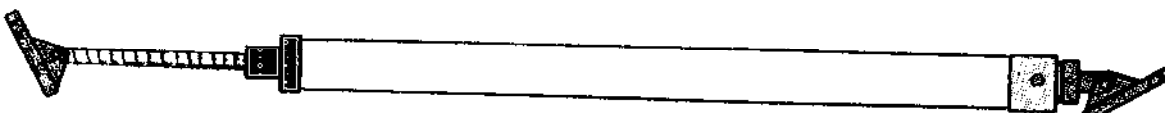
CODE	TYPE	LENGTH	WEIGHT
D8TUBR	D8 - SUPER	21'3" TO 22'9"	130.0/EA

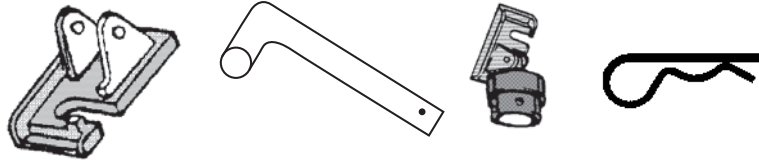
THIS PRODUCT REQUIRES PROPER ENGINEERING

TILT-UP BRACES, HEAVY DUTY D12, D14, D15 & D16

- 5-1/2" PIPE
- 18" OF ADJUSTMENT

CODE	TYPE	LENGTH	WEIGHT
D12TUBR	D12 - HEAVY DUTY	32' FIXED	245.0/EA
D14TUBR	D14 - HEAVY DUTY	42' FIXED	382.0/EA
D15TUBR	D15 - HEAVY DUTY	52' FIXED	410.0/EA
D16TUBR	D16 - HEAVY DUTY	37' FIXED	360.0/EA



TILT-UP BRACE PARTS

- D-1 & D-4 BRACE**

CODE	PART	WEIGHT
D1INNR	D1 INNER PIPE	25.6/EA
D1OUTR	D1 OUTER PIPE	40.5/EA
D4INNR	D4 INNER PIPE	43.8/EA
D4OUTR	D4 OUTER PIPE	69.5/EA
TUSWIV	SWIVEL	3.5/EA
TUSHNT	SHOULDER NUT	1.5/EA
TUTHRD	THREADED ROD	7.0/EA
TUSHOE	SHOE	4.0/EA
TULPIN	L-PIN	.6/EA
PINCLP	PIN CLIP	.039/EA

- D-5 BRACE**

CODE	PART	WEIGHT
D5INNR	INNER PIPE	76.7/EA
D5OUTR	OUTER PIPE	121.6/EA
TUSWIV	SWIVEL	3.5/EA
TUSHNT	SHOULDER NUT	1.5/EA
TUTHRD	THREADED ROD	7.0/EA
TUSHOE	SHOE	4.0/EA
TULPIN	L-PIN	.6/EA
PINCLP	PIN CLIP	.039/EA

- D-8 BRACE**

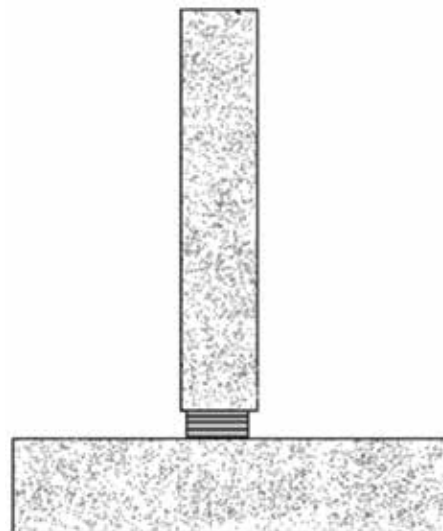
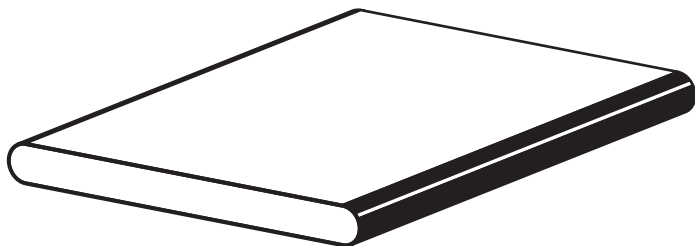
CODE	PART	WEIGHT
D8PIPE	20' PIPE	97.0/EA
D8EX05	5' EXTENSION	23.0/EA
D8EX10	10' EXTENSION	46.0/EA
D8CPLR	COUPLER	42.0/EA
D8SWIV	SWIVEL	12.0/EA
D8NUTC	NUT COLLAR	5.0/EA
D8THRD	THREADED ROD	8.5/EA
TUSHOE	SHOE	4.0/EA

- D-12 BRACE**

CODE	PART	WEIGHT
D12PIPE	30' PIPE	235.0/EA
TUSWIV12	SWIVEL	13.0/EA
D12NUTC	NUT COLLAR	11.0/EA
D12THRD	THREADED ROD	8.5/EA
TUSHOE12	SHOE	7.0/EA

PVC SHIMS

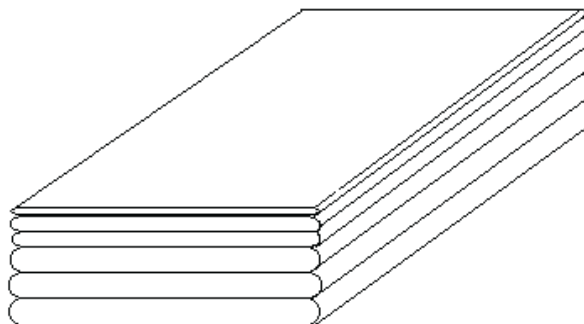
- FOR TILT-UP OR PRECAST
- 10K PSI LOAD CAPACITY
- NON-SLIP TEXTURED
- CHEMICAL RESISTANT



CODE	SIZE	WEIGHT	PACKAGED
SHIM16	1/16" X 4" X 6"	5.7/C	800/BOX
SHIM18	1/8" X 4" X 6"	11.3/C	400/BOX
SHIM14	1/4" X 4" X 6"	22.5/C	200/BOX

PVC SHIM PACKS

- PACK CONTAINS: 1 EA 1/16"
- 2 EA 1/8"
- 3 EA 1/4"



CODE	SIZE	WEIGHT	PACKAGED
SHIMPK	1-1/16" X 4" X 6"	.96/EA	50/BOX

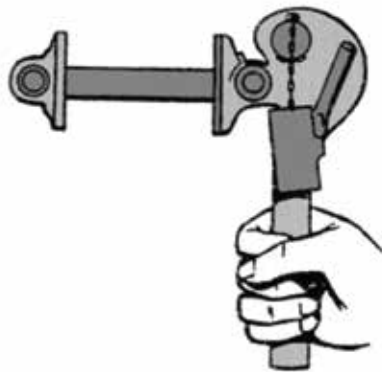
4 X 4 SHORE CLAMPS



CODE	WEIGHT	PACKAGED
SHRCLMP	2.67/EA	EACH

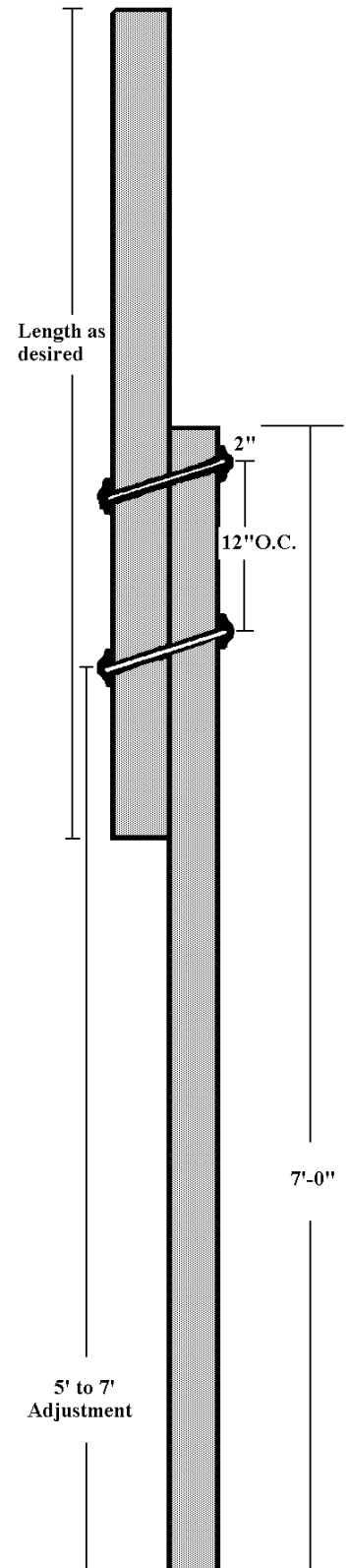
THIS PRODUCT REQUIRES PROPER ENGINEERING

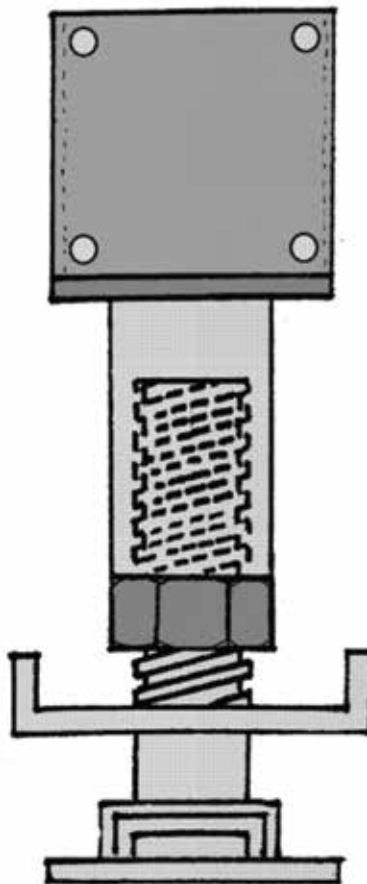
SHORE JACKS



CODE	WEIGHT	PACKAGED
SHRJCK	14.0/EA	EACH

THIS PRODUCT REQUIRES PROPER ENGINEERING



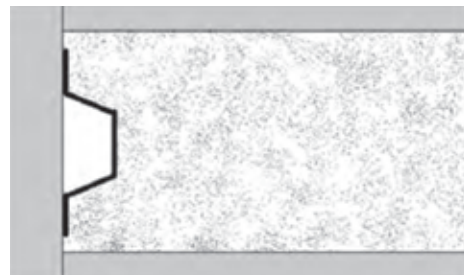
ADJUSTABLE SCREW JACKS**4 X 4 SCREW JACKS: APPROX. 15,000 LBS. SWL (2:1 SF)*****6" OF ADJUSTMENT***

SIZE	CODE	WEIGHT
4 X 4	SCWJCK	12.0/EA

THIS PRODUCT REQUIRES PROPER ENGINEERING

RESHORE SPRINGS

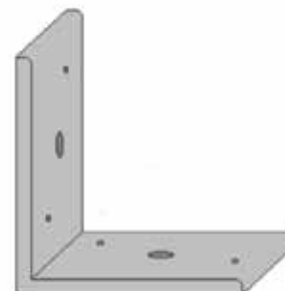
CODE	WEIGHT	PACKAGED
RESHOR	.2/EA	100/BOX

PLASTIC KEYWAY

CODE	SIZE	WEIGHT	PACKAGED
KEY218	2-1/8" X 10'	9.0/CLF	500FT/BOX
KEY312	3-1/2" X 10'	15.3/CLF	300FT/BOX

TILT-UP ANGLE CLIPS

- HEAVY DUTY
- DURABLE



CODE	SIZE	WEIGHT	PACKAGED
TUACLP	5/16" X 5" X 5"	1.82/EA	EACH

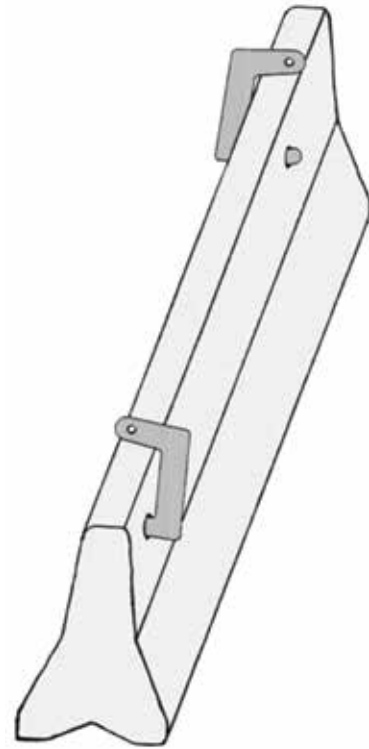
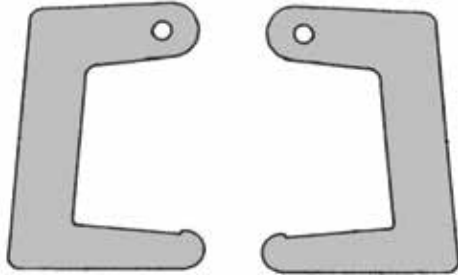
EMERGENCY LIFTING PLATES, PANIC PLATES

CODE	WEIGHT	PACKAGED
ELFTPLT	33 LBS	EACH

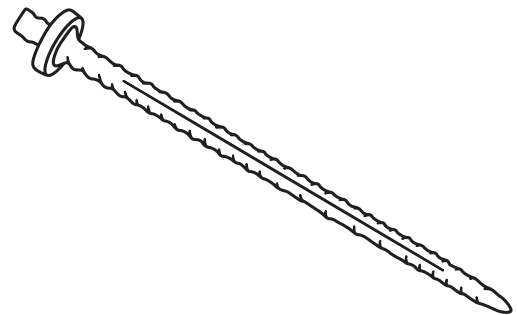


K-RAIL HOOKS

- REQUIRES 2 PCS. PER SET



CODE	WEIGHT	PACKAGED
KRHOOK	82.0/SET	SET

K-RAIL PINS***K-RAIL STAKES***

CODE	WEIGHT	PACKAGED
KRLPINHDG	10.0/EA	EACH
KRLSTK	5.0/EA	EACH

- CAL-TRANS APPROVED.
- SPECIAL SIZE PINS AND STAKES AVAILABLE UPON REQUEST.
- K-RAIL STAKES ARE HOT-DIPPED GALVANIZED

INDEX

A

A BRACKETS	47
ACME NUTWASHERS	5
ACME THREADED ROD	14
ADJ. COIL BOLTS	13
ADJ. JOIST HANGERS	18
ADJ. SCREW JACKS	83
ADJ. WELDED ANGLE BRACKETS	7
ADJUSTMENT PLATES	22
ALIGNER BRACES	54
ALIGNER CLAMPS	52
ALL THREAD ROD	14
ANCHOR BOLTS	65
ANGLE CLIPS	84
ANGLE LIFTING PLATES	78
ANGLE TIE BRACKETS	7

B

BAR GUARDS	64
BASE TIES	45
BATTER WASHERS	6
BEAM CLAMPS	35
BEAM CLIPS	35
BEAM ENDS	37
BOLT STANDS	17
BRACE PARTS	80
BRACE PLATES	37,78,84
BRACES	79
BRACKET EXTENDERS	22
BREAK-BACK WRENCHES	44
BRICK TIES	65
BRIDGE OVERHANG BRACKETS	19-23
BURKE BARS	56

C

C BRACKETS	47
CAN OPENERS	35
CAPITAL ENTRY FORMS	36
CAPPED STAKES	85
CARZATE WIRE HOOKS	30
CATHEADS	5
C-CLAMPS	35
CENTER RODS	15
CHAMFER	48
CHASERS	10
CLOSED COUPLERS	15
COIL ANCHORS	44
COIL BOLTS, WELDED	8

COIL BOLTS	8
COIL COUPLERS	15
COIL EYE BOLTS	76
COIL EYE NUTS	76
COIL INNER RODS	15
COIL INSERTS	72-75
COIL LOOP INSERTS	72-75
COIL LOOP PROTECTORS	65
COIL NUTS	12
COIL NUTS, HEAVY HEX	12
COIL NUTS, LEFT HAND	12
COIL NUTWASHERS	5
COIL ROD	11
COIL ROD, LEFT HAND	11
COIL TIES	59
COIL WING NUTS	5
COLUMN BRACES	54
COLUMN CLAMP PIN & CHAIN	24
COLUMN CLAMPS	24
CONCRETE PLUGS	56
CONE FAST CONES	60
CONES, PUSH-FIT	10
CONSCREEDS	26
COOKIES	31
CORNER LOCKS	48
COUPLERS, COIL	15
COUPLERS, TILT-UP BRACE	80
COWBELLS	47
CRISS-CROSS COIL INSERTS	74
CUSTOM STEEL FABRICATION	36-37
CUT WASHERS	9

D

D-10 BAR GUARDS	63
D-49 BRIDGE OVERHANG BRACKET	22
DECK BOLTS	37
DECK SUPPORT BRACKETS	21
DELUXE SCAFFOLD BRACKETS	49
DIE CAST SCREED PADS	31
DON SCREEDS	26
DOUBLE CHANNEL WALERS	36
DOUBLE LIFTING PLATES	78
DOUBLE WALER BRACKETS	52
DOWEL BAR COUPLERS	62
DOWEL CAPS, METAL	61
DOWEL CAPS, PLASTIC	61
DOWELS, STEEL	63
DROP-IN COIL ANCHORS	44
DUAL LIFTING PLATES	77

E

ECONO-CLAMP	24
EDGE LIFTING PLATES	78

INDEX

EDGE OF DECK BRACKETS.....	37
EDGE OF DECK FORMS.....	37
EMERGENCY LIFTING PLATES	86
END PANS.....	37
EURO ROD.....	16
EURO THREAD SHE BOLTS.....	16
EURO WING NUTS	16
EYE BOLTS	76
EYE NUTS	76

F

FALSEWORK ACCESSORIES.....	35
FAST-SET FORM HANGERS	25
FERRULE INSERTS.....	68-71
FERRULES.....	68
FIT-UP BOLTS & NUTS.....	8
FLAT STAKE SCREED HOOKS.....	30
FLAT STAKES	27
FLAT TIES	55
FLAT WASHERS.....	6
FOOTING TIES.....	43
FORM ALIGNER BRACES.....	54
FORM ANGLE CLIPS.....	84
FORM BUTTONS	57
FORM HANGER BRACKETS.....	25
FORM PATCHES.....	57
FORM PLUGS	57
FORM SAVERS.....	62

G

GANG FORM BRACE PLATE.....	78
GANG FORM SCAFFOLD BRACKETS	36
GUARD RAIL POSTS.....	53
GUARD RAIL RECEPTICLE.....	22

H

HAND RAIL POSTS.....	36,53
HANDSET LOOP TIES	55
HAUNCH BRACKETS	36
HEADER FORM BRACKETS	28
HEAVY DUTY C-CLAMPS.....	35
HEAVY DUTY NUTWASHERS.....	5
HEAVY DUTY OVERHANG BRACKETS	23
HEAVY DUTY SCREED HOLDERS.....	34
HEAVY DUTY TILT-UP BRACES.....	79
HEAVY HEX COIL NUTS	12
HEAVY SNAPTIE WEDGES.....	46
HIGH STRENGTH SNAPTIES.....	41
HIGH TENSILE COIL ROD	11
HIGH TENSILE DUCTILE INSERT	68
HOOK BOLTS	4,13
HUB STAKES	28

I

I-BEAM CLIPS.....	35
IMPALEMENT CAPS.....	64
INNER RODS: COIL, EURO & NC.....	15
INSERTS, COIL LOOP	73-75
INSERTS, PRECAST	66

J

JAHN A BRACKETS	47
JAHN C BRACKETS	47
JAHN CORNERLOCKS	48
JAHN SCAFFOLD JACKS	49
JAHN SNAPTIE EXTENDERS.....	46
JANCO CLIPS.....	35
JAW-TYPE SNAPTIE WRENCHES.....	44
J-BOLTS.....	4
JOIST HANGERS	18

K

KEYPLATES	5
KEYPLATES, THREADED.....	5
KEYWAY, PLASTIC	84
K-RAIL HOOKS.....	85
K-RAIL PINS	85
K-RAIL STAKES.....	85

L

LACKEY BRACKETS	36
LAG BOLTS, TAPPED	9
LATH STAKES	28
LEFT HAND COIL NUTS	12
LEFT HAND COIL ROD	11
LIFTING PLATES.....	78
LINER CLAMPS	52
LOK STYLE COLUMN CLAMPS	52
LOOP PROTECTORS	65
LOOP TIES	55
LOW WALL BRACES.....	79
L-PINS.....	80

M

MAGNETIC SETTING TOOL	57
MATERIAL BINS.....	37
METAL DOWEL CAPS	61
METAL FORM PATCHES.....	57
METAL RIB	18
METAL TIE WIRE REELS	63
MIKE BRACKETS.....	7
MODULAR FORM SCAFFOLD BRACKETS.....	49
MUSHROOM CAPS.....	63

INDEX

N

N.C. ROD.....	14
NAIL POINT POSTS.....	32
NEOPRENE WATERSEALS	9
NUTWASHERS.....	5

O

OSHA CAPS.....	64
OVERHANG BRACKETS, 10K.....	23
OVERHANG BRACKETS, 28".....	19
OVERHANG BRACKETS, 42".....	20
OVERHANG BRACKETS, D-49	22
OVERHANG EXTENDERS.....	22

P

PAD POSTS.....	31
PANEL TIES	55
PANIC PLATES	84
PENCIL ROD CLAMPS	58
PENCIL ROD WRENCHES	58
PENCIL ROD	58
PERMANENT FORMWORK.....	18
PIN & CHAIN ASSEMBLIES.....	24
PIN CAPS	29
PIPE SCREED HOLDERS.....	33
PIPE SCREEDS.....	26
PIVOT BRACKETS.....	7
PLASTIC COIL PROTECTORS.....	65
PLASTIC CONES, SCREW-ON	60
PLASTIC DOWEL CAPS	61
PLASTIC FORM PLUGS	57
PLASTIC KEYWAY.....	84
PLASTIC PLUGS, THREADED	67
PLASTIC REBAR GUARDS	64
PLASTIC REBAR SADDLES.....	34
PLASTIC TIE WIRE REELS	64
PLATE TIES.....	42
PLATE WASHERS.....	6
PLY-HOLE PLUGS	57
PRECAST INSERTS.....	66
PRE-STRESS BRACE PLATES	37
PRO BARS & PRO BAR JUNIORS	56
PUSH-FIT CONES.....	10
PVC SHIMS	81

Q

QUICK BOLTS & NUTS	8
--------------------------	---

R

RAPID LOCK COLUMN CLAMP	29
REBAR CAPS.....	64
REBAR COVERS	64
REBAR GUARDS, PLASTIC.....	64
REBAR SADDLES	34
REBAR SCREED HOLDERS, #4.....	29
REELS.....	63
RESHORE SPRINGS.....	84
ROD CLAMPS.....	58
ROUND STAKES	27

S

S PANEL LOOP TIES	55
SAFETY RAIL BRACKETS	53
SCAFFOLD BRACKETS W/ WALER HOOK.....	50
SCAFFOLD BRACKETS.....	49
SCAFFOLD JACKS.....	49
SCHOOL BRACKETS.....	25
SCISSOR CLAMPS	24
SCREED CHAIR BASES	33
SCREED CHAIR BASES, HEAVY DUTY	34
SCREED HOLDERS, HEAVY DUTY	34
SCREED HOOKS, DOUBLE.....	29
SCREED HOOKS, FLAT STAKE.....	30
SCREED HOOKS, ROUND HOLE.....	29
SCREED HOOKS, SQUARE HOLE.....	29
SCREED HOOKS, WIRE	30
SCREED PAD POSTS	31
SCREED PADS.....	31
SCREW JACKS	83
SCREW POINT POSTS.....	32
SCREW-ON PLASTIC CONES.....	61
SET-BACK PLUGS	67
SETTING PLUGS.....	67
SHE BOLT PULLERS	6
SHE BOLTS	3
SHIM PACKS	81
SHIMS	81
SHORE CLAMPS.....	82
SHORE JACKS	82
SILVER DOLLARS.....	57
SINGLE LIFTING PLATES.....	78
SINGLE LINER SCAFFOLD JACKS.....	49
SKIP BOXES.....	37
SLAB GRABBERS	53
SMOOTH DOWELS	61
SNAP BRACKETS.....	51
SNAP JACKS.....	51
SNAPTIE EXTENDERS.....	46
SNAPTIE PLUGS.....	56
SNAPTIE SPACING CHART	39

INDEX

SNAPTIE WEDGES.....	46
SNAPTIE WRENCHES.....	44
SNAPTIES.....	38-42
SNAPTIES, THREADED.....	42
SNAPTIES, TIP TO TIP.....	42
SNAPTIES, WATERSEAL.....	42
SPANDREL HOOK SNAPTIES.....	42
SPANDREL PLATE SNAPTIES.....	42
SPANDREL POINT SNAPTIES.....	42
SPEC CAP.....	64
SPECIAL PLATES.....	37
SPEED BOLTS & NUTS.....	8
SPEED SCREEDS.....	26
SPLICE BARS.....	62
SQUARE STAKES.....	28
STAKE PULLERS.....	30
STAKES, FLAT.....	28
STAKES, ROUND.....	27
STAKES, SQUARE.....	27
STAR INSERTS.....	66
STEEL CHAMFER.....	48
STEEL REBAR TROUGH.....	64
STEEL RIB.....	18
STEEL RIB TIE.....	18
STEEL STRONGBACKS.....	36
STRAIGHT COIL LOOP INSERTS.....	73
STRAIGHT FERRULE LOOP INSERTS.....	69
STRIPPING BARS.....	56
SUPER HIGH STRENGTH TAPER TIES.....	2
SUPER HIGH STRENGTH SHE BOLTS.....	4
SUPER OVERHANG BRACKETS, 10K.....	23
SUPER TILT-UP BRACES.....	79
SWING LOCKS.....	37
SWIVEL OVERHANG BRACKETS.....	21
SWIVEL WING NUTS, EURO.....	16

T

TAPER TIES.....	1-2
TAPPED LAG BOLTS.....	9
THIN SLAB INSERTS.....	70,75
THREAD CHASERS.....	10
THREADED INSERTS.....	67-75
THREADED KEYPLATES.....	5
THREADED PLASTIC PLUGS.....	67
TIE EXTENDERS.....	46
TIE WIRE REELS.....	63
TIGHTENING WRENCHES.....	58
TILT-UP ANGLE CLIPS.....	84
TILT-UP BRACE COUPLERS.....	80
TILT-UP BRACE L-PINS.....	80
TILT-UP BRACE PARTS.....	80
TILT-UP BRACES, D-12 HEAVY DUTY.....	79

TILT-UP BRACES, D-8 SUPER.....	79
TILT-UP BRACES: D-1, D-4, D-5.....	79
TURNBUCKLES.....	54

U

USS WASHERS.....	9
------------------	---

V

VINES WALER BRACKETS.....	52
---------------------------	----

W

WALER BOLT ASSEMBLIES.....	13
WALER BRACKETS, 2X4 & 2X6.....	52
WALER RODS.....	3
WALERS.....	36
WALKWAY BRACKETS.....	36,37
WALL BRACES.....	80
WALL PANEL SCAFFOLD BRACKETS.....	36
WALL PLATE ASSEMBLIES.....	22
WALL SPREADERS.....	54
WASHERS, BATTER.....	6
WASHERS, CUT.....	9
WASHERS, FLAT.....	6
WASHERS, PLATE.....	6
WATERSEALS.....	9
WEDGE BOLTS.....	45
WEDGE FORM TIES.....	43
WEDGE FORM TIES WEDGE.....	43
WEDGES.....	43
WELDED ANGLE BRACKETS.....	7
WELDING COIL TIES.....	59,60
WING NUTS, COIL.....	5
WING NUTS, EURO.....	16
WIRE SCREED HOOKS.....	30
WOOD STAKES.....	28
WRENCHES, ROD TIGHTENING.....	58
WRENCHES, SNAPTIE.....	44

X

X-FLAT TIES.....	55
------------------	----

ASTM Standard Reinforcing Bars

BAR SIZE DESIGNATION	WEIGHT POUNDS PER FOOT	NOMINAL DIMENSIONS-ROUND SECTIONS		
		DIAMETER-INCHES	CROSS SECT. AREA SQ. INCHES	PERIMETER INCHES
#3	.376	.375	.11	1.178
#4	.668	.500	.20	1.571
#5	1.043	.625	.31	1.963
#6	1.502	.750	.44	2.356
#7	2.044	.875	.60	2.749
#8	2.670	1.000	.79	3.142
#9	3.400	1.128	1.00	3.544
#10	4.303	1.270	1.27	3.990
#11	5.313	1.410	1.56	4.430
#14	7.65	1.693	2.25	5.32
#18	13.60	2.257	4.00	7.09

METRIC CONVERSIONS

LENGTH		AREA	
1 inch	= 25.40 millimeters	1 square inch	= 645.16 sq. millimeters
1 foot	= 30.48 centimeters	1 square inch	= 6.452 sq. centimeters
1 foot	= 304.8 millimeters	1 square foot	= 0.0929 sq. meters
1 foot	= 0.3048 meters	1 square yard	= 0.8361 sq. meters
1 yard	= 0.9144 meters		
1 mile	= 1.6093 kilometers	1 square millimeter	= 0.0016 sq. inches
		1 square centimeter	= 0.155 sq. inches
1 millimeter	= 0.0394 inches	1 square centimeter	= 0.0011 sq. feet
1 centimeter	= 0.3937 inches	1 square meter	= 10.7639 sq. feet
1 centimeter	= 0.0328 feet	1 square meter	= 1.1960 sq. yards
1 meter	= 1.0936 yards		
1 kilometer	= 0.6214 miles	1 cubic inch	= 16.3871 cu. centimeters
		1 cubic foot	= 0.0283 cu. meters
		1 cubic foot	= 0.7646 cu. meters
1 ounce	= 28.35 grams		
1 ounce	= 0.0283 kilograms	1 cubic millimeter	= 0.00006 cu inches
1 pound	= 0.4536 kilograms	1 cubic centimeter	= 0.0610 cu. inches
1 ton (2000 lbs.)	= 907.1847 kilograms	1 cubic meter	= 35.3148 cu. feet
		1 cubic meter	= 1.3080 cu. yards
1 gram	= 0.0353 ounces		
1 kilogram	= 2.2046 pounds		
1 metric ton	= 1.1023 tons		