

SPECTRUM CONCRETE PRODUCTS

The Best Choice for Concrete Accessories & Steel Fabrication

SPECTRUM'S CUSTOM FABRICATION & SPECIALTY PRODUCTS HANDBOOK

Adjustable Overhang Supports (Push-Pull Braces)
Anchor Bolt Templates
Angle Plate Covers
Approach Slab Anchors
Barrier Rail Forms
Beam Clips
Beam Ends (End Pans)
Bidwell Stands
Bidwell Pipe Holders & Bidwell Pipe w/Coupler
Bridge Overhang Brackets – 18” & 8-Kip w/Alt Bracket
Bulkhead Tie Plates
C-Clamps, Heavy Duty
C-Shape (A-DOT)
Capital Entry Forms
Caution Cone Holders
CIDH Cage Support Hangers
Closure Plates
Deck Retainer Assemblies
Double Channel Walers (Steel Strongbacks)
Edge of Deck Forms
Edge of Deck Safety Rail Brackets – Standard & Slipover
Embed Plates
Falsework Stripping Baskets

SPECTRUM CONCRETE PRODUCTS

The Best Choice for Concrete Accessories & Steel Fabrication

Flange Clips

Friction Collars

Gang Form Brace Brackets

Handrail Posts – Standard & Flat Plate

Haunch Brackets

K-Rail Stakes & Pins (Cal-Trans)

Kip Jacks

Lackey Brackets

Lifting Eyes/Pad Eyes

Longitudinal Bracing Plates (Pacmen)

Lost Deck Hangers – Full/Half/Sloped

LR Clips/Falsework Connectors

Material Bins

Picking Eye Plates

Plate Clips

Pre-Stress Brace Plates

Rapid-Lock Column Clamps

Retaining Wall Scaffold Brackets

Rumble Plates

Skip Boxes

Tower Crane Extensions

Trash Hoppers – Pivot Style

Wall Panel Scaffold Brackets

Wheel Chock Holders

Working Platform Brackets

Z-Brackets

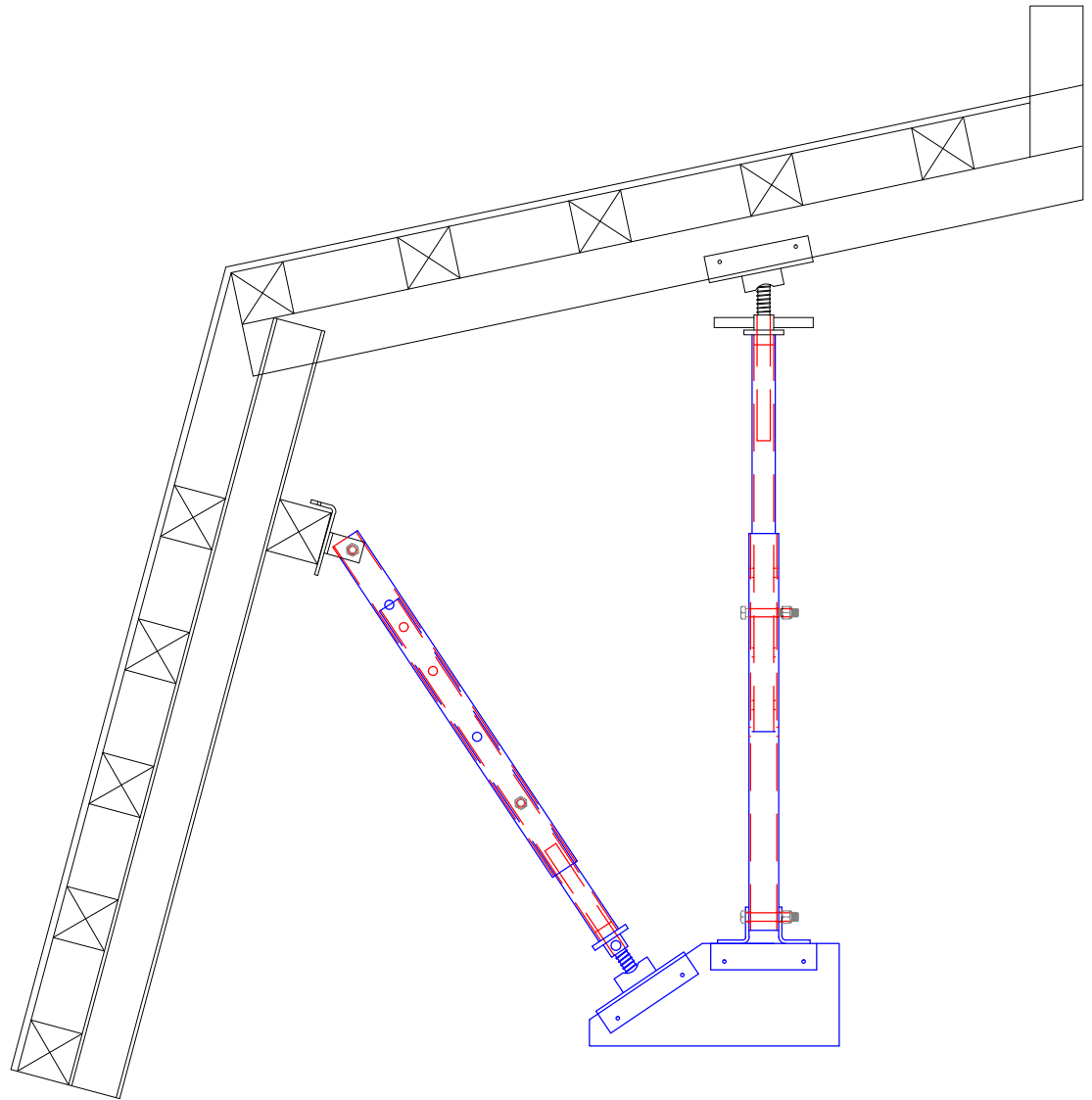
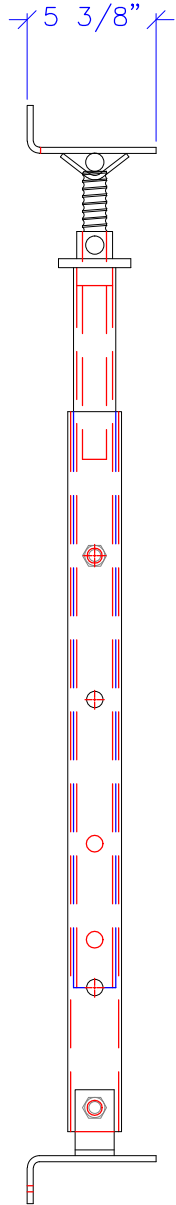
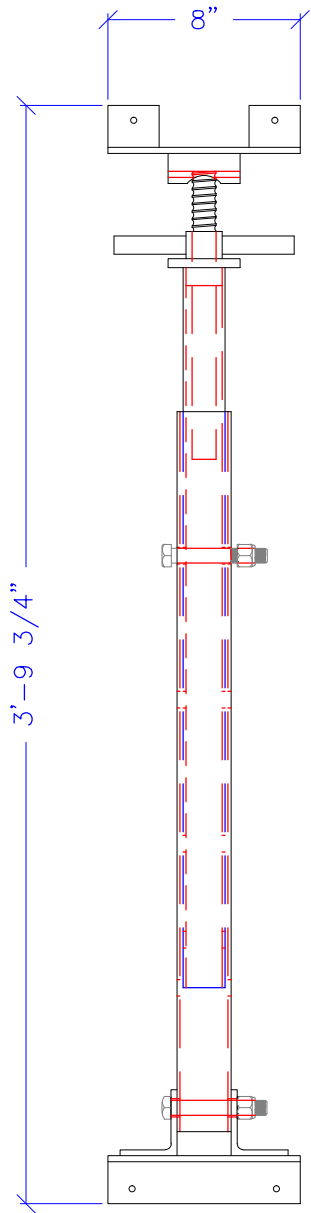

UNLESS OTHERWISE SPECIFIED DIM. ARE IN INCHES. TOLERANCES ARE: FRACTIONS: $\pm \frac{1}{16}$ " ANGLES: $\pm 1^\circ$	CONTRACT NO.		SPECTRUM CONCRETE PRODUCTS, LLC.	
	APPROVALS	DATE		
	DRAWN	00-00-00	TITLE:	ADJUSTABLE OVERHANG SUPPORT BRACKET
	CHECKED		SIZE	DWG NO.
MATERIAL	ISSUED		A	
			SCALE	SHEET

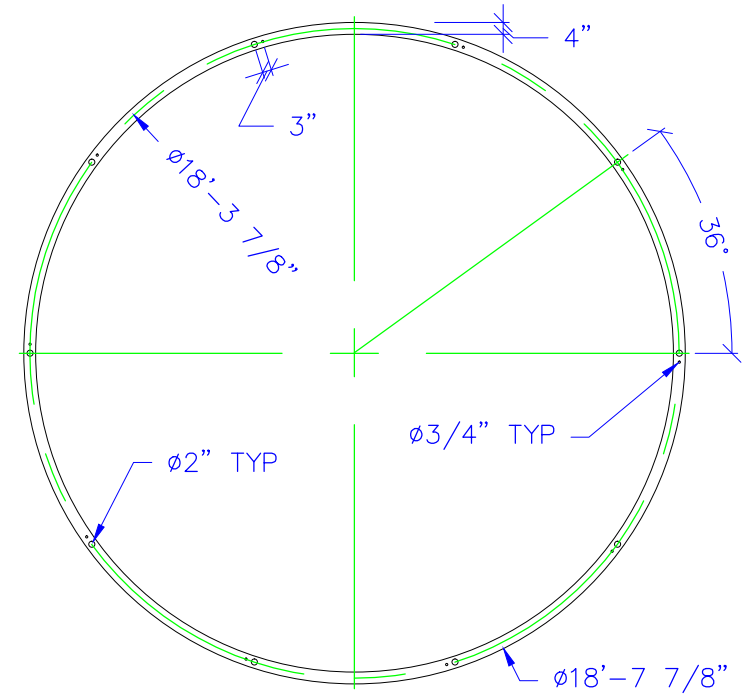
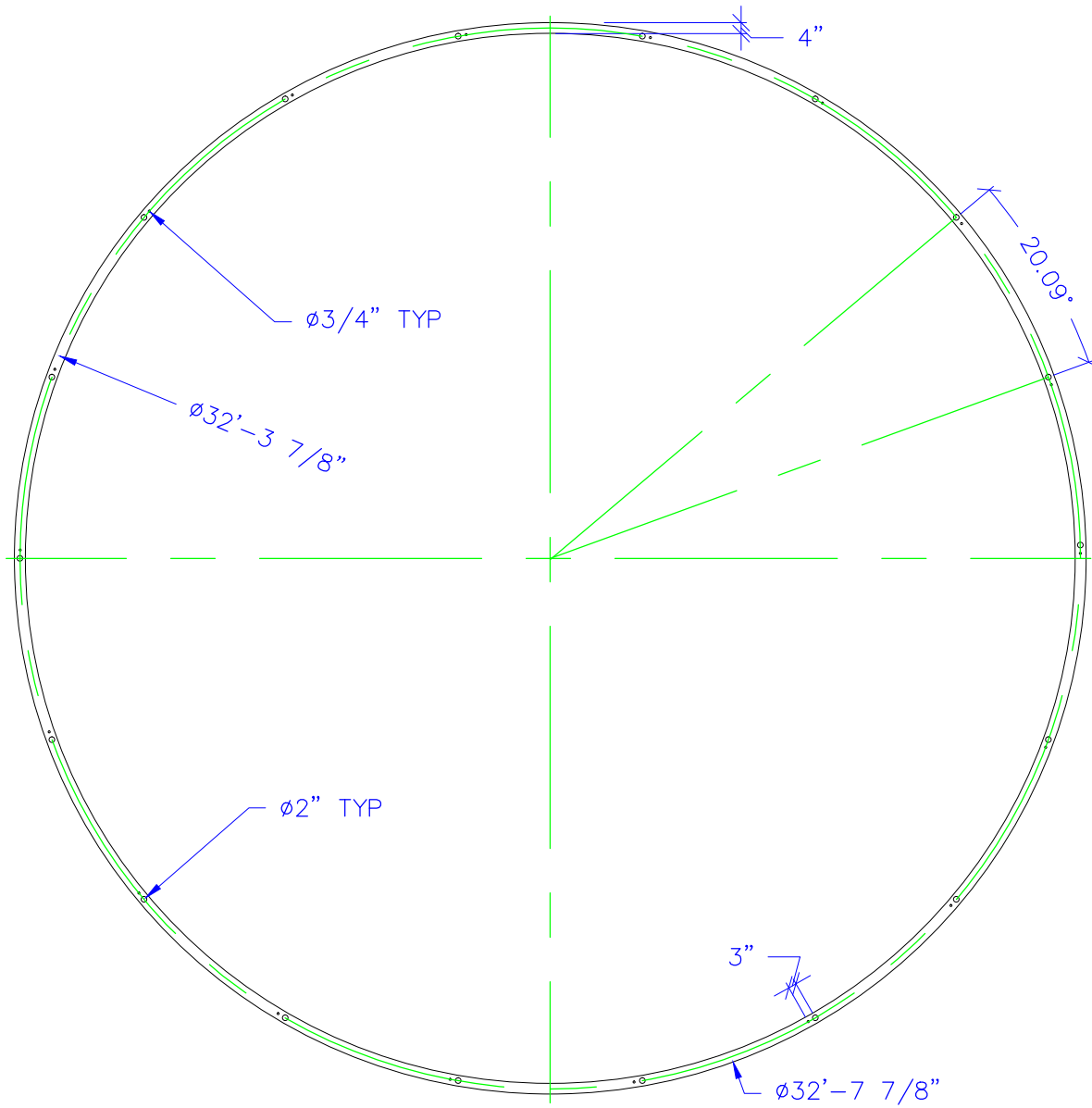

UNLESS OTHERWISE SPECIFIED DIM. ARE IN INCHES. TOLERANCES ARE: FRACTIONS: $\pm \frac{1}{8}$ " ANGLES: $\pm 1^\circ$	CONTRACT NO.		SPECTRUM CONCRETE PRODUCTS, LLC.	
	APPROVALS	DATE		
	DRAWN	00-00-00	TITLE: ANCHOR BOLT TEMPLATE	
	CHECKED		SIZE A	DWG NO.
MATERIAL	ISSUED		SCALE	SHEET

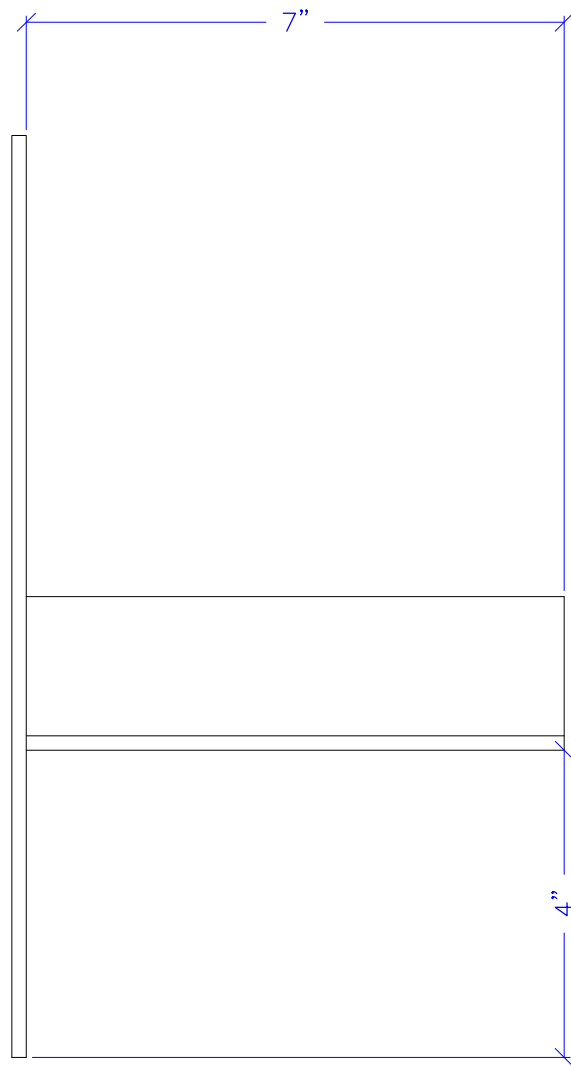
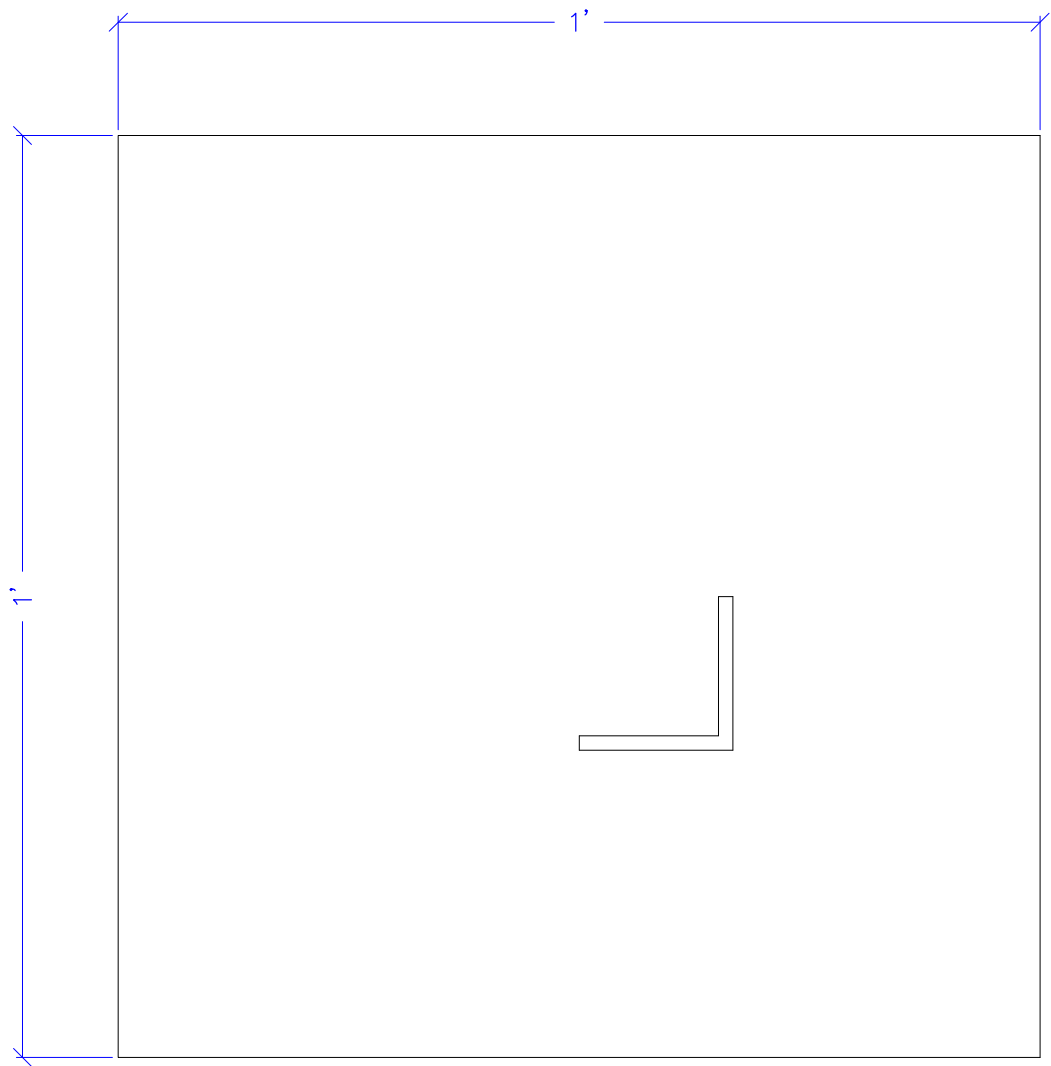

UNLESS OTHERWISE SPECIFIED DIM. ARE IN INCHES. TOLERANCES ARE: FRACTIONS: $\pm \frac{1}{16}$ " ANGLES: $\pm 1^\circ$	CONTRACT NO.		SPECTRUM CONCRETE PRODUCTS, LLC.	
	APPROVALS	DATE		
	DRAWN	00-00-00	TITLE:	ANGLE PLATE COVER
	CHECKED		SIZE	DWG NO.
MATERIAL	ISSUED		A	
			SCALE	SHEET

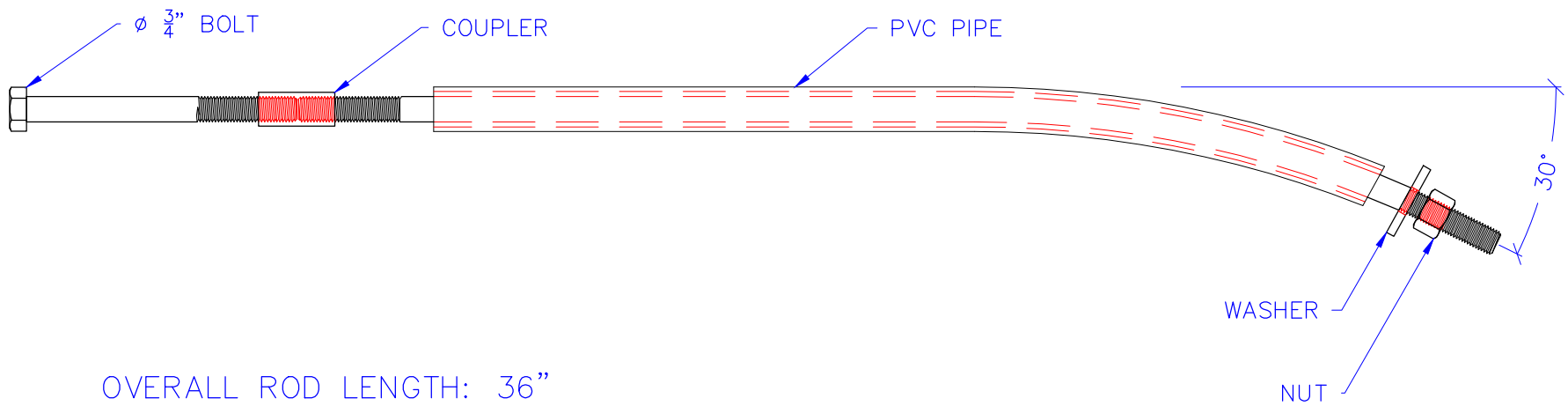

UNLESS OTHERWISE SPECIFIED DIM. ARE IN INCHES. TOLERANCES ARE: FRACTIONS: $\pm \frac{1}{16}$ " ANGLES: $\pm 1^\circ$	CONTRACT NO.		SPECTRUM CONCRETE PRODUCTS, LLC.	
	APPROVALS	DATE		
	DRAWN	00-00-00	TITLE:	APPROACH SLAB ANCHOR
	CHECKED		SIZE	DWG NO.
MATERIAL	ISSUED		A	
			SCALE	SHEET

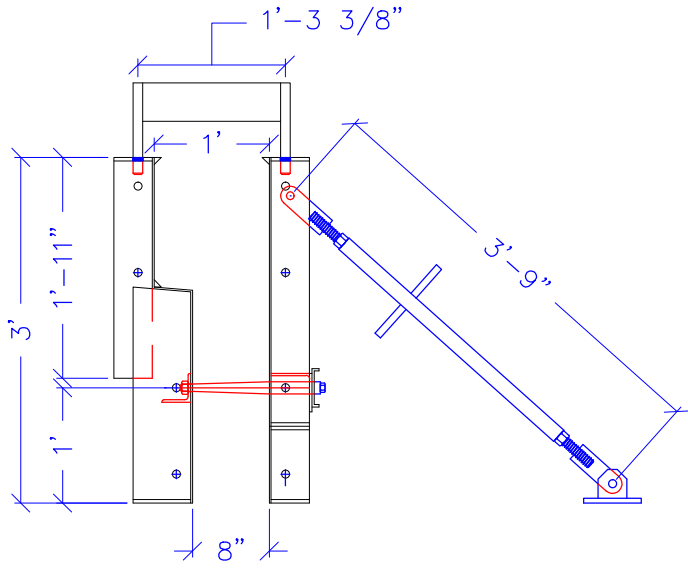

END ELEVATION

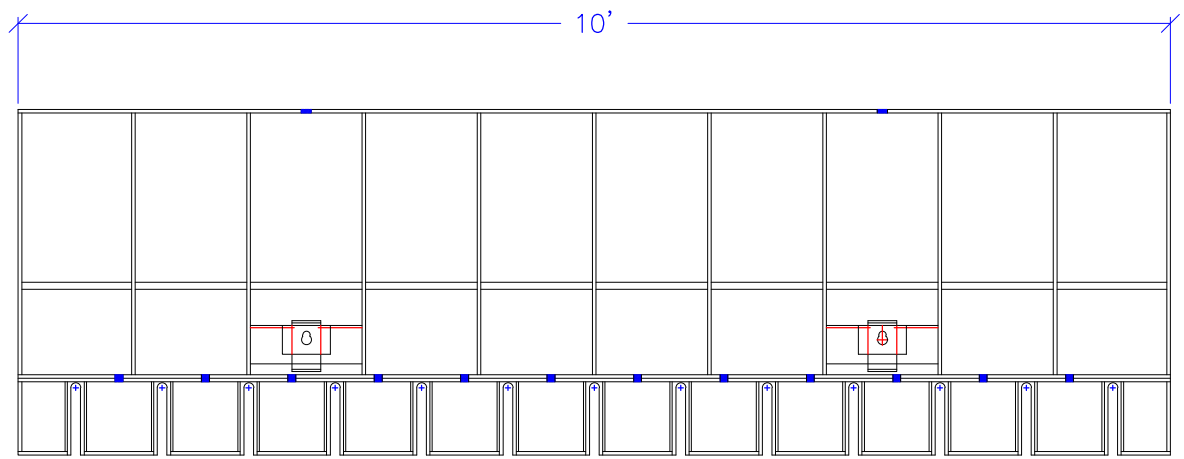

FRONT PANEL ELEVATION

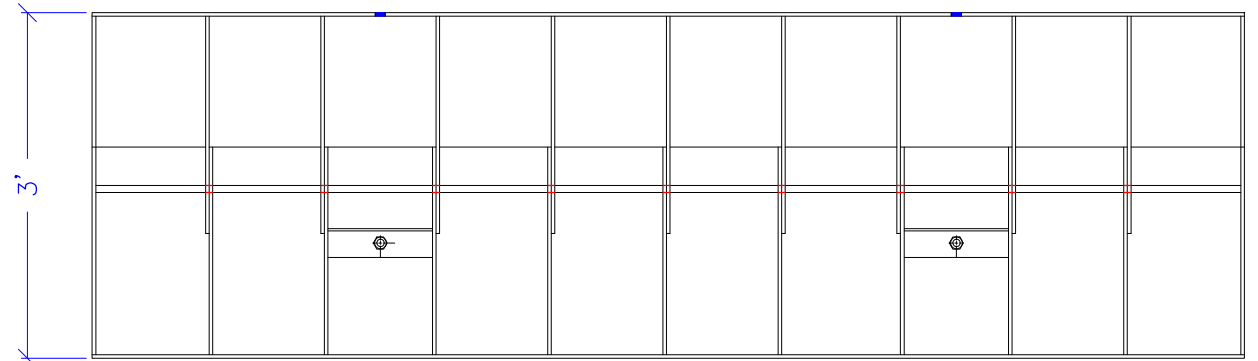

BACK PANEL ELEVATION

UNLESS OTHERWISE SPECIFIED DIM. ARE IN INCHES. TOLERANCES ARE: FRACTIONS: ± 1/16" ANGLES: ± 1°	CONTRACT NO.		SPECTRUM CONCRETE PRODUCTS, LLC.	
	APPROVALS	DATE		
	DRAWN	00-00-00	TITLE:	BARRIER RAIL FORM
	CHECKED		SIZE	
MATERIAL	ISSUED		A	REV.
			SCALE	SHEET

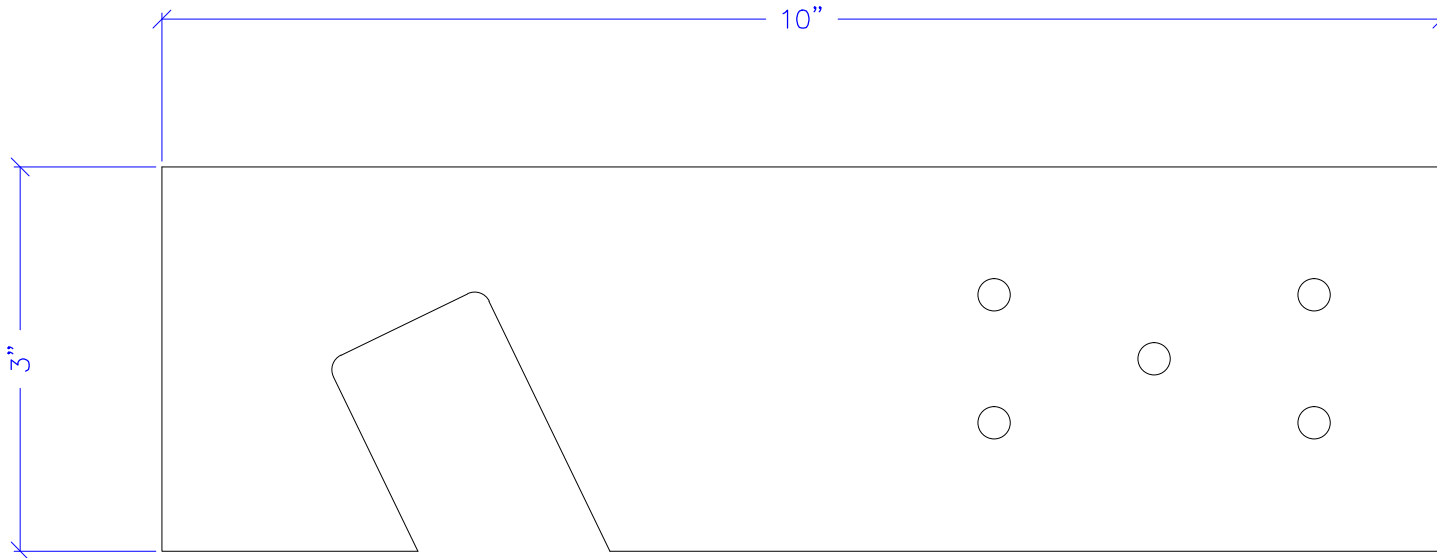

UNLESS OTHERWISE SPECIFIED DIM. ARE IN INCHES. TOLERANCES ARE: FRACTIONS: $\pm \frac{1}{16}$ " ANGLES: $\pm 1^\circ$	CONTRACT NO.		SPECTRUM CONCRETE PRODUCTS, LLC.		
	APPROVALS	DATE			
	DRAWN	00-00-00	TITLE:	BEAM CLIP	
	CHECKED				
MATERIAL	ISSUED		SIZE	DWG NO.	REV.
			A		
			SCALE	SHEET	

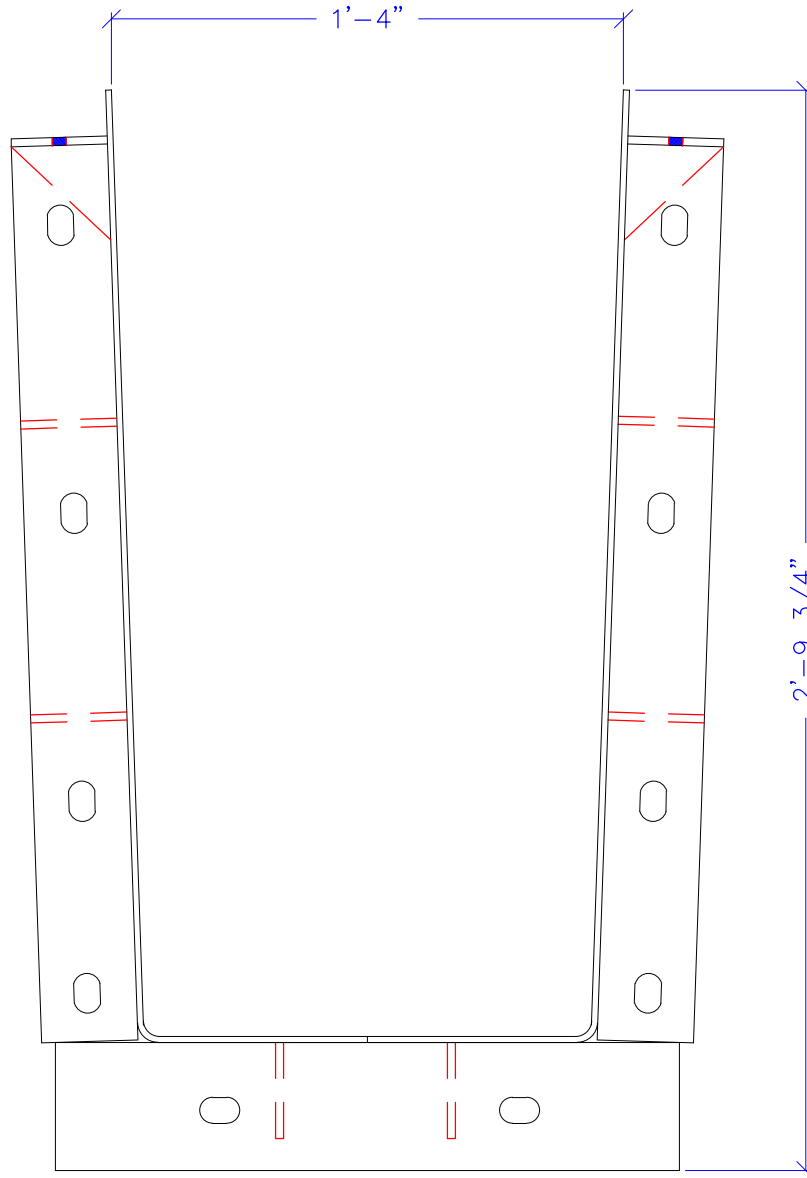
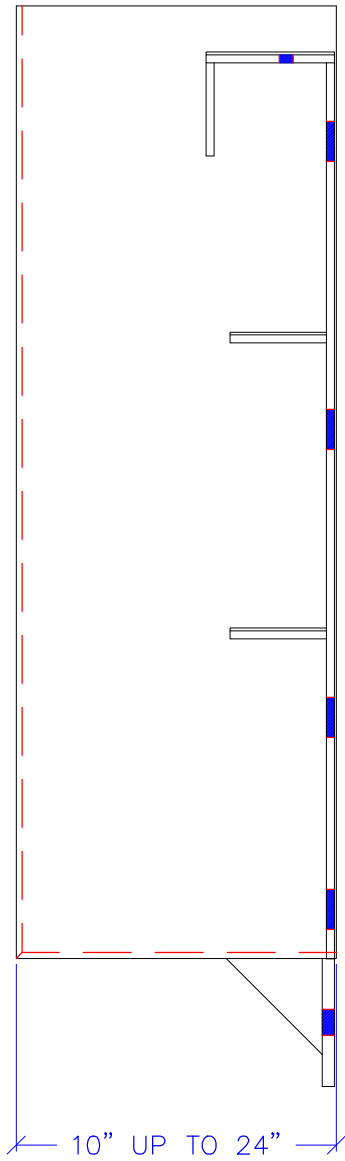

UNLESS OTHERWISE SPECIFIED DIM. ARE IN INCHES. TOLERANCES ARE: FRACTIONS: $\pm \frac{1}{16}$ " ANGLES: $\pm 1^\circ$	CONTRACT NO.		SPECTRUM CONCRETE PRODUCTS, LLC.	
	APPROVALS	DATE		
	DRAWN	00-00-00	BEAM END	
	CHECKED		SIZE	DWG NO.
MATERIAL	ISSUED		A	
			SCALE	SHEET

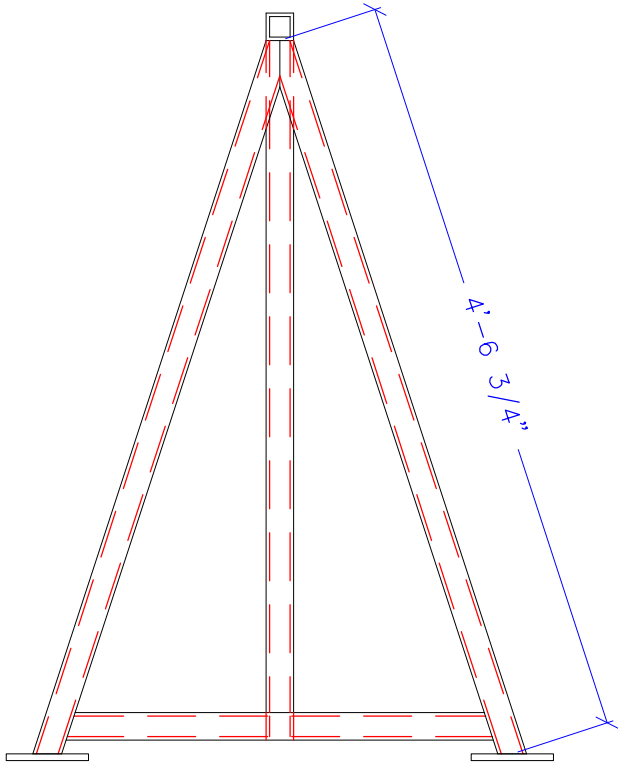

SIDE VIEW

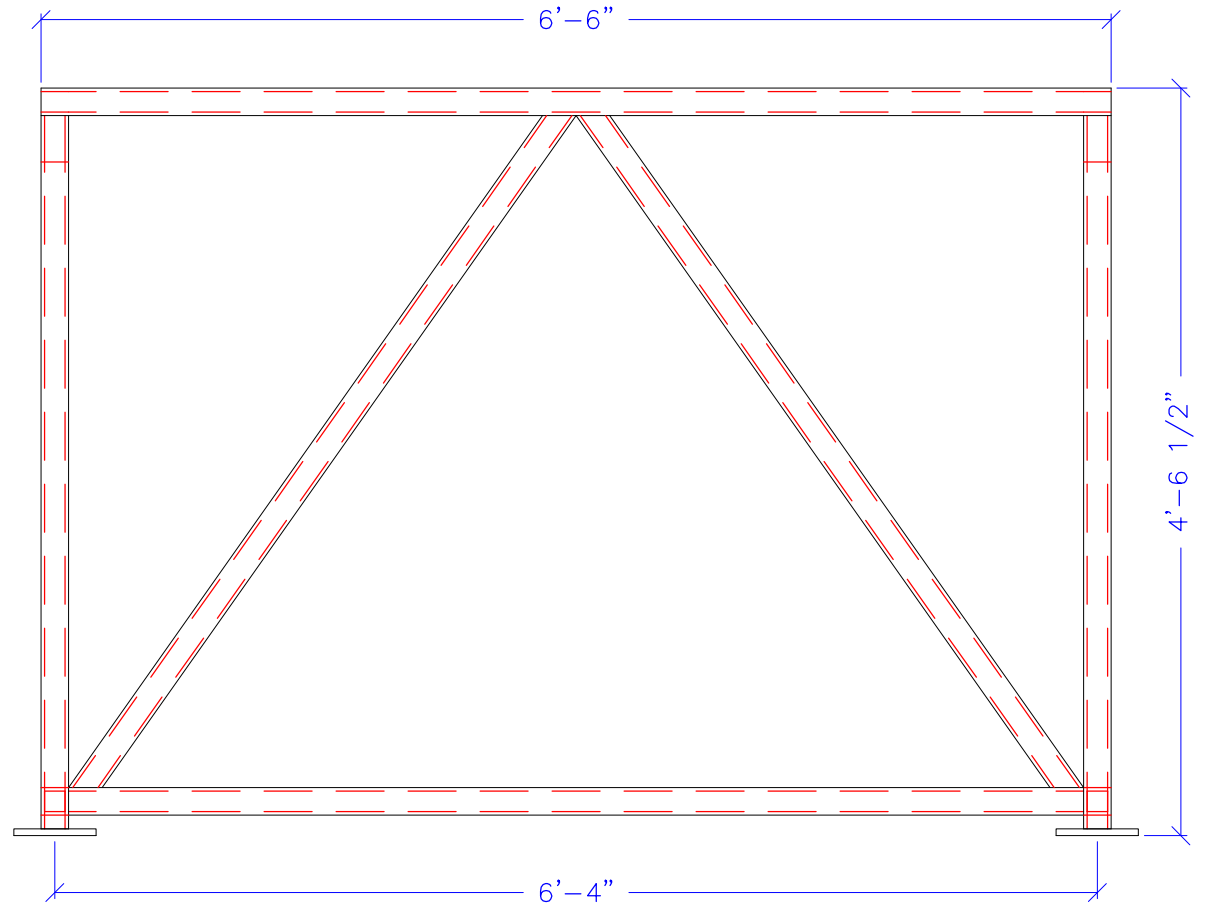

FRONT VIEW

UNLESS OTHERWISE SPECIFIED DIM. ARE IN INCHES. TOLERANCES ARE: FRACTIONS: $\pm \frac{1}{16}"$ ANGLES: $\pm 1^\circ$	CONTRACT NO.		SPECTRUM CONCRETE PRODUCTS, LLC.	
	APPROVALS	DATE		
	DRAWN	00-00-00	TITLE:	BIDWELL STAND
	CHECKED		SIZE	
MATERIAL	ISSUED		A	REV.
			SCALE	SHEET

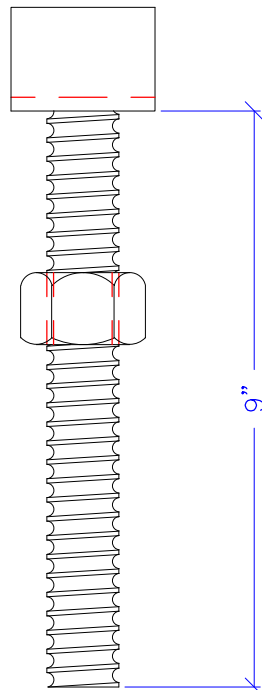
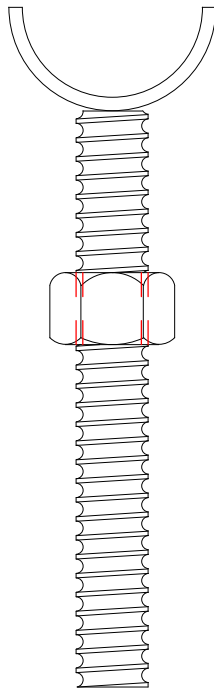
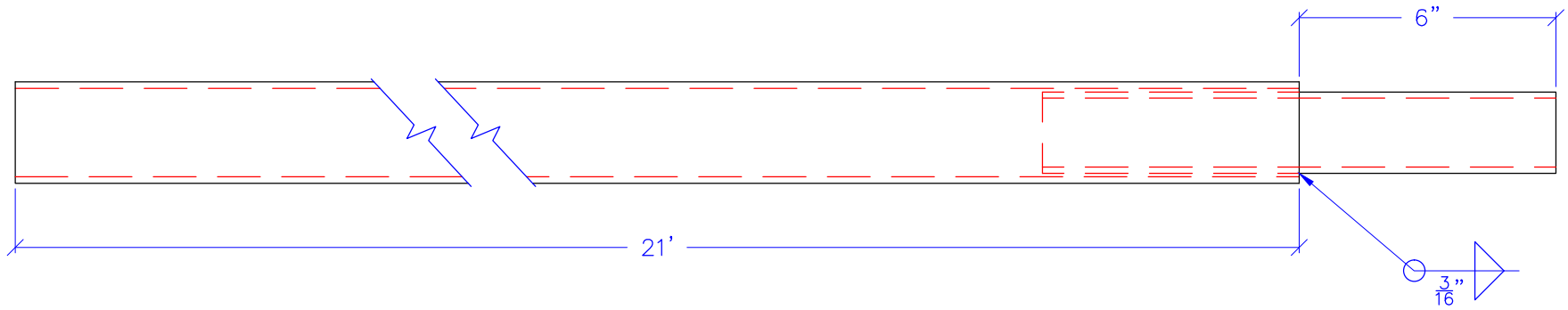

UNLESS OTHERWISE SPECIFIED DIM. ARE IN INCHES. TOLERANCES ARE: FRACTIONS: $\pm \frac{1}{16}$ " ANGLES: $\pm 1^\circ$	CONTRACT NO.		SPECTRUM CONCRETE PRODUCTS, LLC.
	APPROVALS	DATE	
	DRAWN	00-00-00	TITLE: 2 1/2" SCREED PIPE WITH WELDED COUPLER & 1" Ø HEAVY DUTY SCREED HOLDER
	CHECKED		SIZE: A
MATERIAL	ISSUED		REV.
		SCALE	SHEET

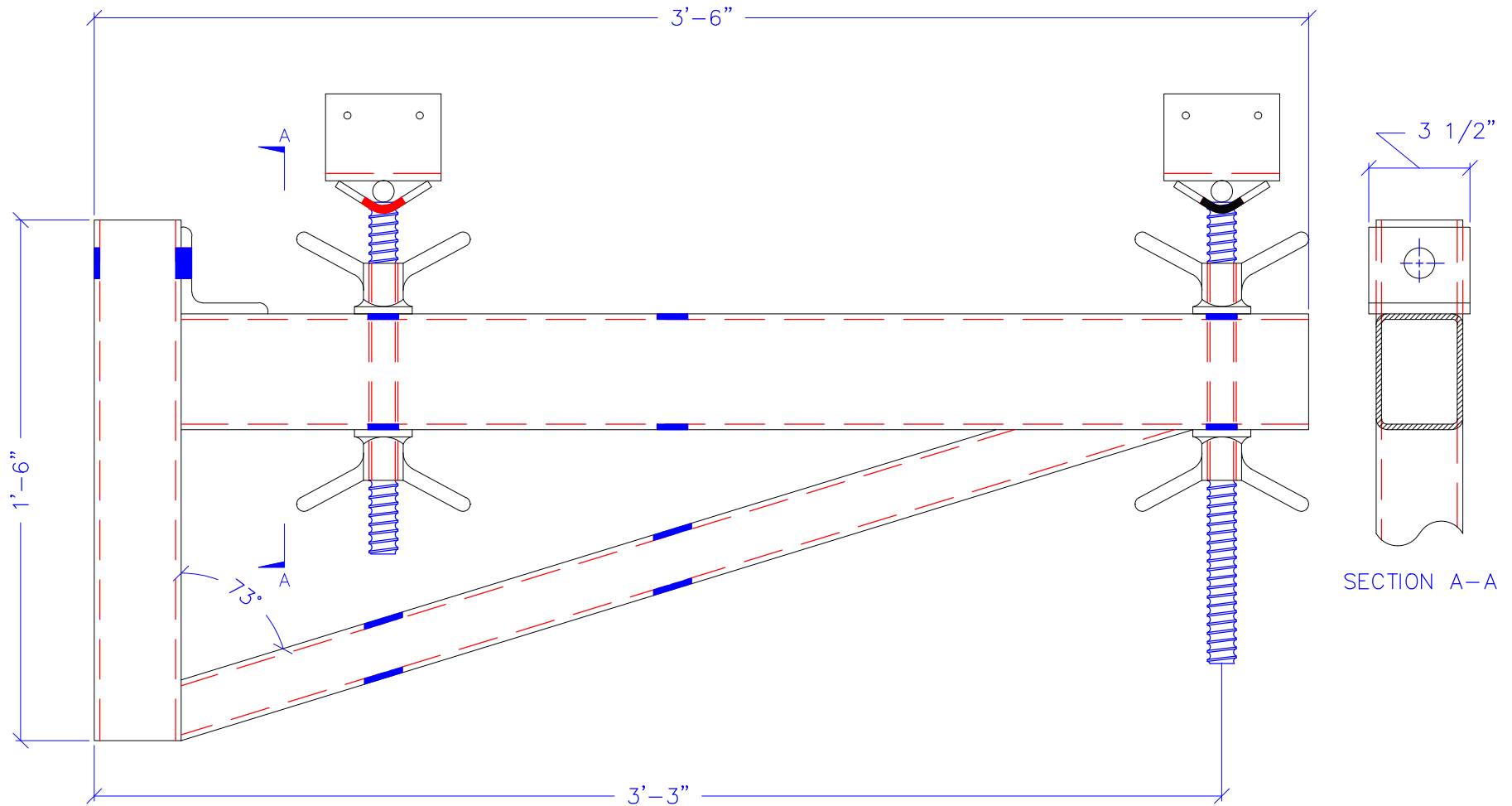

SECTION A-A

OTHER STYLES AVAILABLE UPON REQUEST

UNLESS OTHERWISE SPECIFIED DIM. ARE IN INCHES. TOLERANCES ARE: FRACTIONS: $\pm \frac{1}{16}$ " ANGLES: $\pm 1^\circ$	CONTRACT NO.		SPECTRUM CONCRETE PRODUCTS, LLC. TITLE: 18" BRIDGE OVERHANG BRACKET
	APPROVALS	DATE	
	DRAWN	00-00-00	
	CHECKED		
MATERIAL	ISSUED		SIZE A DWG NO. REV.
			SCALE SHEET

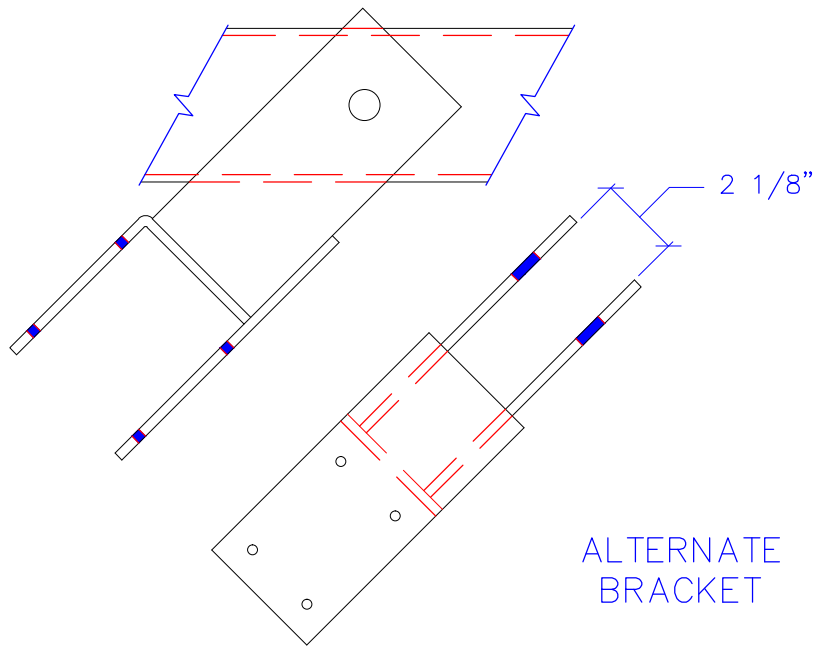
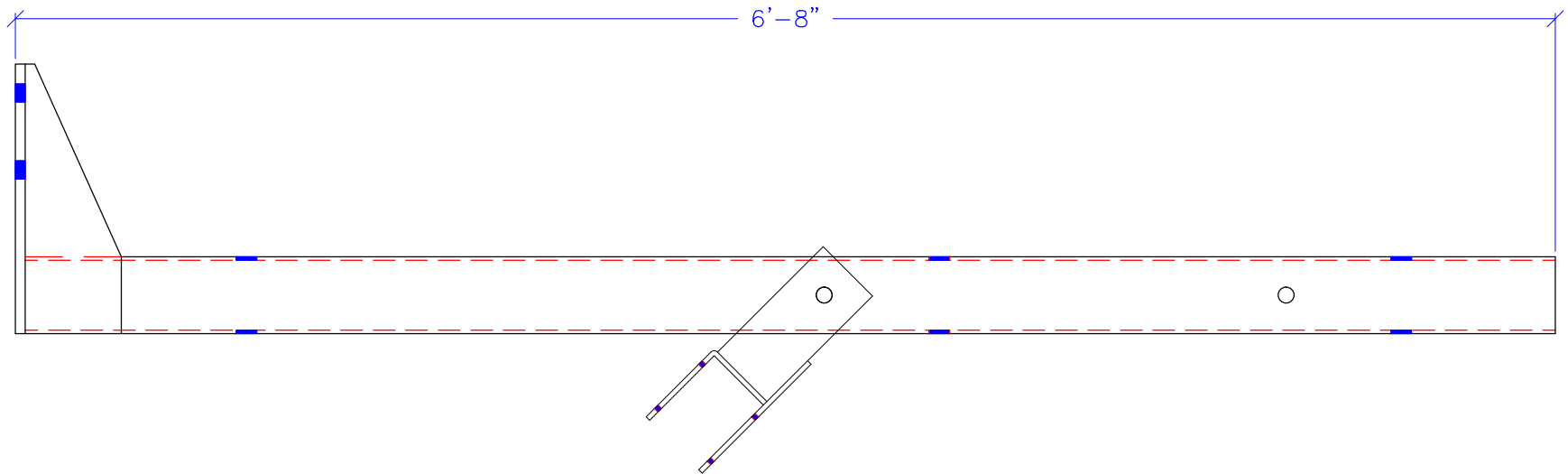

UNLESS OTHERWISE SPECIFIED DIM. ARE IN INCHES. TOLERANCES ARE: FRACTIONS: $\pm \frac{1}{8}$ " ANGLES: $\pm 1^\circ$	CONTRACT NO.		SPECTRUM CONCRETE PRODUCTS, LLC.	
	APPROVALS	DATE		
	DRAWN	00-00-00	TITLE: 8 KIP OVERHANG BRACKET & ALTERNATE BRACKET	
	CHECKED		SIZE: A	DWG NO.
MATERIAL	ISSUED		SCALE	SHEET

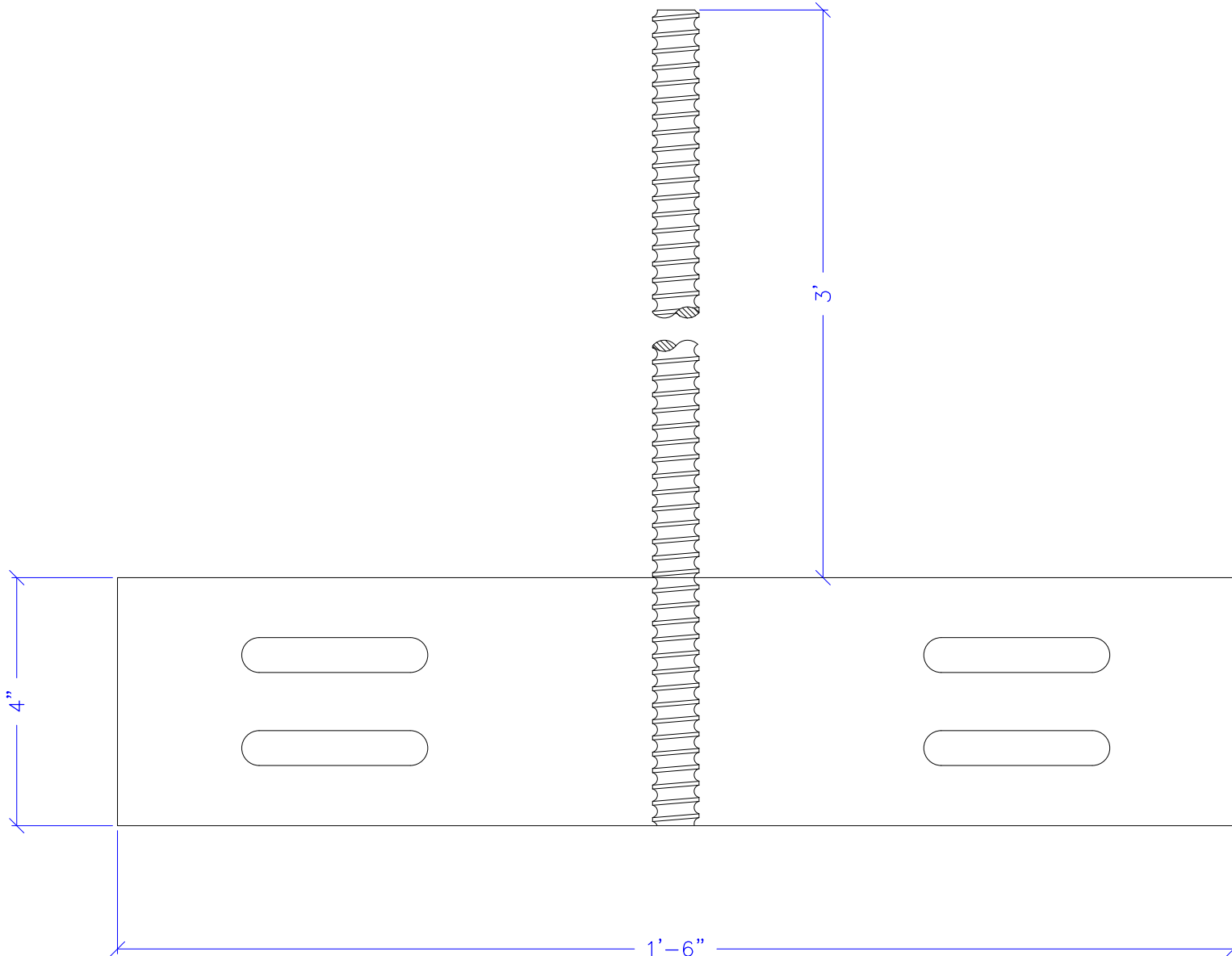

UNLESS OTHERWISE SPECIFIED DIM. ARE IN INCHES. TOLERANCES ARE: FRACTIONS: $\pm \frac{1}{16}$ " ANGLES: $\pm 1^\circ$	CONTRACT NO.		SPECTRUM CONCRETE PRODUCTS, LLC.	
	APPROVALS	DATE		
	DRAWN	00-00-00	TITLE:	BULKHEAD TIE PLATE
	CHECKED		SIZE	DWG NO.
MATERIAL	ISSUED		A	
			SCALE	SHEET

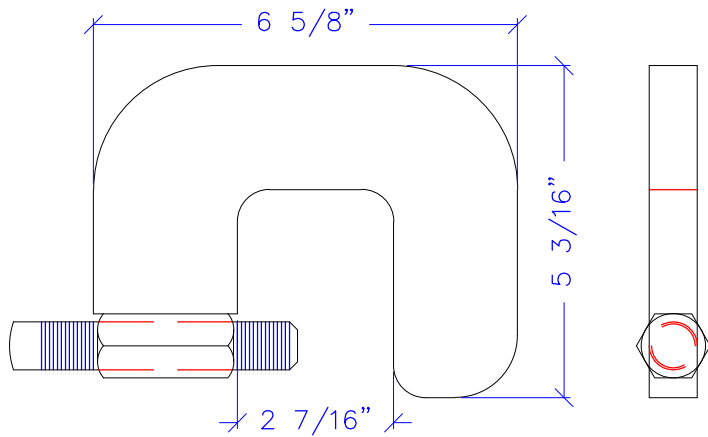

STANDARD HD C-CLAMP

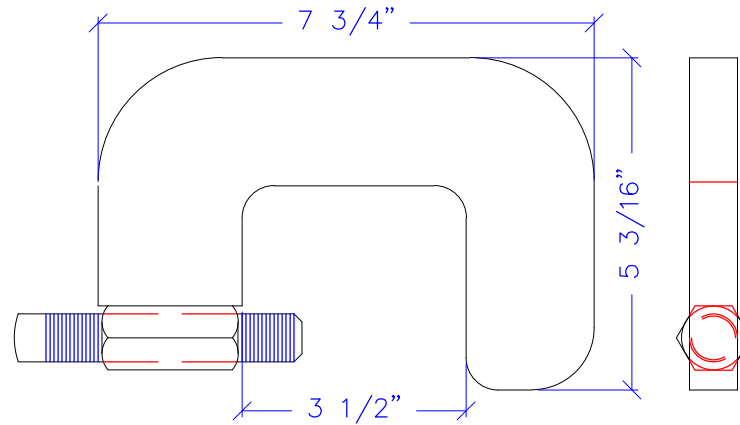

3 1/2" OPENING C-CLAMP

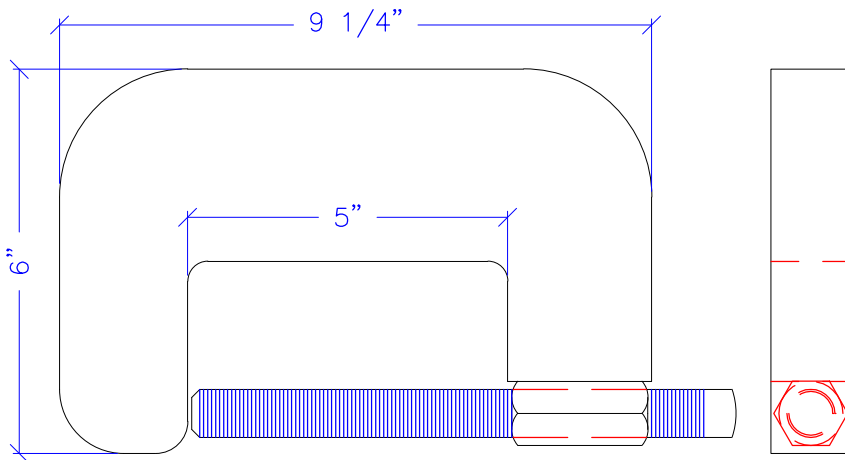

SPECIAL HD C-CLAMP

OTHER OPENINGS AVAILABLE UPON REQUEST

UNLESS OTHERWISE SPECIFIED DIM. ARE IN INCHES. TOLERANCES ARE: FRACTIONS: $\pm \frac{1}{16}$ " ANGLES: $\pm 1^\circ$	CONTRACT NO.		SPECTRUM CONCRETE PRODUCTS, LLC.	
	APPROVALS	DATE		
	DRAWN	00-00-00	TITLE:	HEAVY DUTY C-CLAMPS
	CHECKED		SIZE	DWG NO.
MATERIAL	ISSUED		A	
			SCALE	SHEET

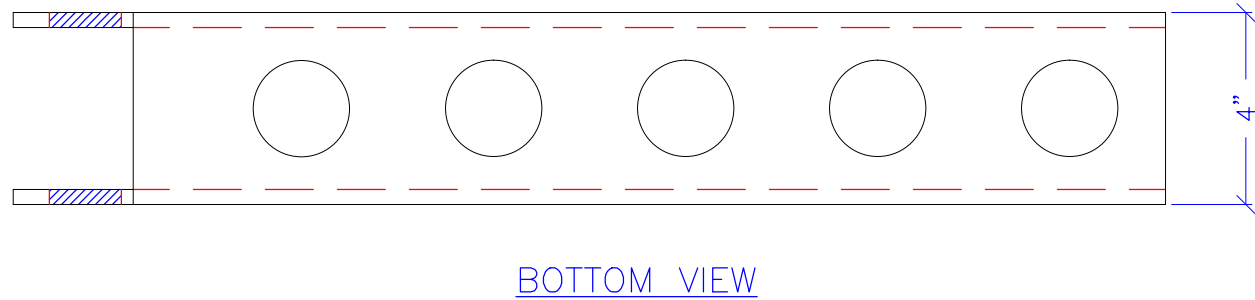
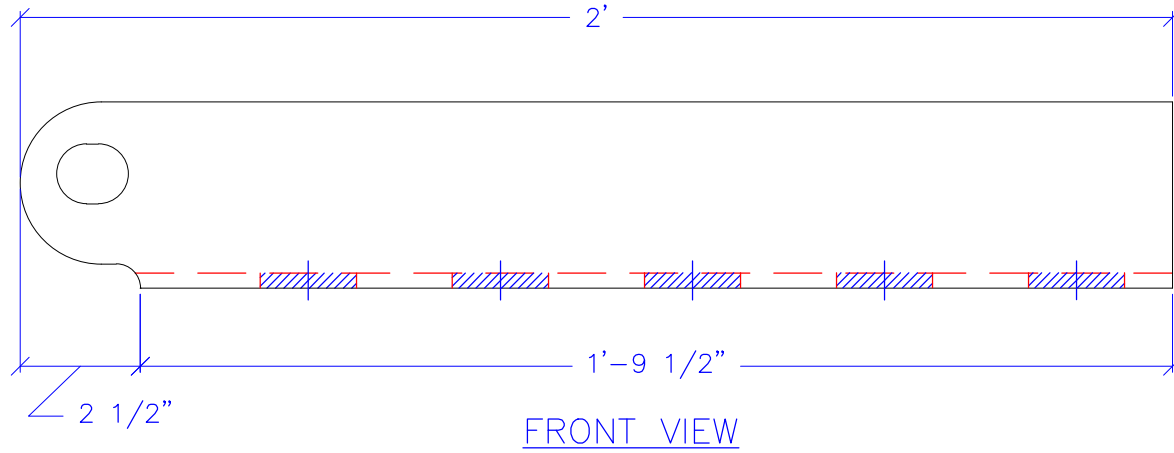
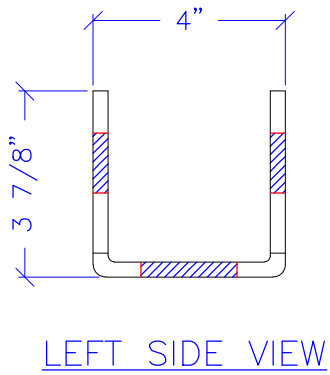

HOT DIPPED GALVANIZED ASTM 123

UNLESS OTHERWISE SPECIFIED DIM. ARE IN INCHES. TOLERANCES ARE: FRACTIONS: $\pm \frac{1}{16}$ " ANGLES: $\pm 1^\circ$	CONTRACT NO.		SPECTRUM CONCRETE PRODUCTS, LLC.		
	APPROVALS	DATE			
	DRAWN	00-00-00	TITLE:	A-DOT C-SHAPE	
	CHECKED		SCALE		
MATERIAL	ISSUED		SIZE A	DWG NO.	REV.
					SHEET

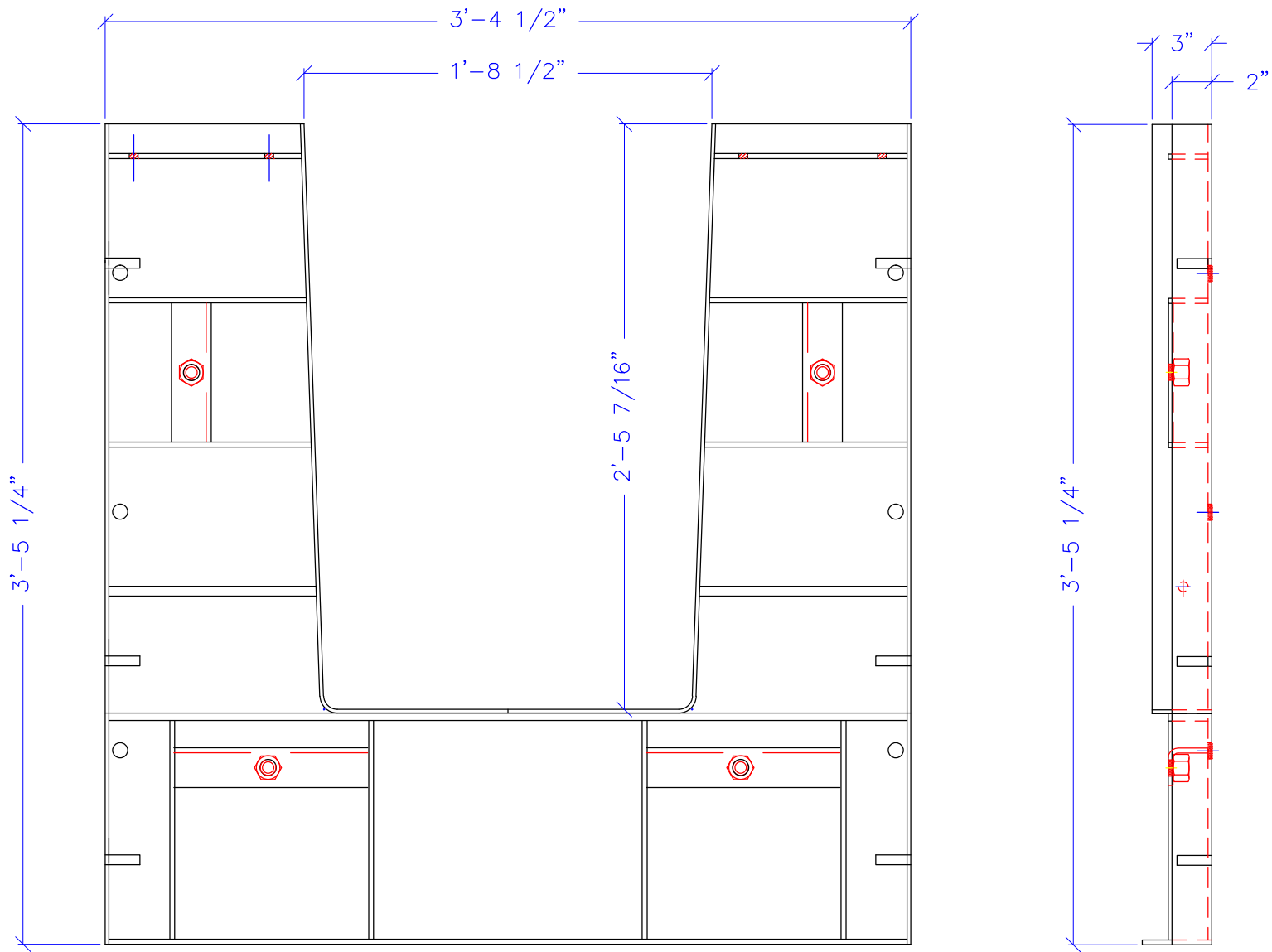

UNLESS OTHERWISE SPECIFIED DIM. ARE IN INCHES. TOLERANCES ARE: FRACTIONS: $\pm \frac{1}{16}$ " ANGLES: $\pm 1^\circ$	CONTRACT NO.		SPECTRUM CONCRETE PRODUCTS, LLC.	
	APPROVALS	DATE		
	DRAWN	00-00-00	TITLE:	CAPITAL ENTRY FORM
	CHECKED		SIZE	DWG NO.
MATERIAL	ISSUED		A	
			SCALE	SHEET

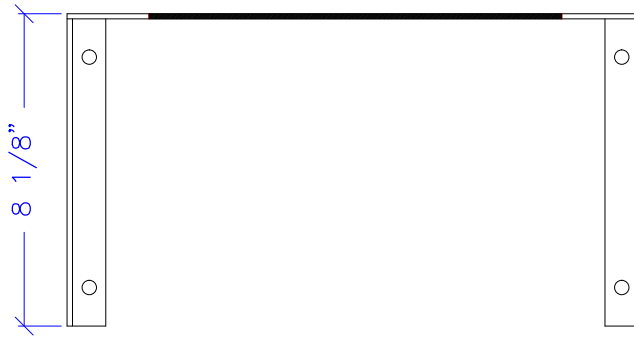
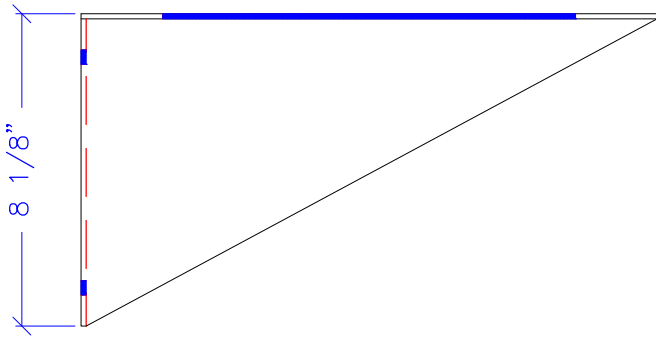
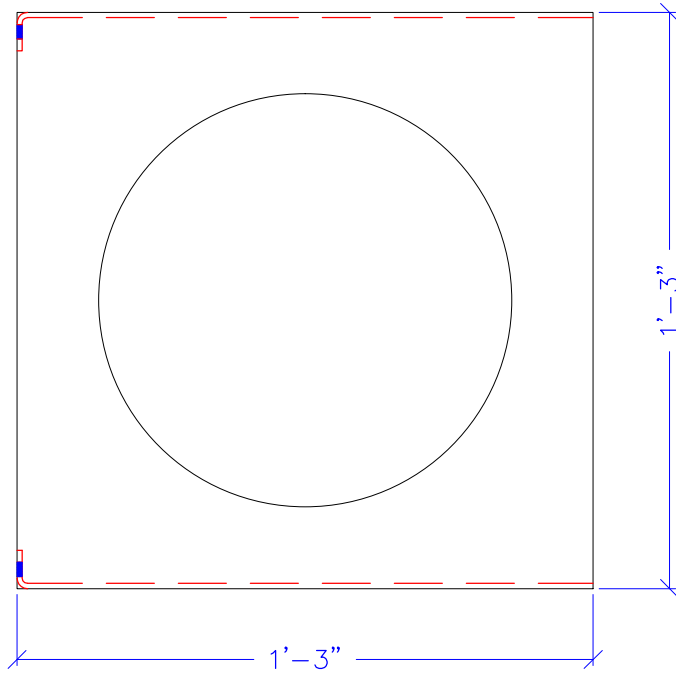

UNLESS OTHERWISE SPECIFIED DIM. ARE IN INCHES. TOLERANCES ARE: FRACTIONS: $\pm \frac{1}{16}$ " ANGLES: $\pm 1^\circ$	CONTRACT NO.		SPECTRUM CONCRETE PRODUCTS, LLC.	
	APPROVALS	DATE		
	DRAWN	00-00-00	TITLE:	CAUTION CONE HOLDER
	CHECKED		SIZE	DWG NO.
MATERIAL	ISSUED		A	
			SCALE	SHEET

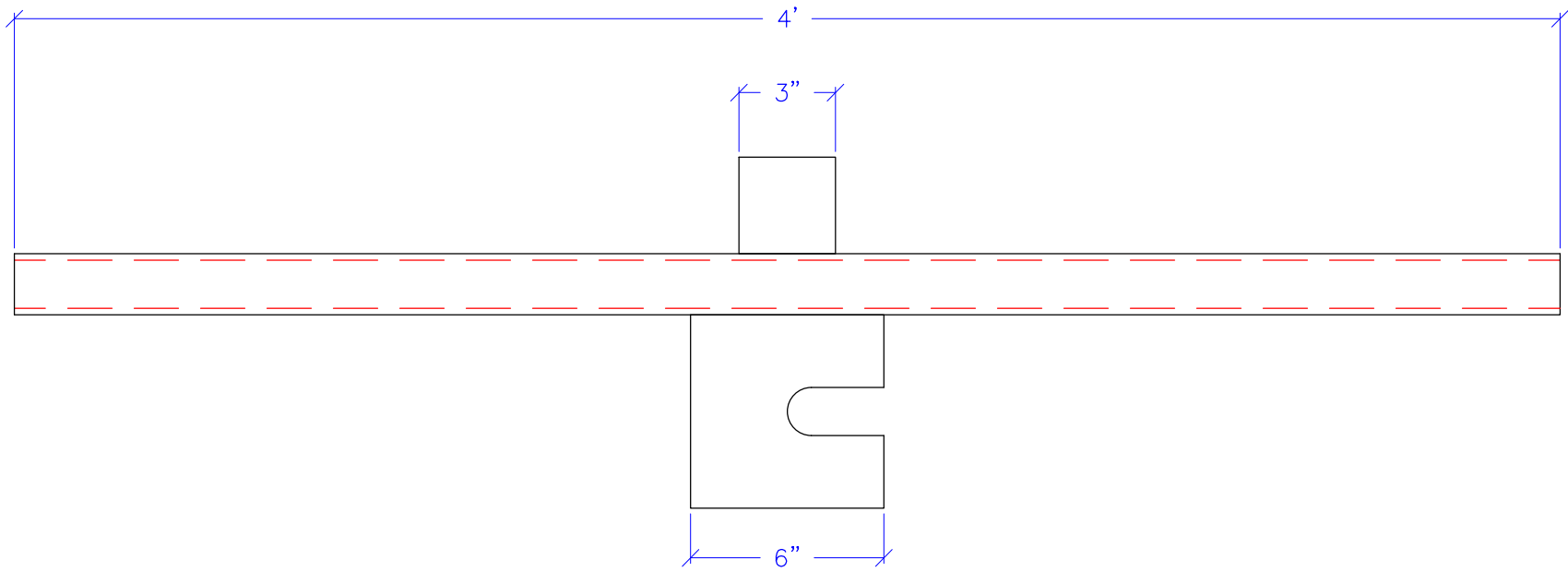

UNLESS OTHERWISE SPECIFIED DIM. ARE IN INCHES. TOLERANCES ARE: FRACTIONS: $\pm \frac{1}{16}$ " ANGLES: $\pm 1^\circ$	CONTRACT NO.		SPECTRUM CONCRETE PRODUCTS, LLC.	
	APPROVALS	DATE		
	DRAWN	00-00-00	TITLE: CIDH SUPPORT HANGER	
	CHECKED		SIZE A	DWG NO.
MATERIAL	ISSUED		SCALE	SHEET

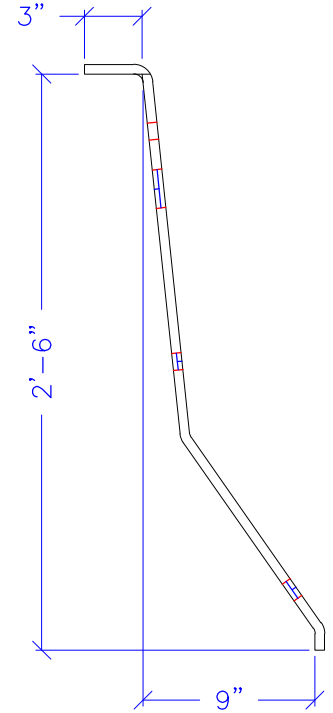
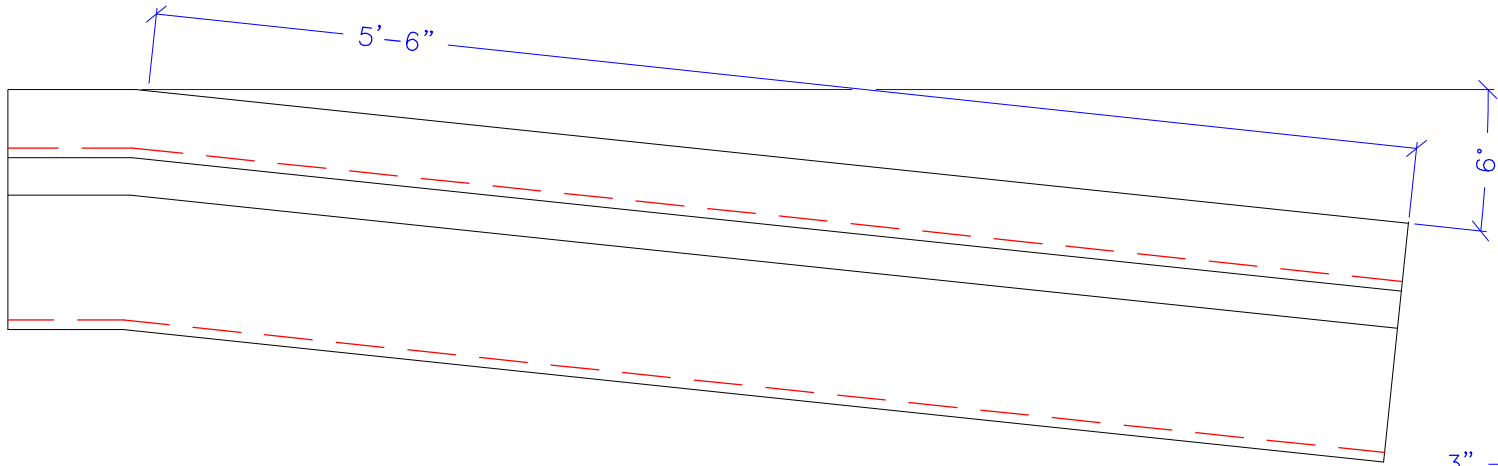

UNLESS OTHERWISE SPECIFIED DIM. ARE IN INCHES. TOLERANCES ARE: FRACTIONS: $\pm \frac{1}{16}$ " ANGLES: $\pm 1^\circ$	CONTRACT NO.		SPECTRUM CONCRETE PRODUCTS, LLC.	
	APPROVALS	DATE		
	DRAWN	00-00-00	TITLE:	CLOSURE PLATE
	CHECKED		SIZE	
MATERIAL	ISSUED		A	REV.
			SCALE	SHEET

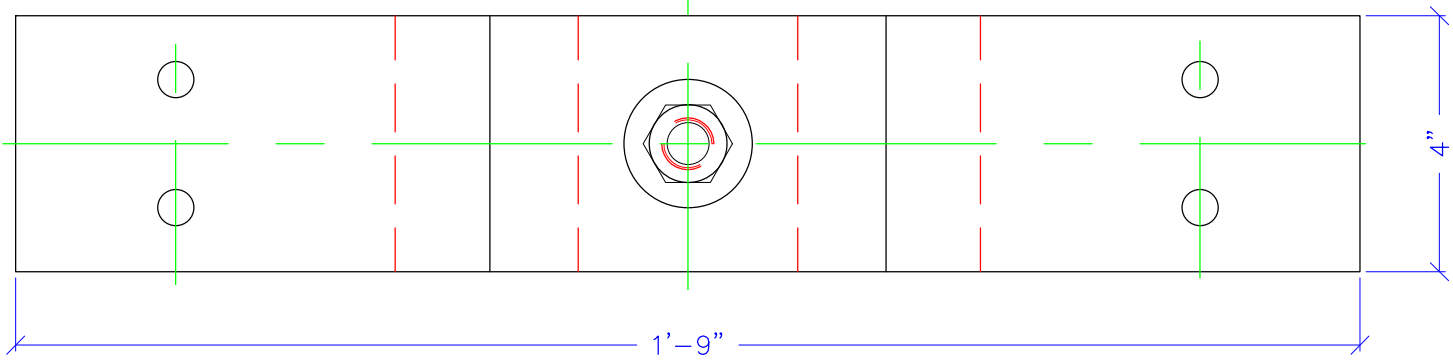
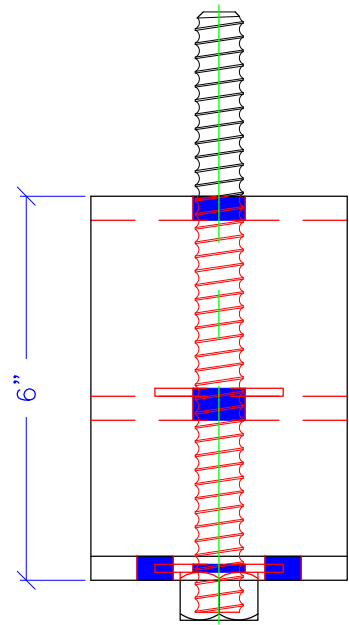
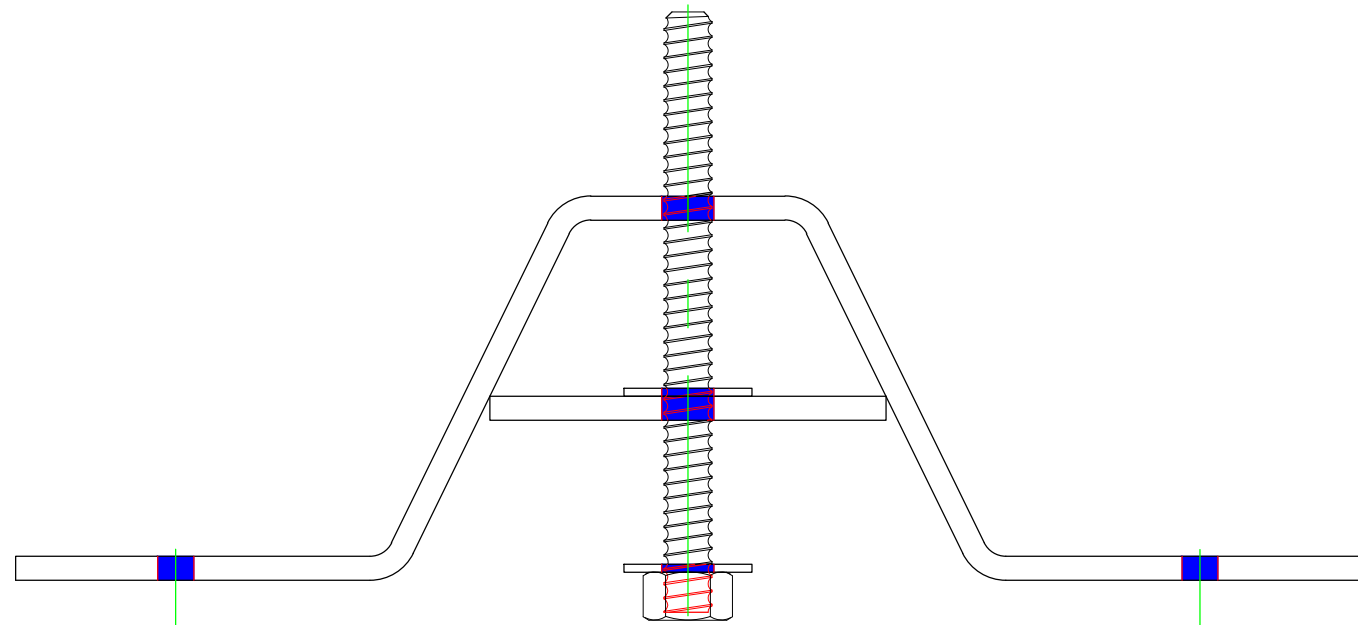

UNLESS OTHERWISE SPECIFIED DIM. ARE IN INCHES. TOLERANCES ARE: FRACTIONS: $\pm \frac{1}{16}$ " ANGLES: $\pm 1^\circ$	CONTRACT NO.		SPECTRUM CONCRETE PRODUCTS, LLC.	
	APPROVALS	DATE		
	DRAWN	00-00-00	TITLE:	DECK RETAINER ASSEMBLY
	CHECKED		SIZE	A
MATERIAL	ISSUED	DWG NO.	REV.	
		SCALE	SHEET	

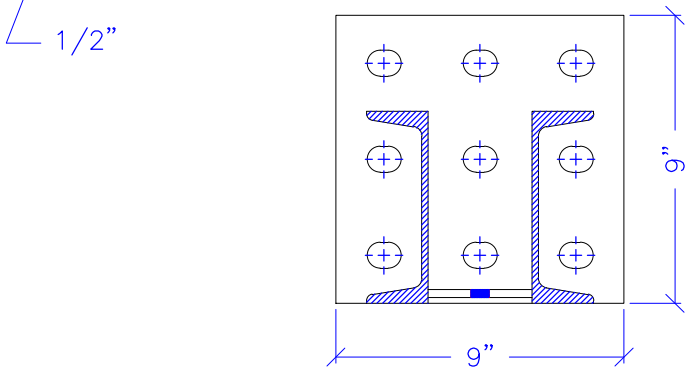
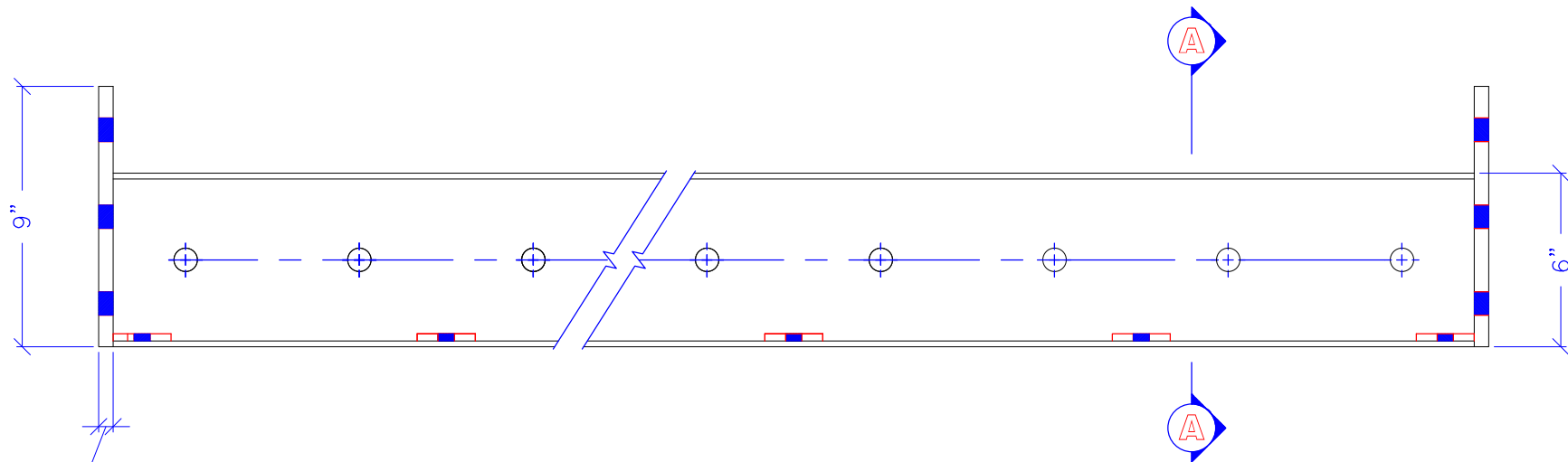
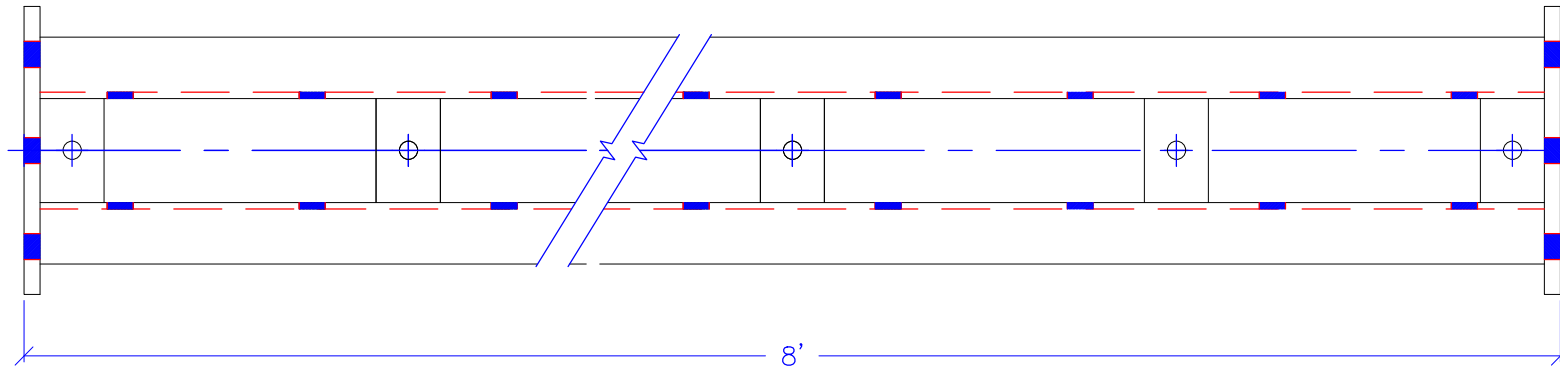

END VIEW

UNLESS OTHERWISE SPECIFIED DIM. ARE IN INCHES. TOLERANCES ARE: FRACTIONS: $\pm \frac{1}{8}$ " ANGLES: $\pm 1^\circ$	CONTRACT NO.		SPECTRUM CONCRETE PRODUCTS, LLC.	
	APPROVALS	DATE		
	DRAWN	00-00-00	TITLE:	C6 DOUBLE CHANNEL WALER
	CHECKED		SIZE	DWG NO.
MATERIAL	ISSUED		A	
			SCALE	SHEET

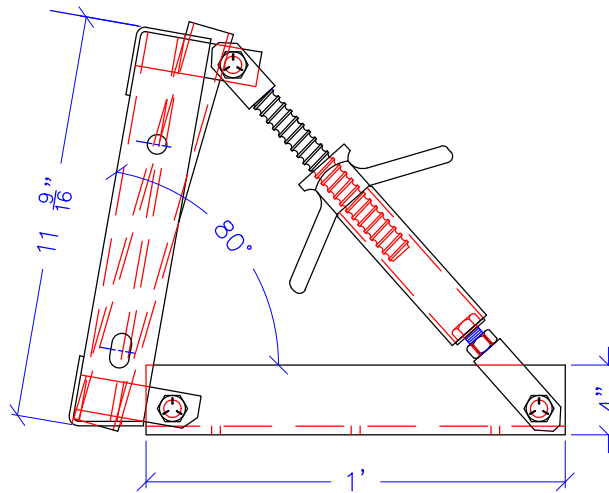
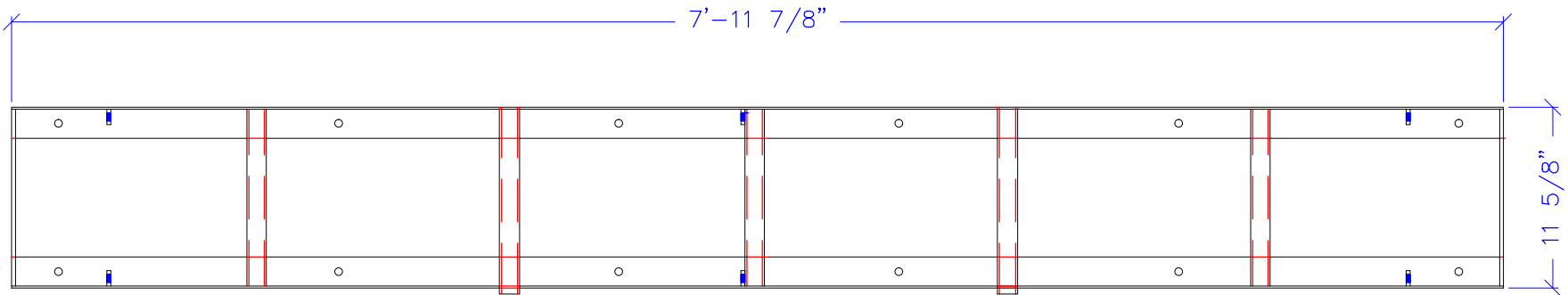

SIDE ELEVATION

UNLESS OTHERWISE SPECIFIED DIM. ARE IN INCHES. TOLERANCES ARE: FRACTIONS: $\pm \frac{1}{16}"$ ANGLES: $\pm 1^\circ$	CONTRACT NO.		SPECTRUM CONCRETE PRODUCTS, LLC.	
	APPROVALS	DATE		
	DRAWN	00-00-00	TITLE:	EDGE OF DECK FORM
	CHECKED		SIZE	DWG NO.
MATERIAL	ISSUED		A	
			SCALE	SHEET

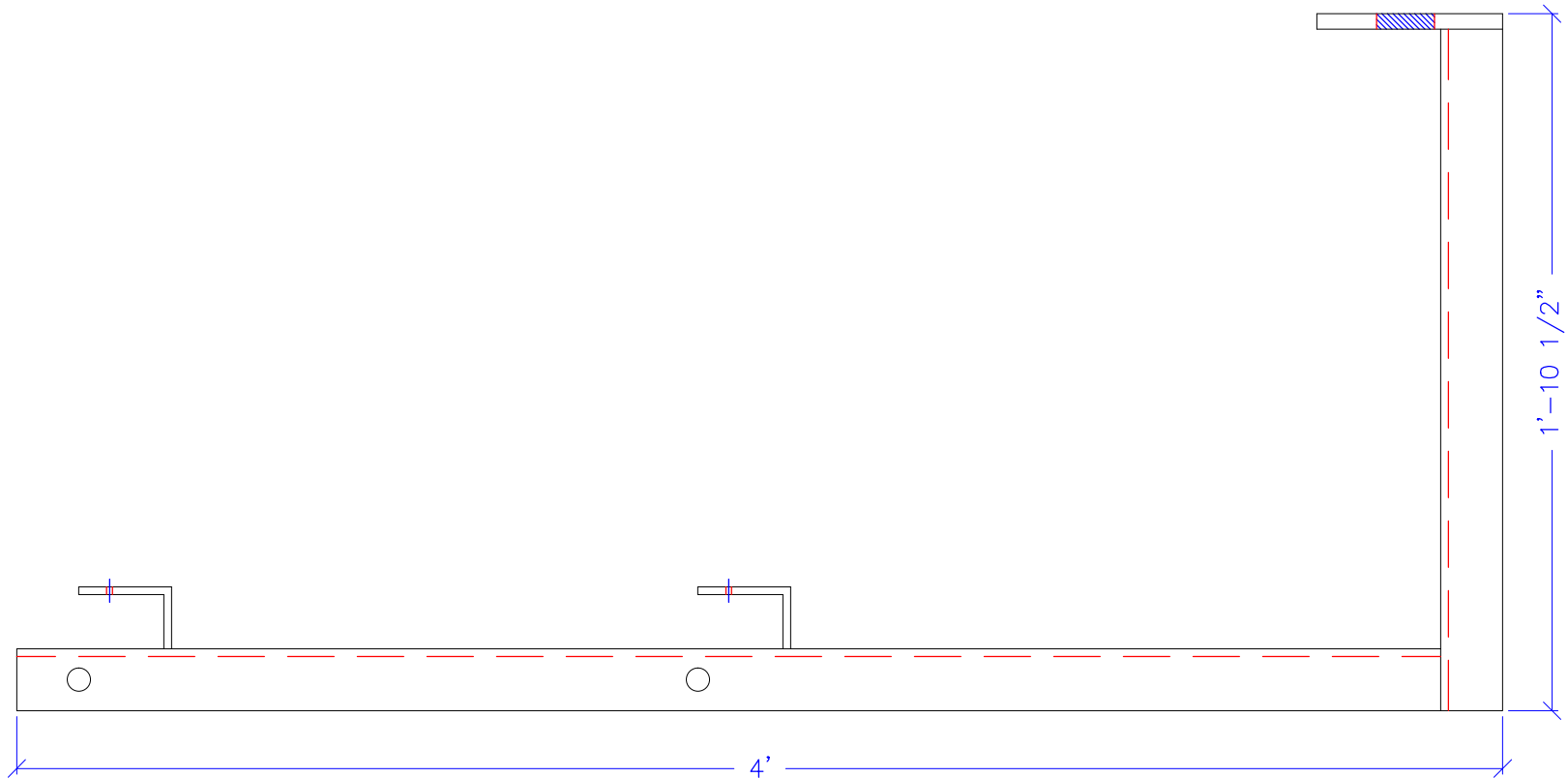
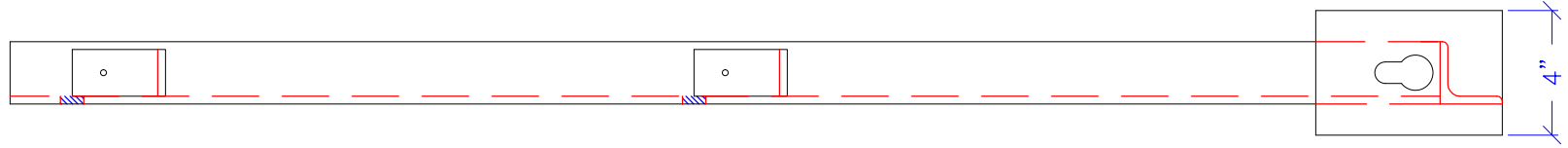

UNLESS OTHERWISE SPECIFIED DIM. ARE IN INCHES. TOLERANCES ARE: FRACTIONS: $\pm \frac{1}{16}$ " ANGLES: $\pm 1^\circ$	CONTRACT NO.		SPECTRUM CONCRETE PRODUCTS, LLC.	
	APPROVALS	DATE		
	DRAWN	00-00-00	TITLE:	EDGE OF DECK SAFETY RAIL BRACKET
	CHECKED		SIZE	DWG NO.
MATERIAL	ISSUED		A	
			SCALE	SHEET

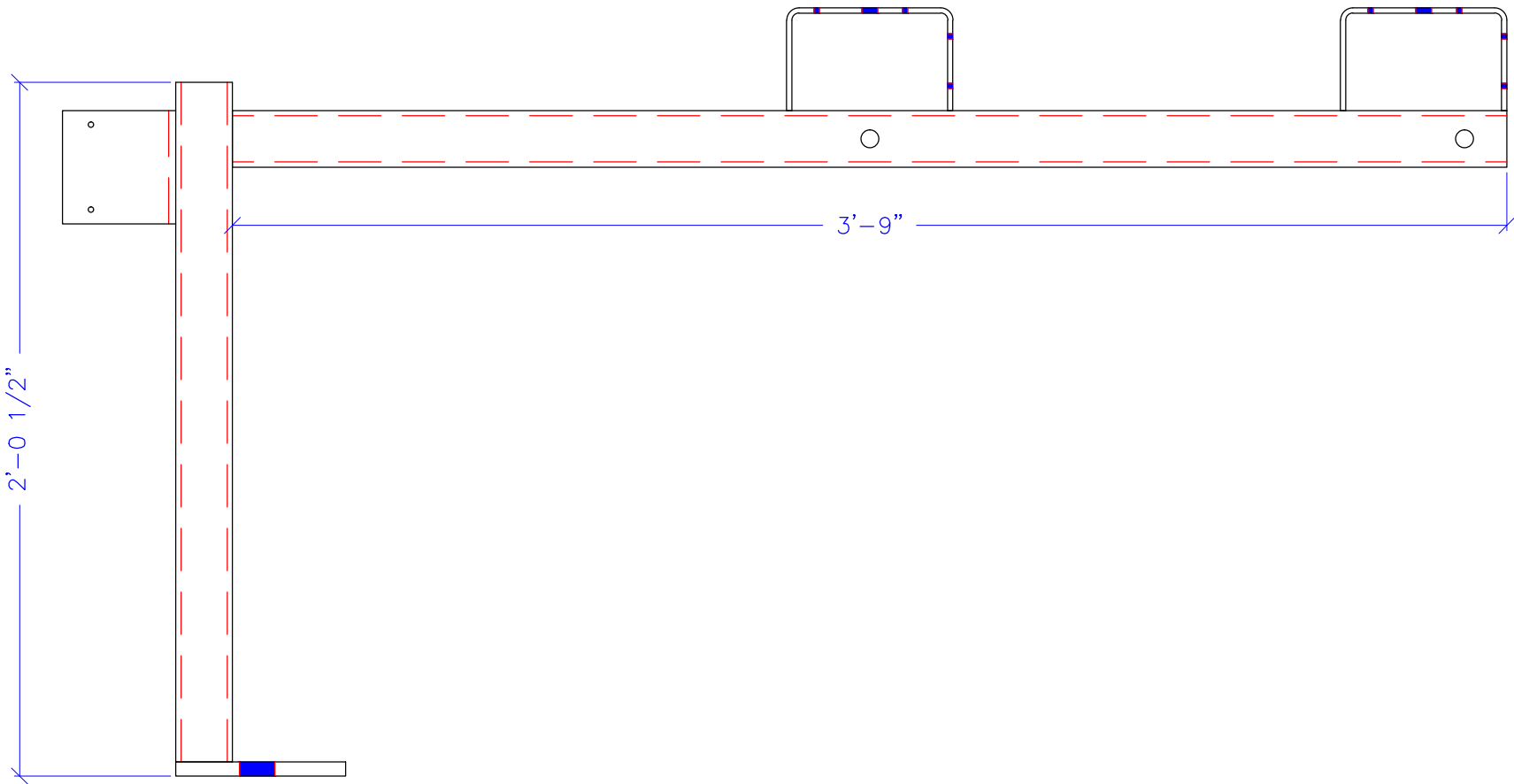
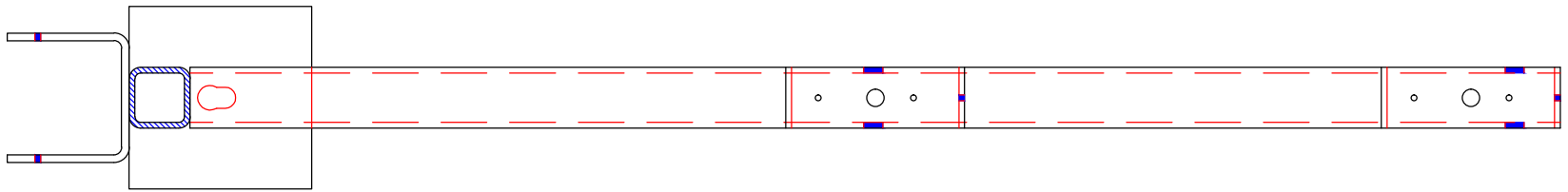

UNLESS OTHERWISE SPECIFIED DIM. ARE IN INCHES. TOLERANCES ARE: FRACTIONS: $\pm \frac{1}{16}$ " ANGLES: $\pm 1^\circ$	CONTRACT NO.		SPECTRUM CONCRETE PRODUCTS, LLC.	
	APPROVALS	DATE		
	DRAWN	00-00-00	TITLE: EOD BRACKET-SLIPOVER	
	CHECKED		SIZE A	DWG NO.
MATERIAL	ISSUED		SCALE	SHEET

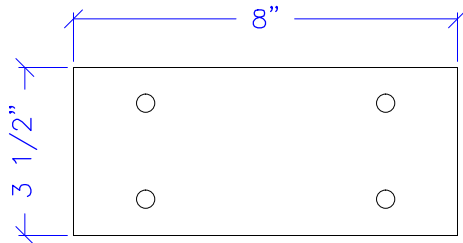

TOP VIEW

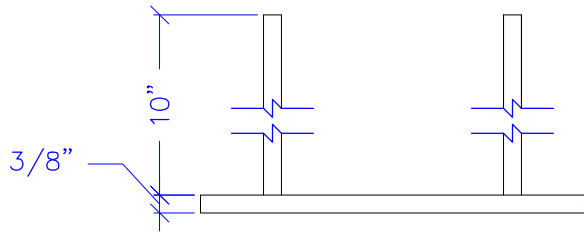

FRONT VIEW

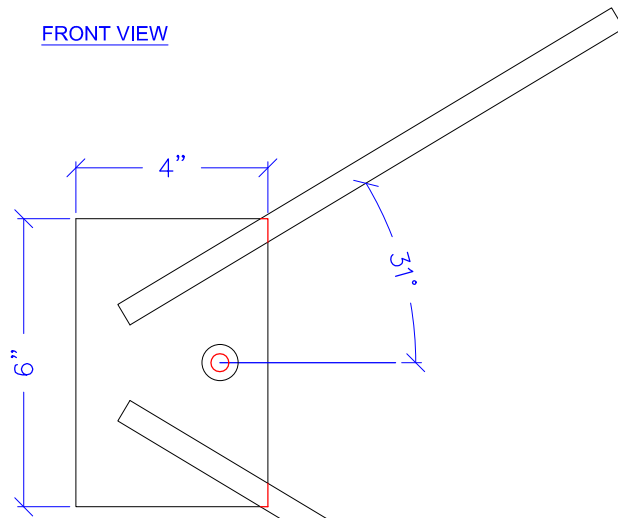

TOP VIEW

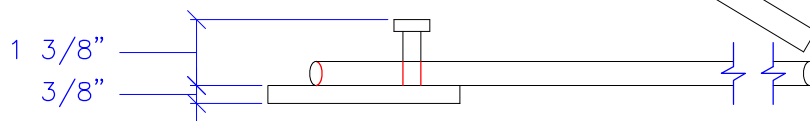

SIDE VIEW

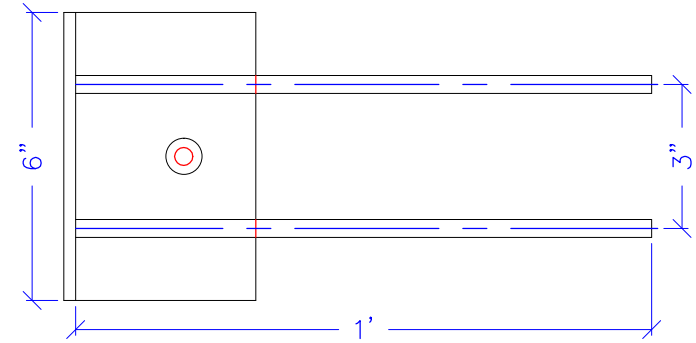

TOP VIEW

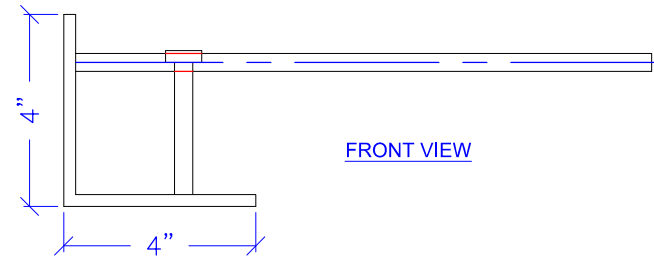

FRONT VIEW

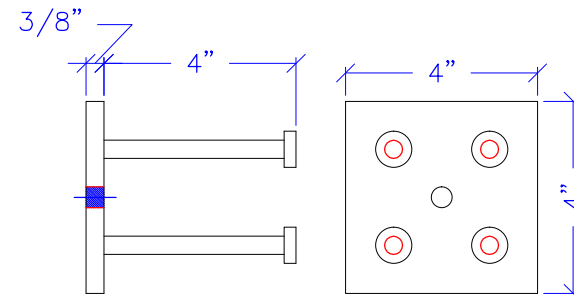

FRONT VIEW

TOP VIEW

UNLESS OTHERWISE SPECIFIED DIM. ARE IN INCHES. TOLERANCES ARE: FRACTIONS: $\pm \frac{1}{16}$ " ANGLES: $\pm 1^\circ$	CONTRACT NO.		SPECTRUM CONCRETE PRODUCTS, LLC.	
	APPROVALS	DATE		
	DRAWN	00-00-00	TITLE: EMBED PLATES	
	CHECKED		SIZE	DWG NO.
MATERIAL	ISSUED		A	
			SCALE	SHEET

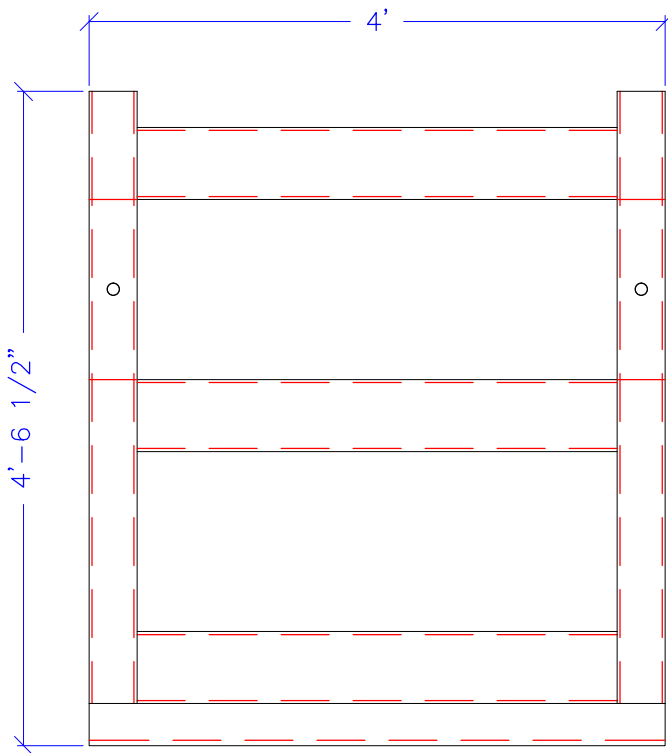

SIDE VIEW

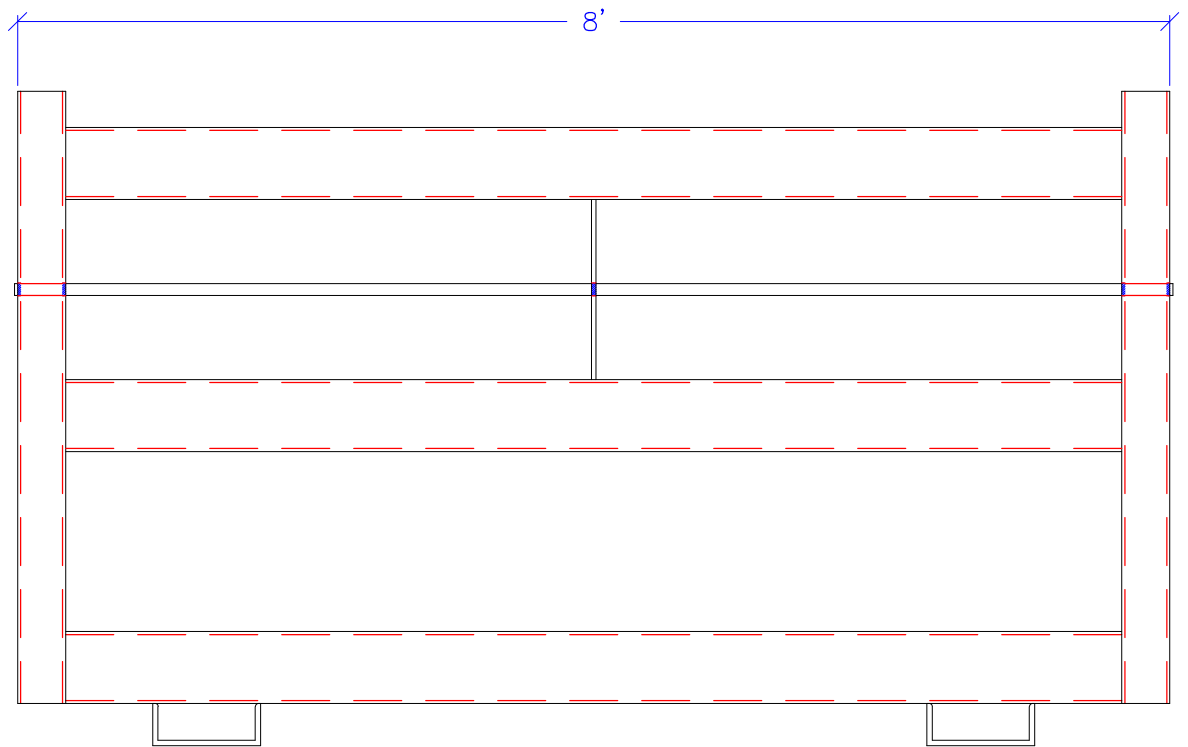

FRONT VIEW

UNLESS OTHERWISE SPECIFIED DIM. ARE IN INCHES. TOLERANCES ARE: FRACTIONS: $\pm \frac{1}{16}$ " ANGLES: $\pm 1^\circ$	CONTRACT NO.		SPECTRUM CONCRETE PRODUCTS, LLC.	
	APPROVALS	DATE		
	DRAWN	00-00-00	TITLE:	FALSWORK STRIPPING BASKET
	CHECKED		SIZE	A
MATERIAL	ISSUED		DWG NO.	REV.
			SCALE	SHEET

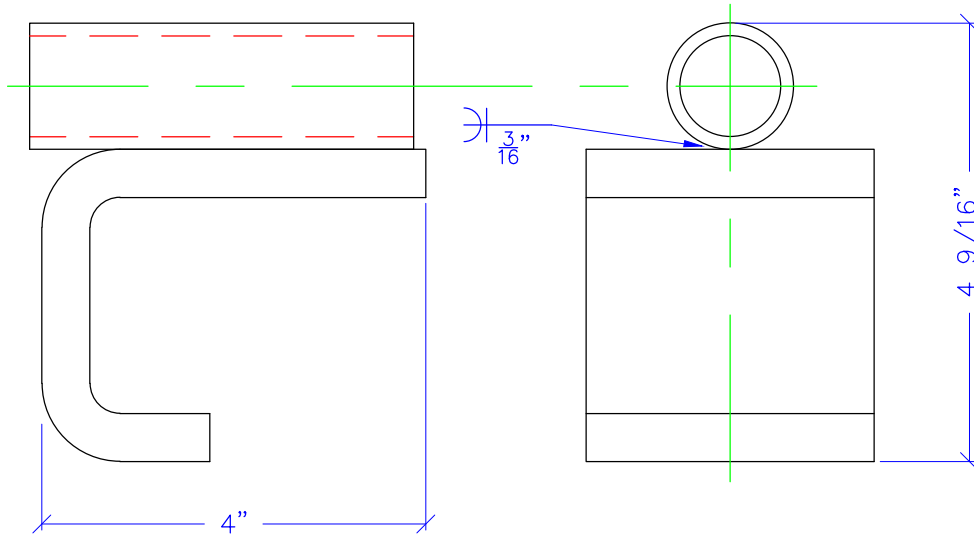

UNLESS OTHERWISE SPECIFIED DIM. ARE IN INCHES. TOLERANCES ARE: FRACTIONS: $\pm \frac{1}{16}$ " ANGLES: $\pm 1^\circ$	CONTRACT NO.		SPECTRUM CONCRETE PRODUCTS, LLC.	
	APPROVALS	DATE		
	DRAWN	00-00-00	TITLE: FLANGE CLIP	
	CHECKED		SIZE A	DWG NO.
MATERIAL	ISSUED		SCALE	SHEET

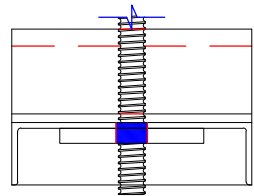
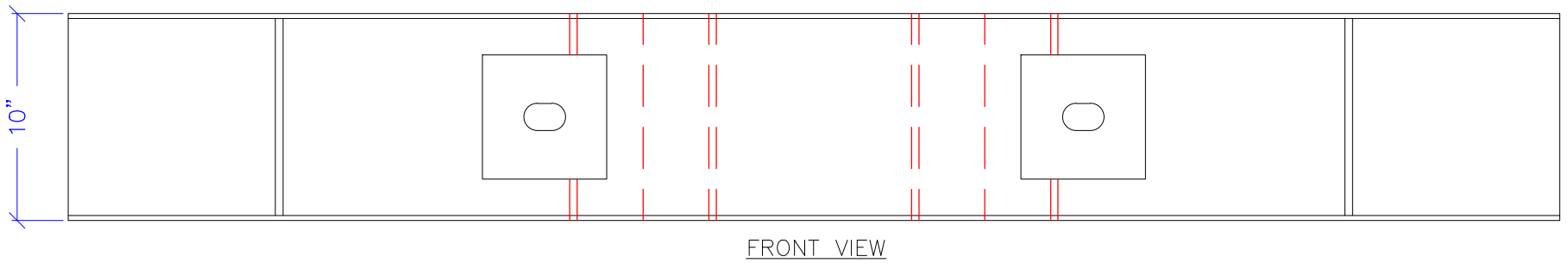
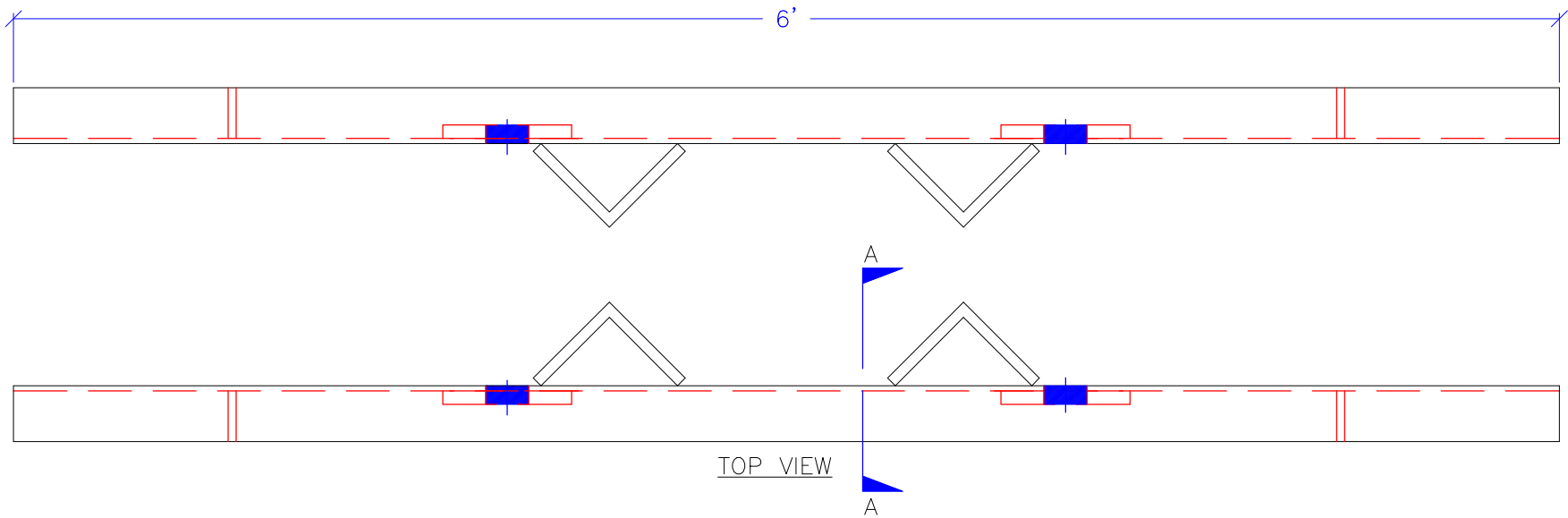

SECTION VIEW A-A

UNLESS OTHERWISE SPECIFIED DIM. ARE IN INCHES. TOLERANCES ARE: FRACTIONS: $\pm \frac{1}{16}$ " ANGLES: $\pm 1^\circ$	CONTRACT NO.		SPECTRUM CONCRETE PRODUCTS, LLC. FRICION COLLAR
	APPROVALS	DATE	
	DRAWN	00-00-00	
	CHECKED		
MATERIAL	ISSUED		TITLE: SIZE: A DWG NO. REV. SCALE SHEET

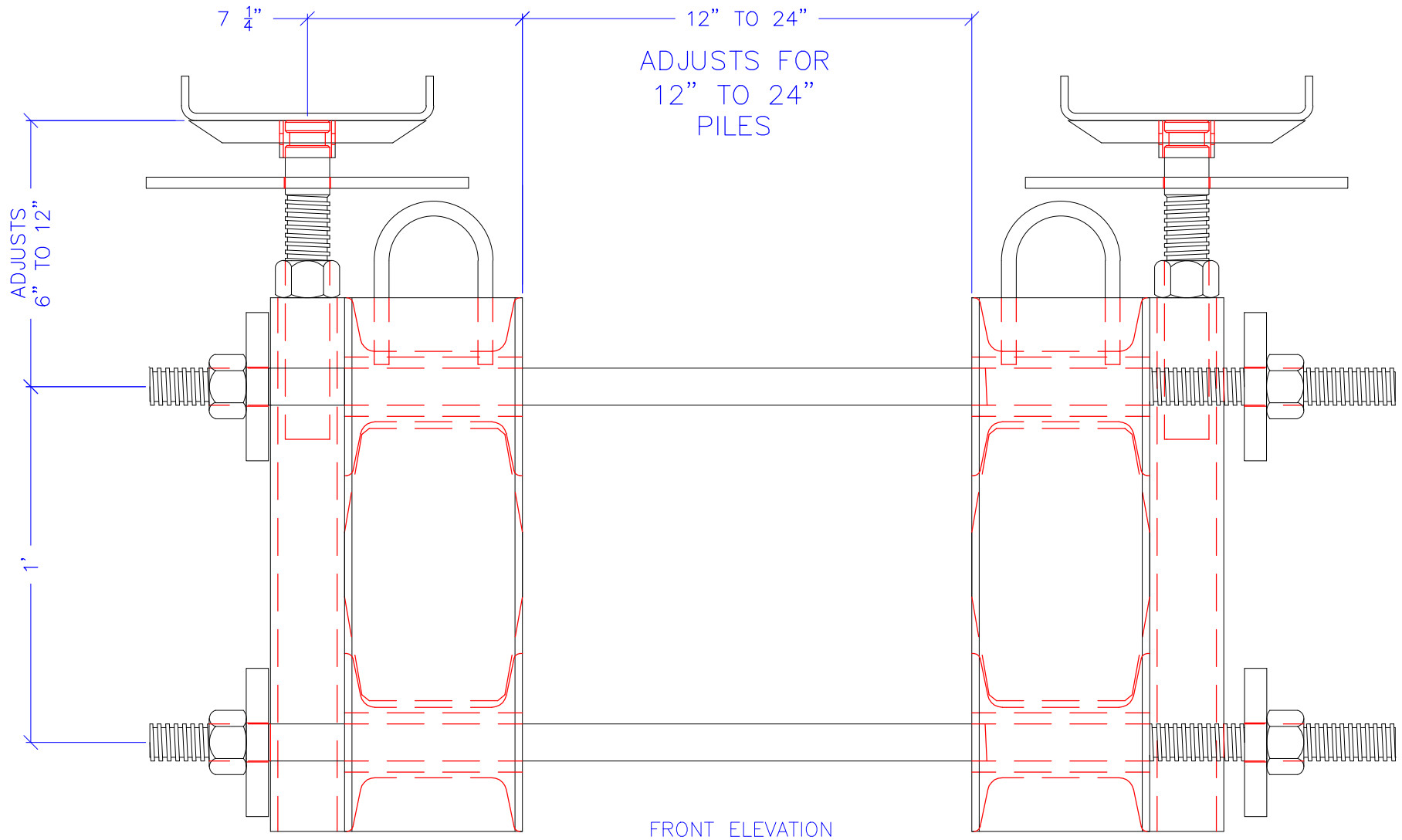

UNLESS OTHERWISE SPECIFIED DIM. ARE IN INCHES. TOLERANCES ARE: FRACTIONS: $\pm \frac{1}{16}$ " ANGLES: $\pm 1^\circ$	CONTRACT NO.		SPECTRUM CONCRETE PRODUCTS, LLC. TITLE: FRICION COLLAR 25K
	APPROVALS	DATE	
	DRAWN	00-00-00	
	CHECKED		
MATERIAL	ISSUED	SCALE	SIZE DWG NO. REV. A SHEET

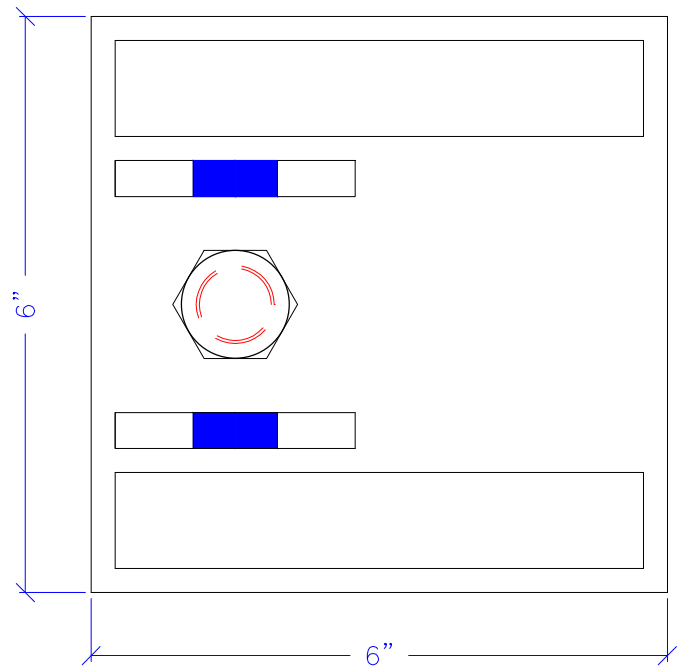
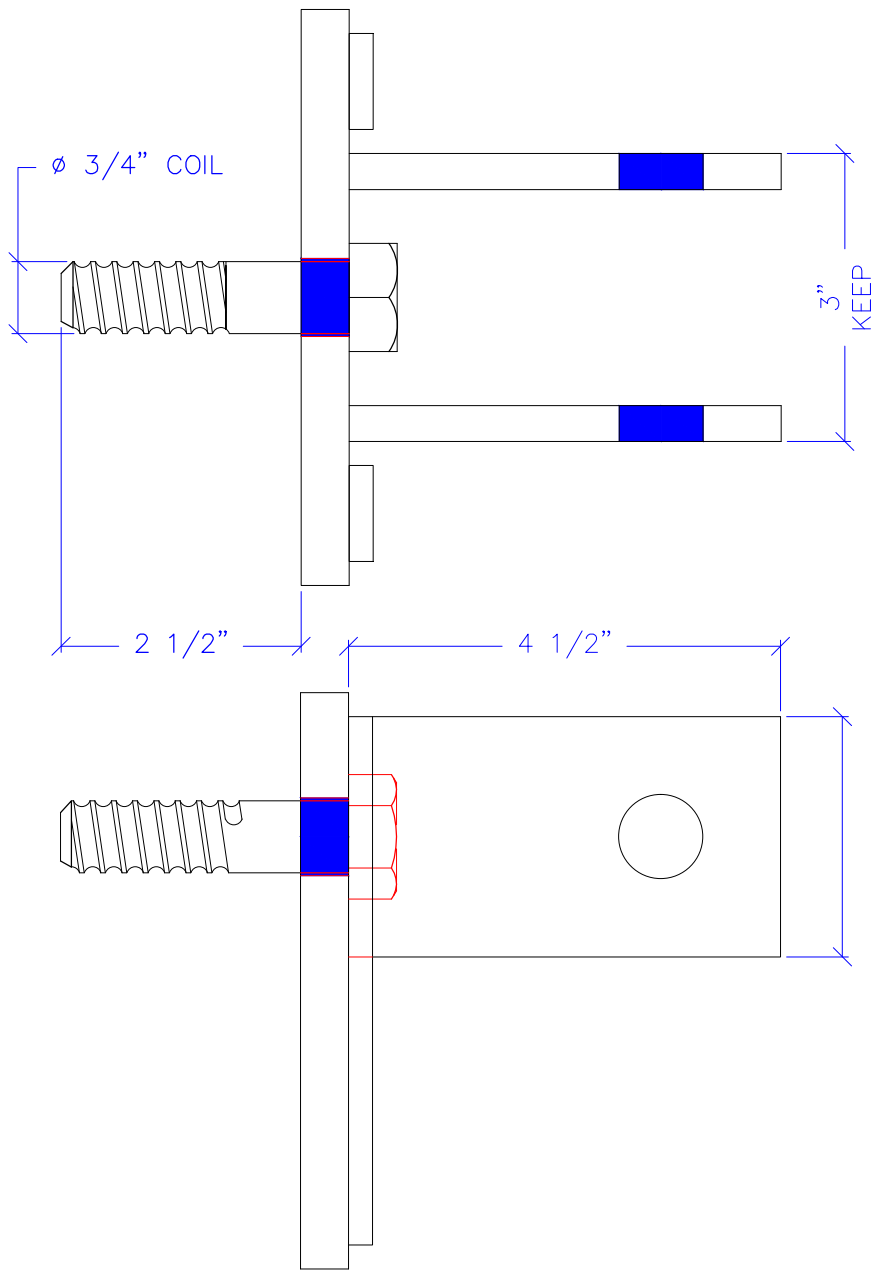

UNLESS OTHERWISE SPECIFIED DIM. ARE IN INCHES. TOLERANCES ARE: FRACTIONS: $\pm \frac{1}{16}$ " ANGLES: $\pm 1^\circ$	CONTRACT NO.		SPECTRUM CONCRETE PRODUCTS, LLC.	
	APPROVALS	DATE		
	DRAWN	00-00-00	TITLE:	GANG FORM BRACE BRACKET
	CHECKED		SIZE	A
MATERIAL	ISSUED	DWG NO.		REV.
		SCALE		SHEET

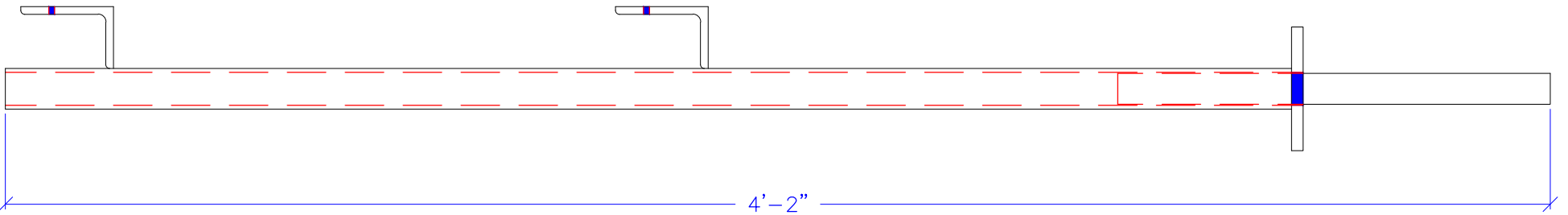
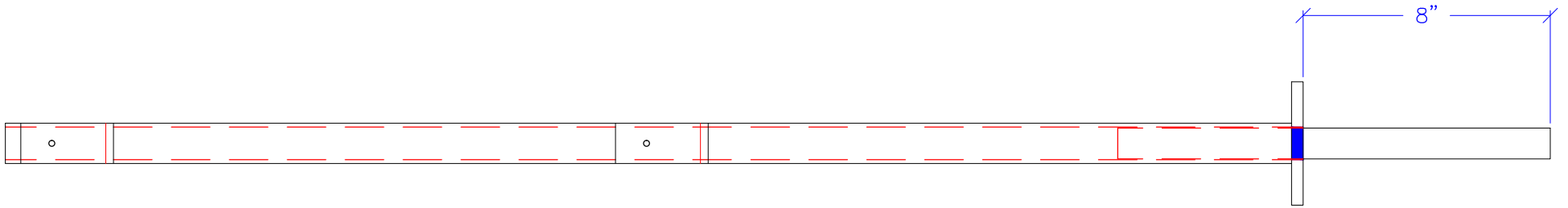

UNLESS OTHERWISE SPECIFIED DIM. ARE IN INCHES. TOLERANCES ARE: FRACTIONS: $\pm \frac{1}{16}$ " ANGLES: $\pm 1^\circ$	CONTRACT NO.		SPECTRUM CONCRETE PRODUCTS, LLC.	
	APPROVALS	DATE		
	DRAWN	00-00-00	TITLE:	HANDRAIL POST
	CHECKED		SIZE	A
MATERIAL	ISSUED	DWG NO.		REV.
		SCALE		SHEET

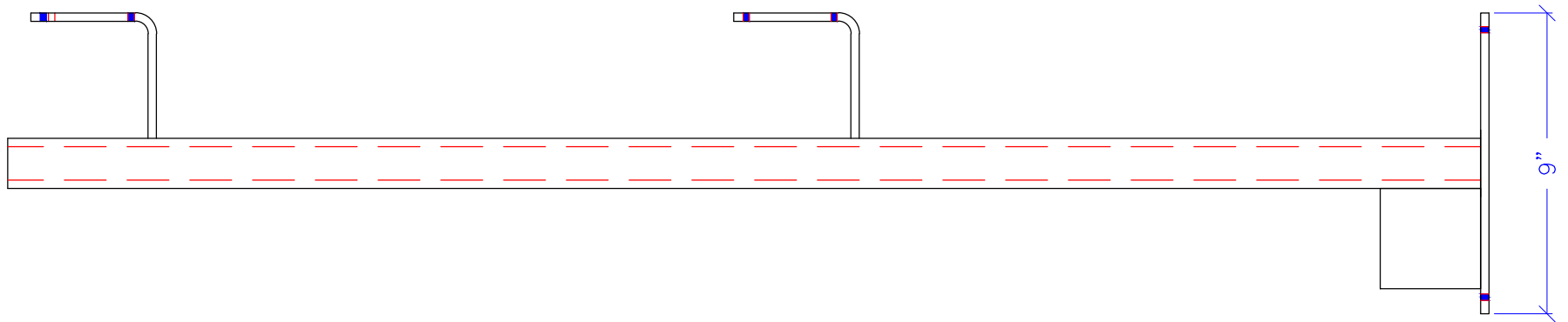
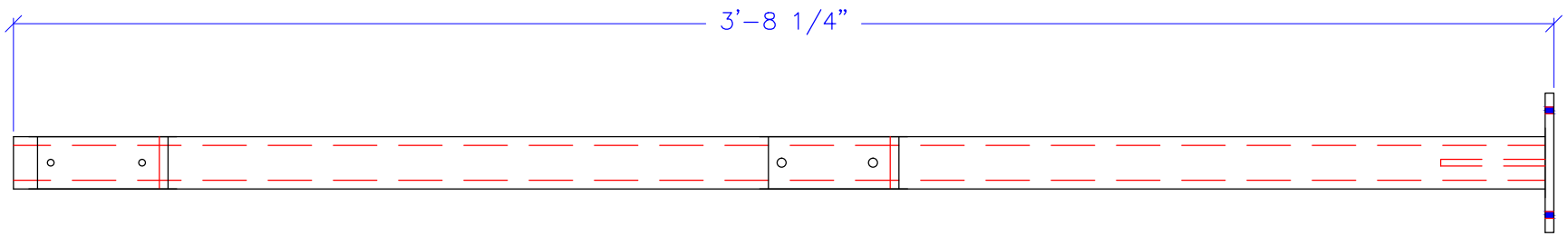

UNLESS OTHERWISE SPECIFIED DIM. ARE IN INCHES. TOLERANCES ARE: FRACTIONS: $\pm \frac{1}{8}$ " ANGLES: $\pm 1^\circ$	CONTRACT NO.		SPECTRUM CONCRETE PRODUCTS, LLC.	
	APPROVALS	DATE		
	DRAWN	00-00-00	TITLE:	HANDRAIL POST WITH FLAT PLATE
	CHECKED		SIZE	A
MATERIAL	ISSUED		DWG NO.	REV.
			SCALE	SHEET

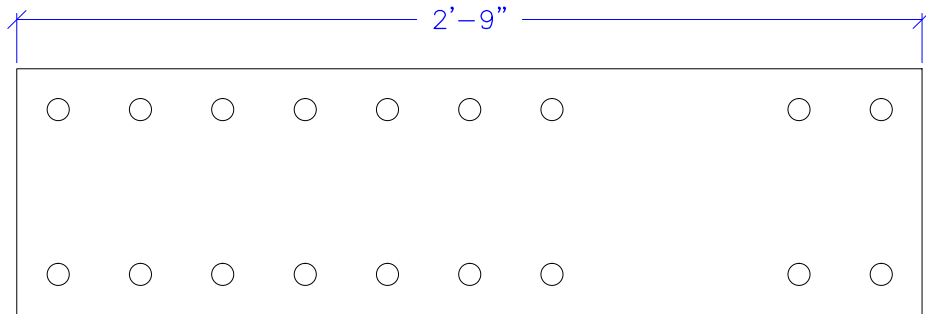
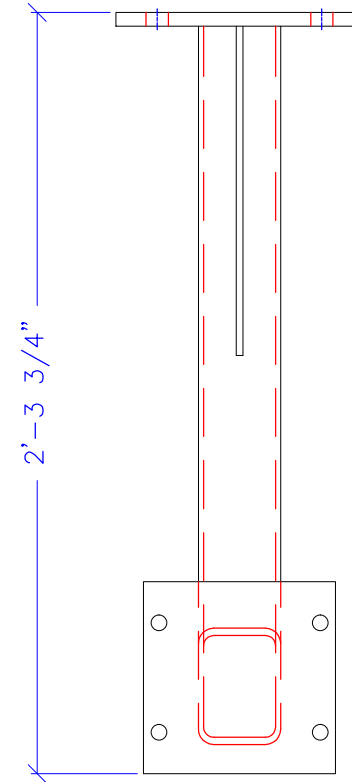
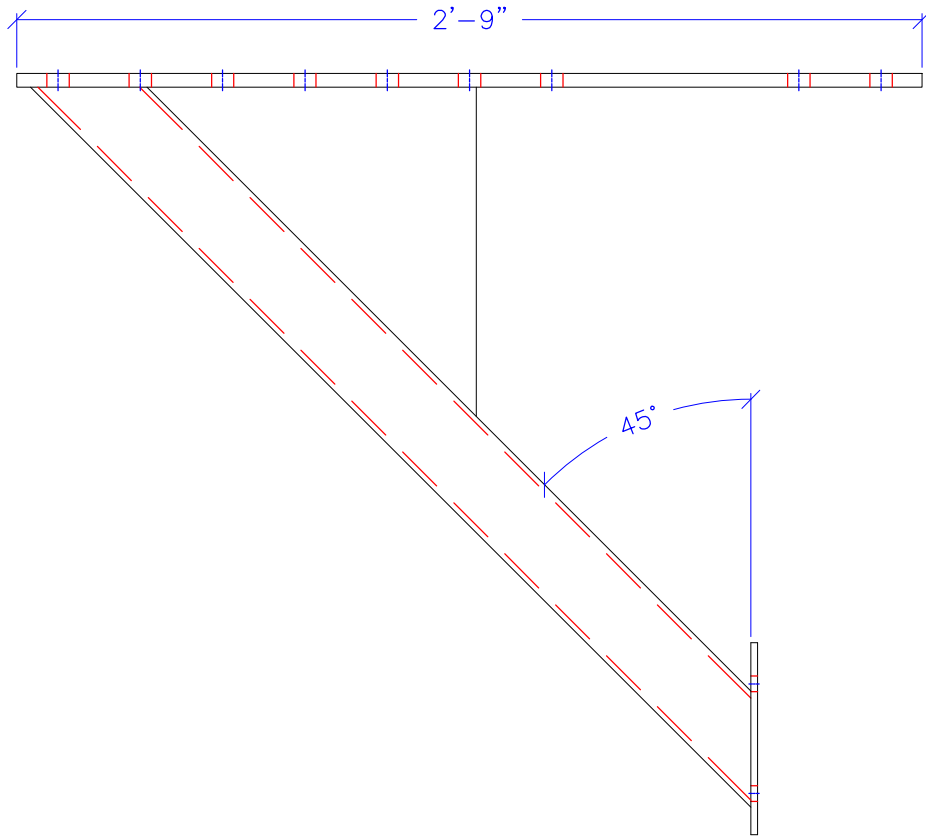

BASE PLATE DETAIL

UNLESS OTHERWISE SPECIFIED DIM. ARE IN INCHES. TOLERANCES ARE: FRACTIONS: $\pm \frac{1}{16}$ " ANGLES: $\pm 1^\circ$	CONTRACT NO.		SPECTRUM CONCRETE PRODUCTS, LLC.	
	APPROVALS	DATE		
	DRAWN	00-00-00	TITLE: HAUNCH BRACKET	
	CHECKED		SIZE A	DWG NO.
MATERIAL	ISSUED		SCALE	SHEET

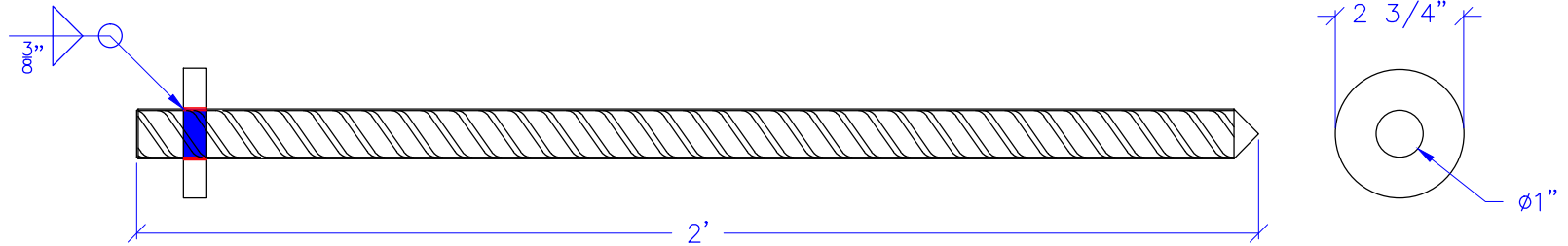
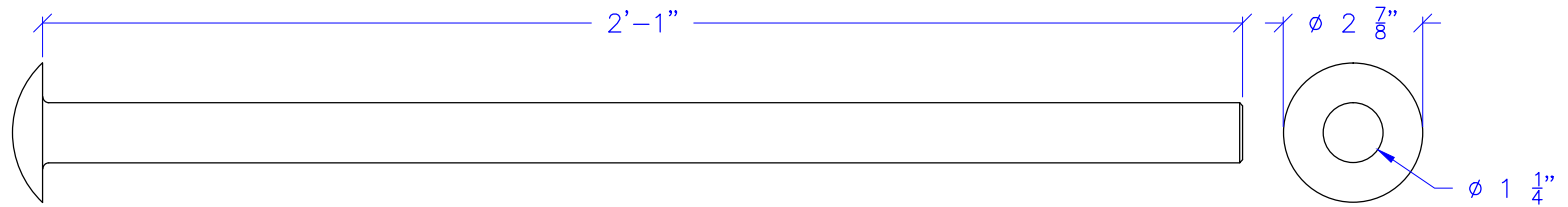

UNLESS OTHERWISE SPECIFIED DIM. ARE IN INCHES. TOLERANCES ARE: FRACTIONS: $\pm \frac{1}{16}"$ ANGLES: $\pm 1^\circ$	CONTRACT NO.		SPECTRUM CONCRETE PRODUCTS, LLC.	
	APPROVALS	DATE		
	DRAWN	00-00-00	TITLE: K-RAIL PIN & STAKE	
	CHECKED		SIZE A	DWG NO.
MATERIAL	ISSUED		SCALE	SHEET

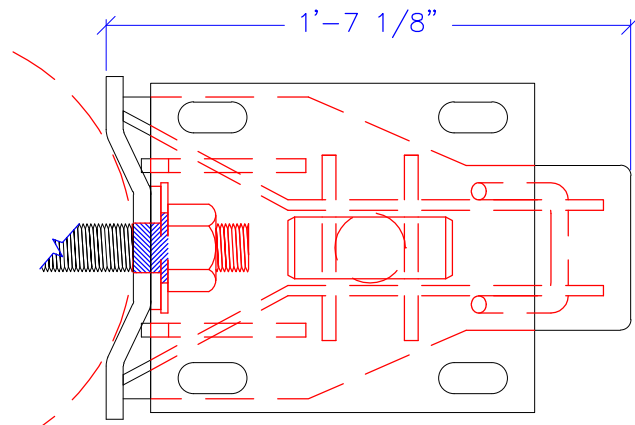

TOP VIEW

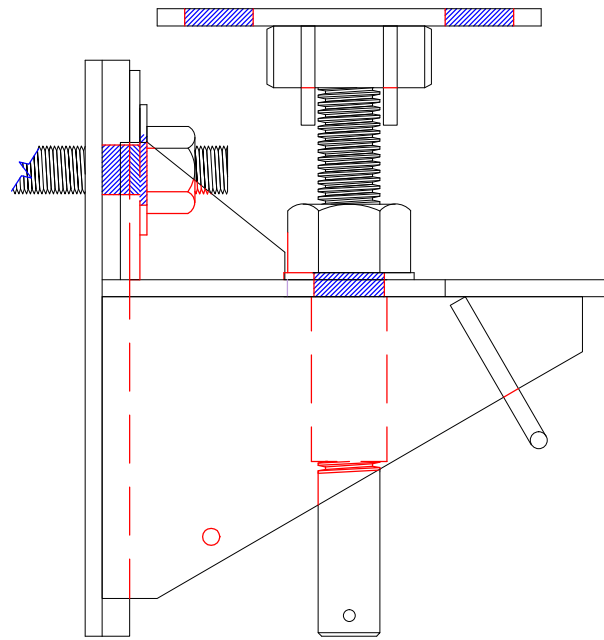

SIDE VIEW

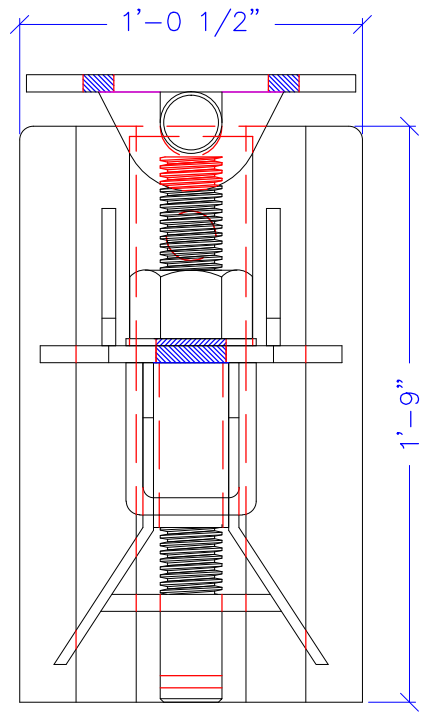

FRONT VIEW

UNLESS OTHERWISE SPECIFIED DIM. ARE IN INCHES. TOLERANCES ARE: FRACTIONS: $\pm \frac{1}{16}$ " ANGLES: $\pm 1^\circ$	CONTRACT NO.		SPECTRUM CONCRETE PRODUCTS, LLC.	
	APPROVALS	DATE		
	DRAWN	00-00-00	TITLE: 50 KIP JACK	
	CHECKED		SIZE A	DWG NO.
MATERIAL	ISSUED		SCALE	SHEET

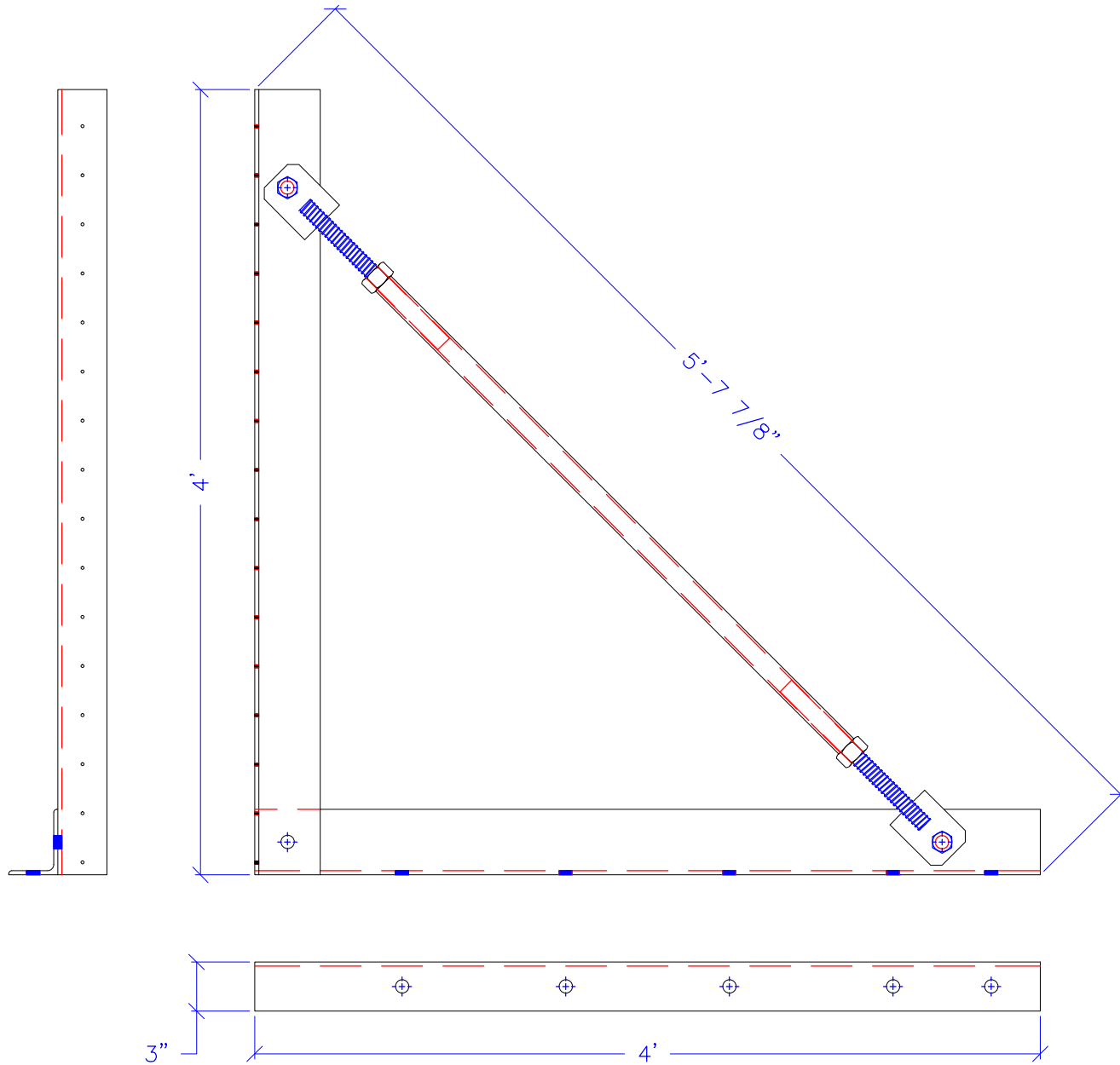

OTHER SIZES AVAILABLE UPON REQUEST

UNLESS OTHERWISE SPECIFIED DIM. ARE IN INCHES. TOLERANCES ARE: FRACTIONS: $\pm \frac{1}{16}$ " ANGLES: $\pm 1^\circ$	CONTRACT NO.		SPECTRUM CONCRETE PRODUCTS, LLC. TITLE: 48" LACKEY BRACKET SIZE: A DWG NO. _____ SCALE _____ SHEET _____
	APPROVALS	DATE	
	DRAWN	00-00-00	
	CHECKED		
MATERIAL	ISSUED		REV.

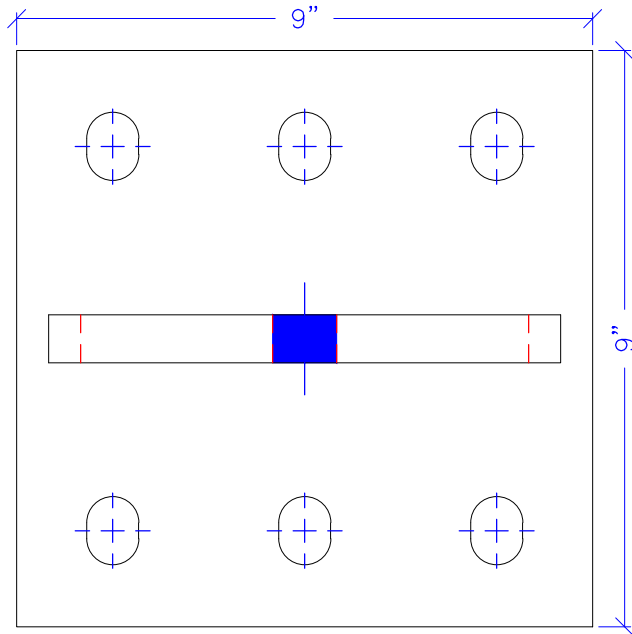

TOP VIEW

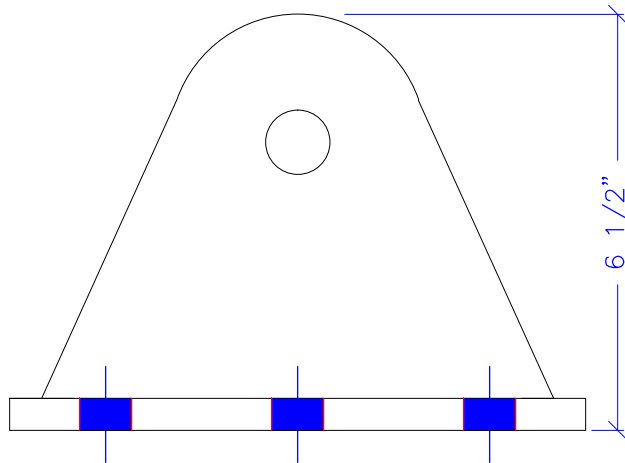

FRONT VIEW

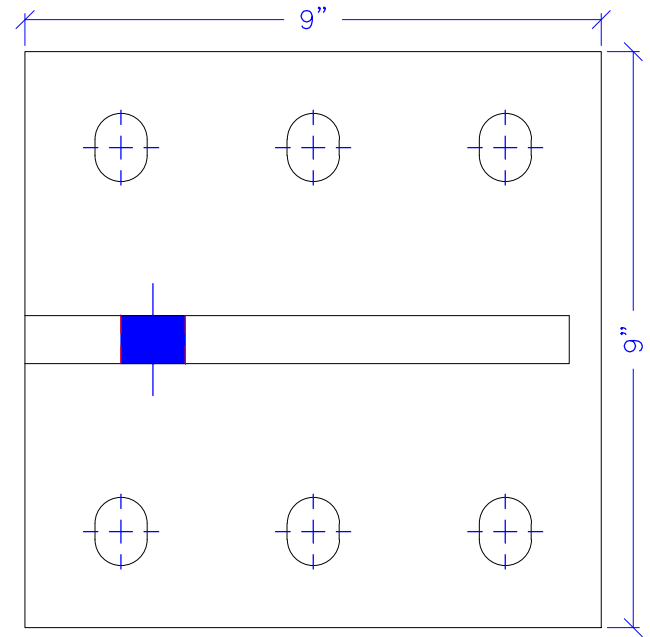

TOP VIEW

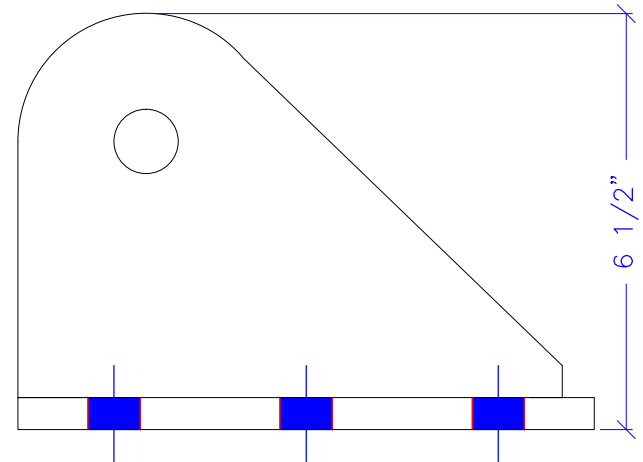

FRONT VIEW

UNLESS OTHERWISE SPECIFIED DIM. ARE IN INCHES. TOLERANCES ARE: FRACTIONS: $\pm \frac{1}{16}$ " ANGLES: $\pm 1^\circ$	CONTRACT NO.		SPECTRUM CONCRETE PRODUCTS, LLC.	
	APPROVALS	DATE		
	DRAWN	00-00-00	TITLE:	LIFTING EYE / OFFSET LIFTING EYE
	CHECKED		SIZE	DWG NO.
MATERIAL	ISSUED		A	
			SCALE	SHEET

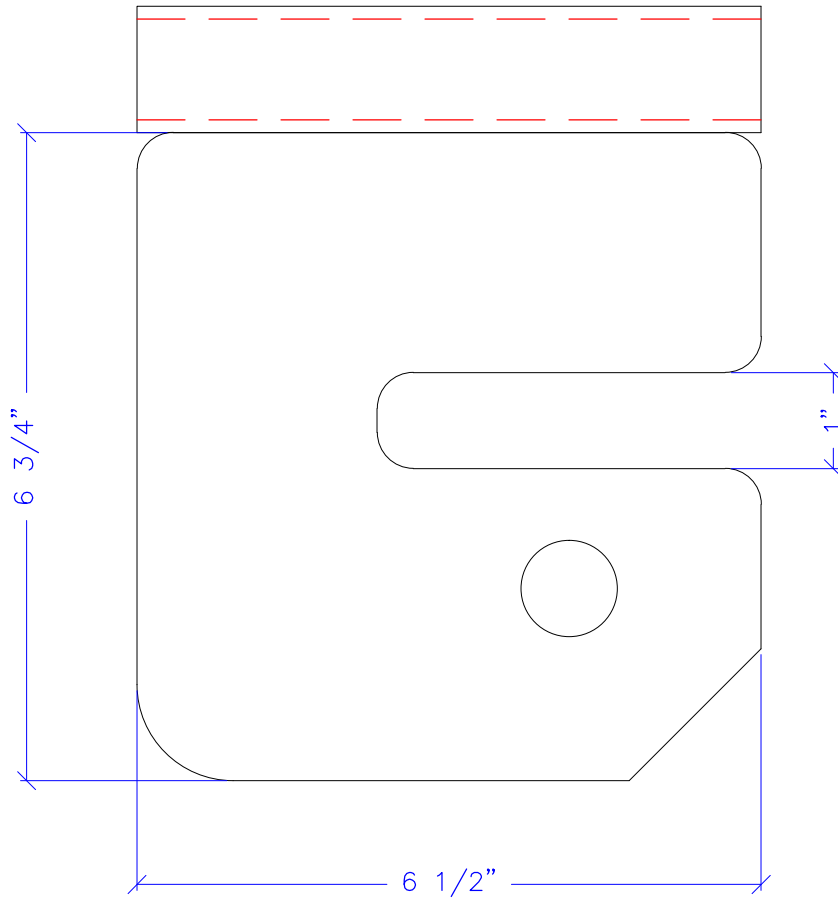

FRONT VIEW

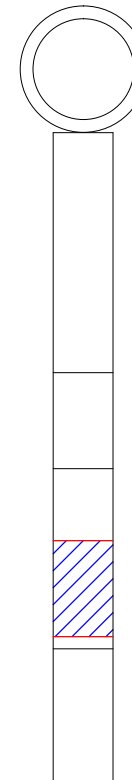

SIDE VIEW

UNLESS OTHERWISE SPECIFIED DIM. ARE IN INCHES. TOLERANCES ARE: FRACTIONS: $\pm \frac{1}{16}$ " ANGLES: $\pm 1^\circ$	CONTRACT NO.		SPECTRUM CONCRETE PRODUCTS, LLC.	
	APPROVALS	DATE		
	DRAWN	00-00-00	TITLE:	MODIFIED LONGITUDINAL PLATE
	CHECKED		SIZE	A
MATERIAL	ISSUED	DWG NO.		REV.
		SCALE		SHEET

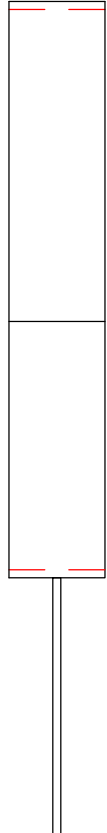
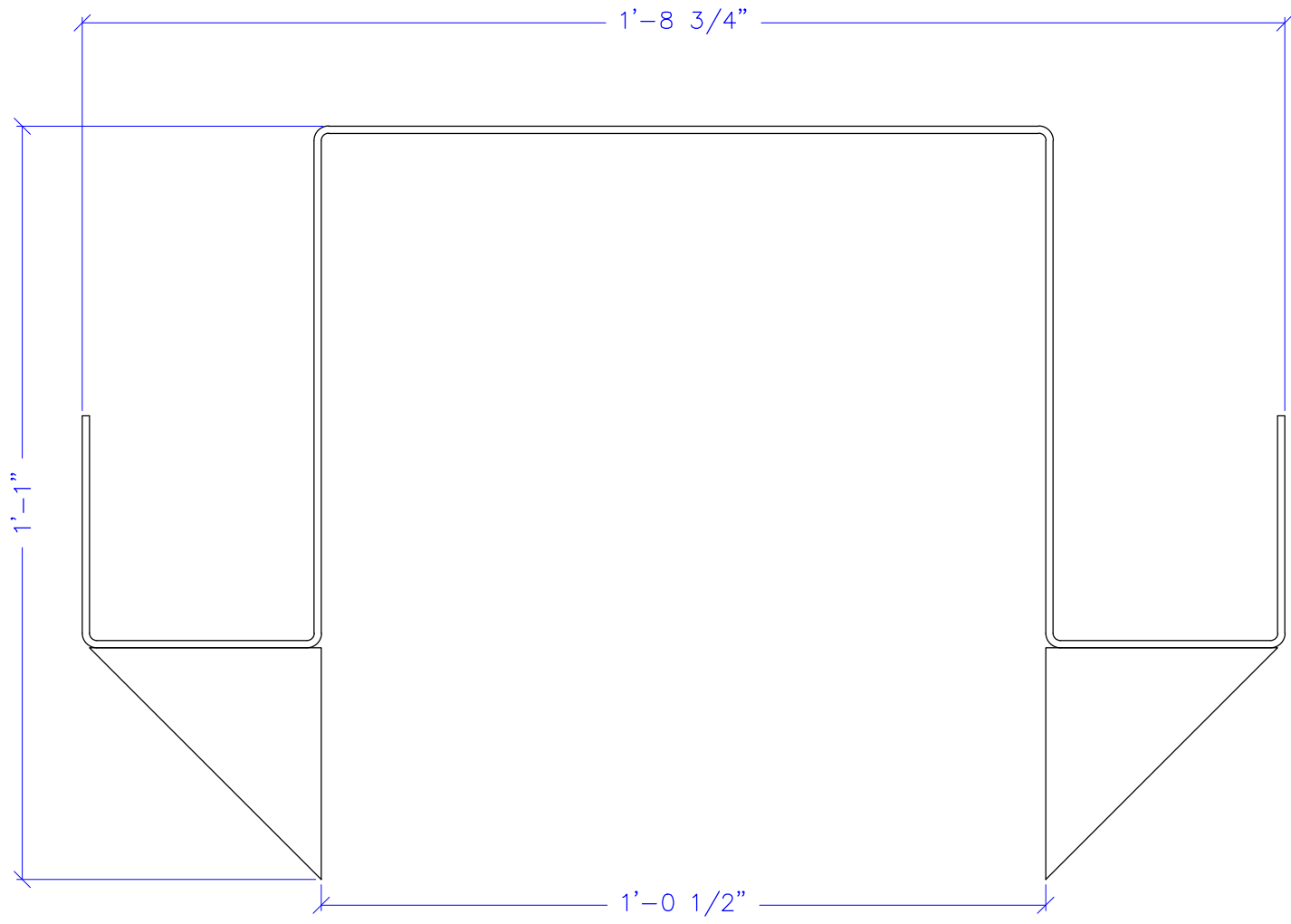

OTHER SIZES AVAILABLE UPON REQUEST

UNLESS OTHERWISE SPECIFIED DIM. ARE IN INCHES. TOLERANCES ARE: FRACTIONS: $\pm \frac{1}{16}$ " ANGLES: $\pm 1^\circ$	CONTRACT NO.		SPECTRUM CONCRETE PRODUCTS, LLC.	
	APPROVALS	DATE		
	DRAWN	00-00-00	TITLE:	12" LOST DECK HANGER
	CHECKED		SIZE	A
MATERIAL	ISSUED	DWG NO.		REV.
		SCALE		SHEET

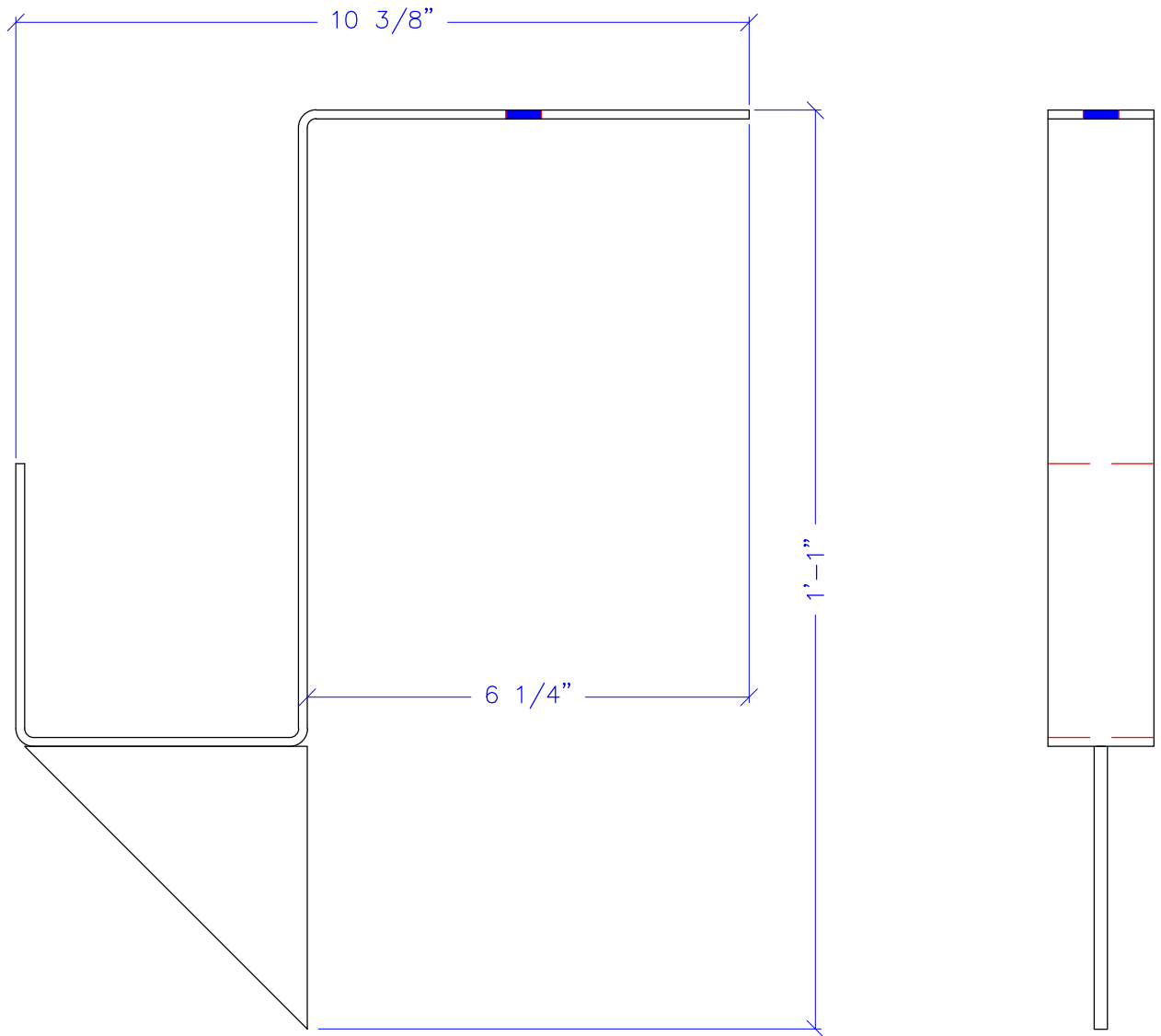

OTHER SIZES AVAILABLE UPON REQUEST

UNLESS OTHERWISE SPECIFIED DIM. ARE IN INCHES. TOLERANCES ARE: FRACTIONS: $\pm \frac{1}{16}$ " ANGLES: $\pm 1^\circ$	CONTRACT NO.		SPECTRUM CONCRETE PRODUCTS, LLC.	
	APPROVALS	DATE		
	DRAWN	00-00-00	TITLE: 12" LOST DECK HANGER HALF	
	CHECKED		SIZE A	DWG NO.
MATERIAL	ISSUED		SCALE	SHEET

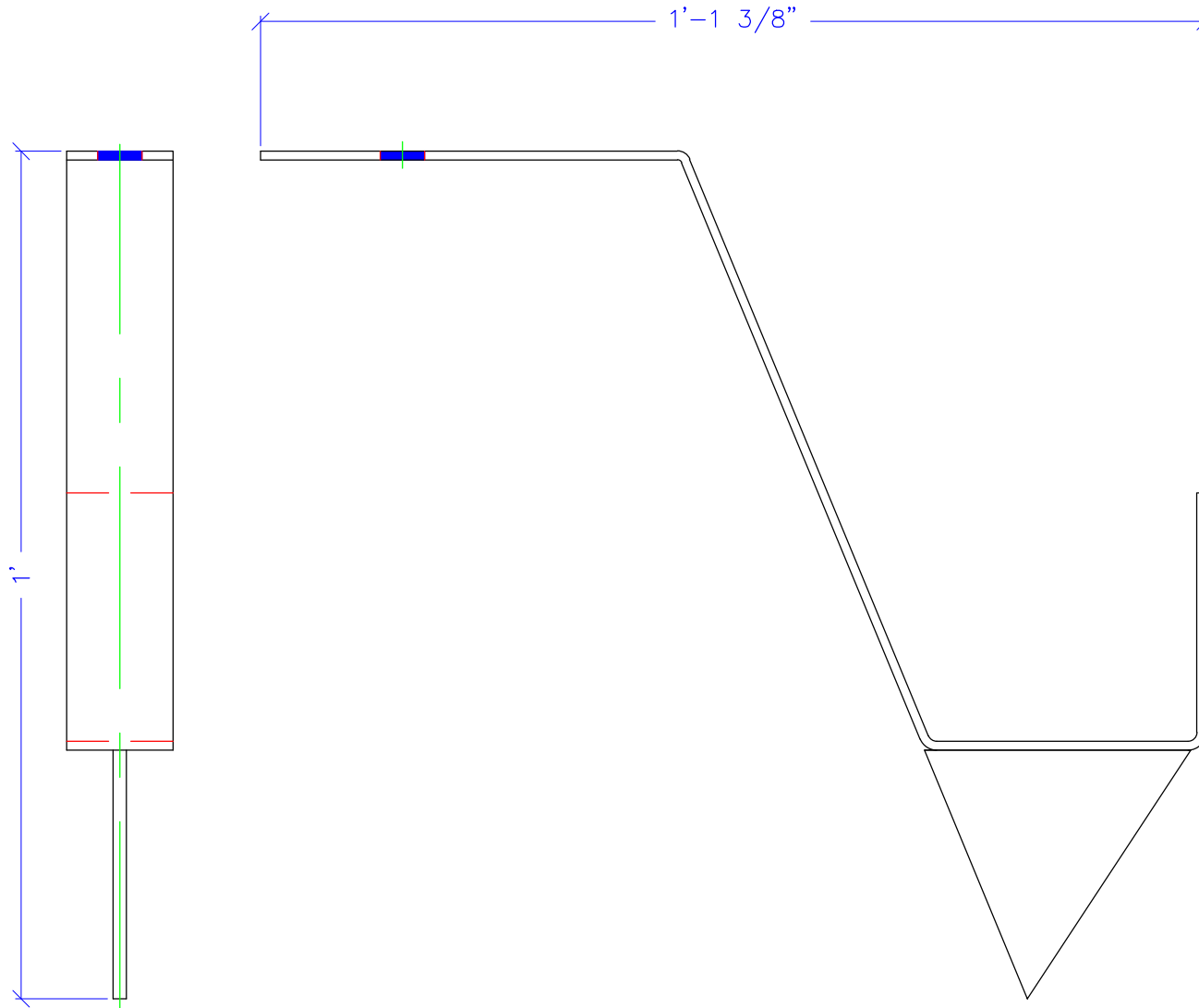

OTHER SIZES AVAILABLE UPON REQUEST

UNLESS OTHERWISE SPECIFIED DIM. ARE IN INCHES. TOLERANCES ARE: FRACTIONS: $\pm \frac{1}{16}$ " ANGLES: $\pm 1^\circ$	CONTRACT NO.		SPECTRUM CONCRETE PRODUCTS, LLC.	
	APPROVALS	DATE		
	DRAWN	00-00-00	TITLE:	12" LOST DECK HANGER SLOPPED
	CHECKED		SIZE	A
MATERIAL	ISSUED	DWG NO.		REV.
		SCALE		SHEET

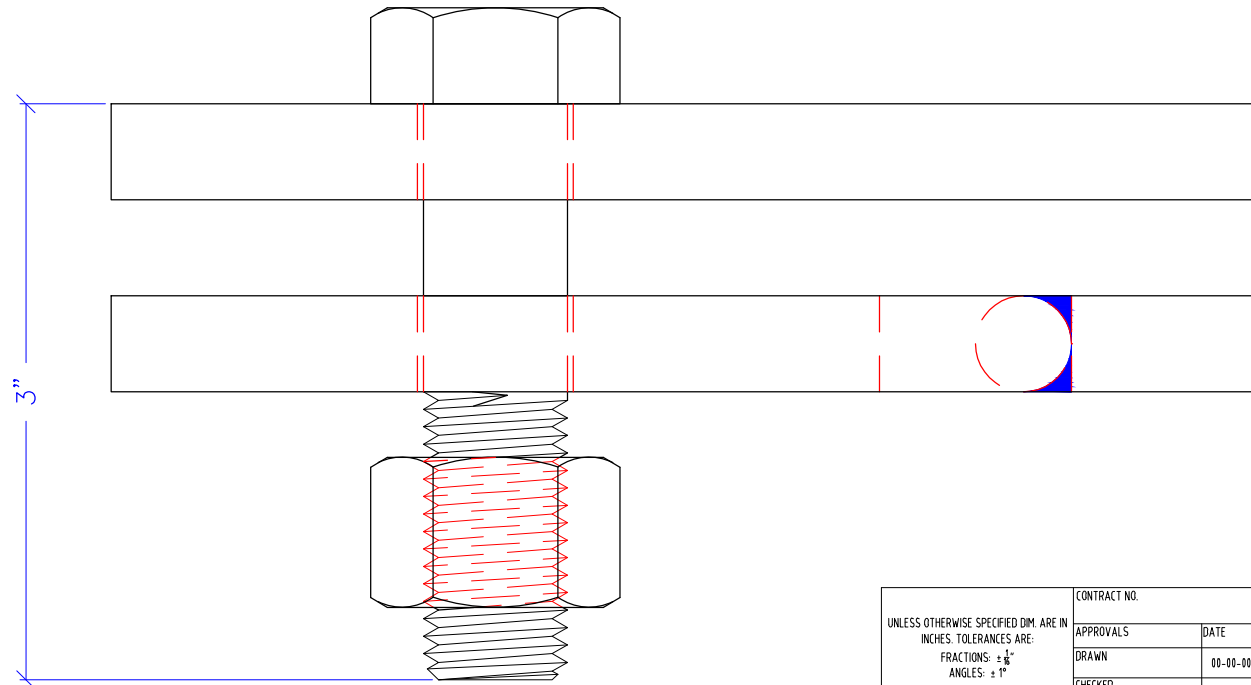
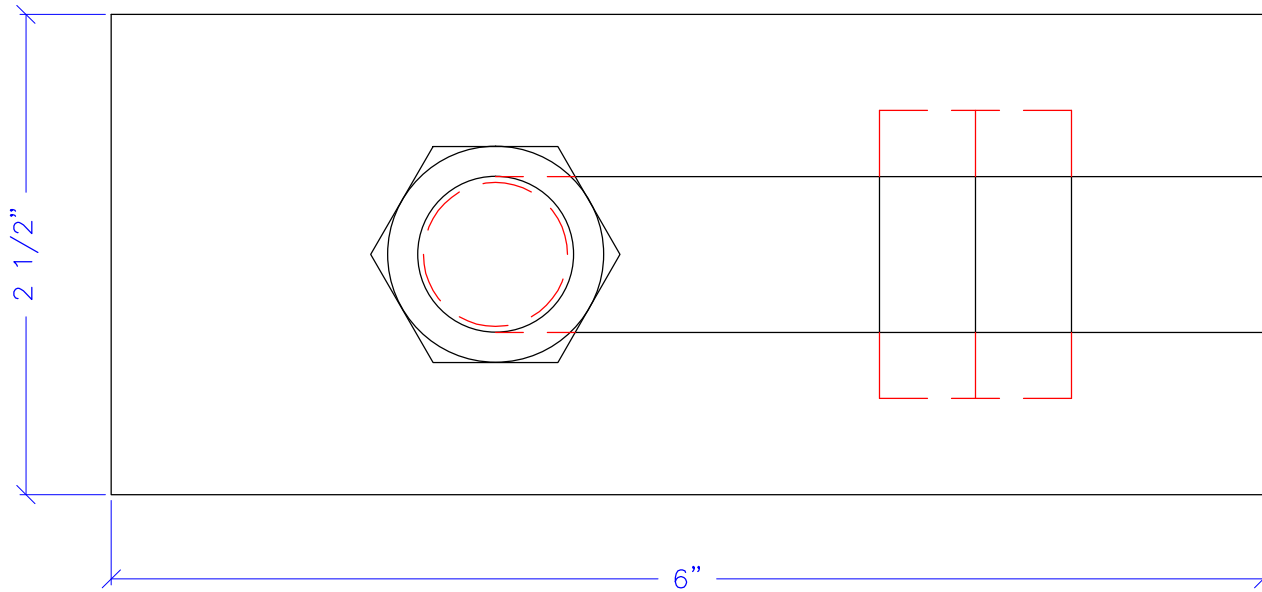

UNLESS OTHERWISE SPECIFIED DIM. ARE IN INCHES. TOLERANCES ARE: FRACTIONS: $\pm \frac{1}{8}$ " ANGLES: $\pm 1^\circ$	CONTRACT NO.		SPECTRUM CONCRETE PRODUCTS, LLC.	
	APPROVALS	DATE		
	DRAWN	00-00-00	TITLE:	LR CLIP / FALSEWORK CONNECTOR
	CHECKED		SIZE	A
MATERIAL	ISSUED	DWG NO.	REV.	
		SCALE	SHEET	

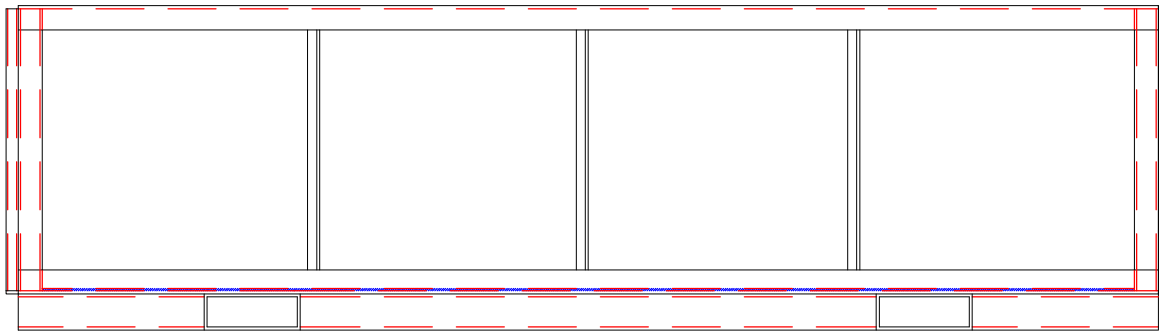

FRONT VIEW

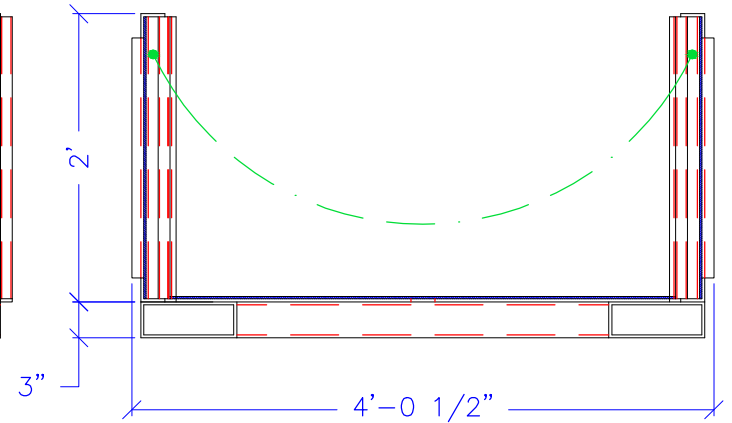

4'-0 1/2"
SIDE VIEW

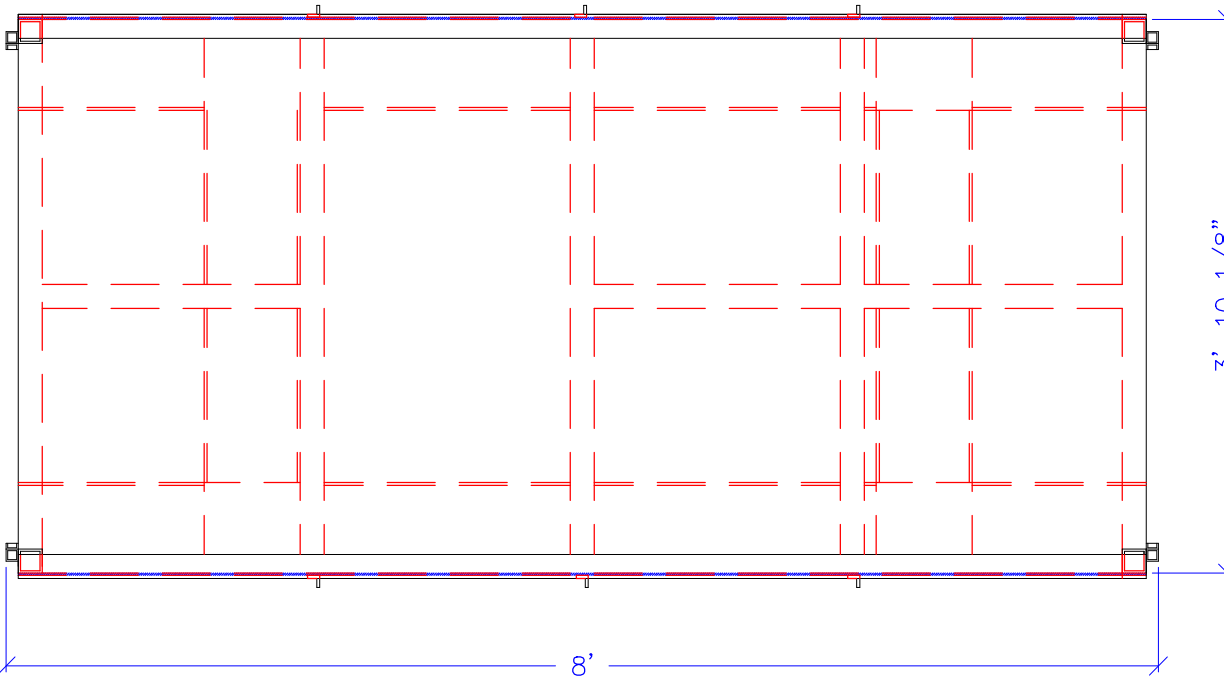

8'
TOP VIEW

UNLESS OTHERWISE SPECIFIED DIM. ARE IN INCHES. TOLERANCES ARE: FRACTIONS: $\pm \frac{1}{8}"$ ANGLES: $\pm 1^\circ$	CONTRACT NO.		SPECTRUM CONCRETE PRODUCTS, LLC.	
	APPROVALS	DATE		
	DRAWN	00-00-00	TITLE:	MATERIAL BIN
	CHECKED		SIZE	DWG NO.
MATERIAL	ISSUED		A	
			SCALE	SHEET

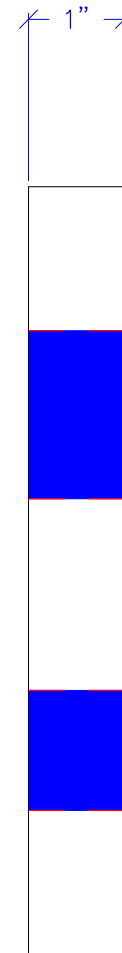
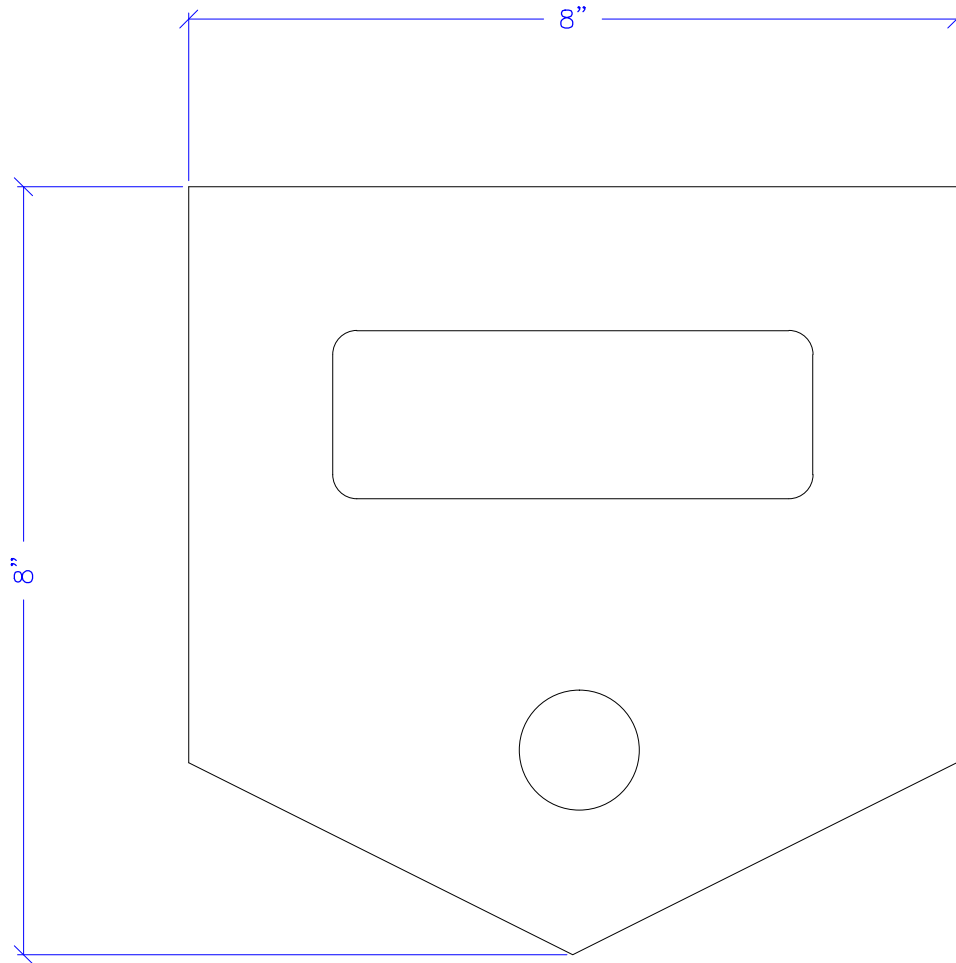

UNLESS OTHERWISE SPECIFIED DIM. ARE IN INCHES. TOLERANCES ARE: FRACTIONS: $\pm \frac{1}{16}$ " ANGLES: $\pm 1^\circ$	CONTRACT NO.		SPECTRUM CONCRETE PRODUCTS, LLC.	
	APPROVALS	DATE		
	DRAWN	00-00-00	TITLE:	PICKING EYE PLATE
	CHECKED		SIZE	A
MATERIAL	ISSUED	SCALE	DWG NO.	REV.
				SHEET

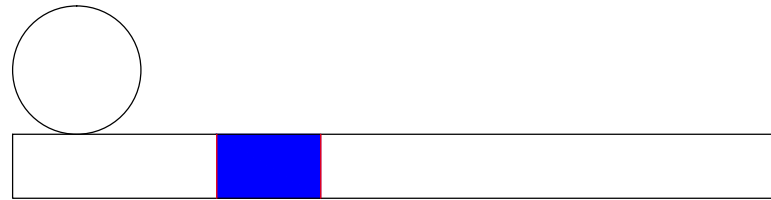
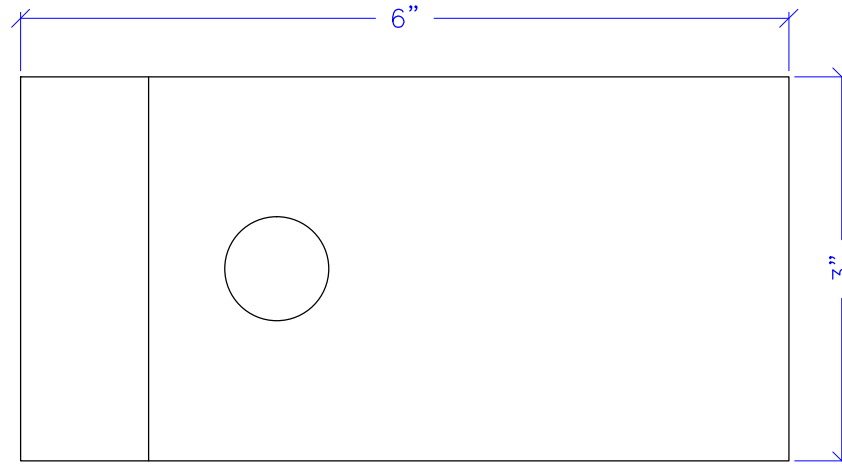

UNLESS OTHERWISE SPECIFIED DIM. ARE IN INCHES. TOLERANCES ARE: FRACTIONS: $\pm \frac{1}{16}$ " ANGLES: $\pm 1^\circ$	CONTRACT NO.		SPECTRUM CONCRETE PRODUCTS, LLC.	
	APPROVALS	DATE		
	DRAWN	00-00-00	TITLE: PLATE CLIP	
	CHECKED		SIZE A	DWG NO.
MATERIAL	ISSUED		SCALE	SHEET

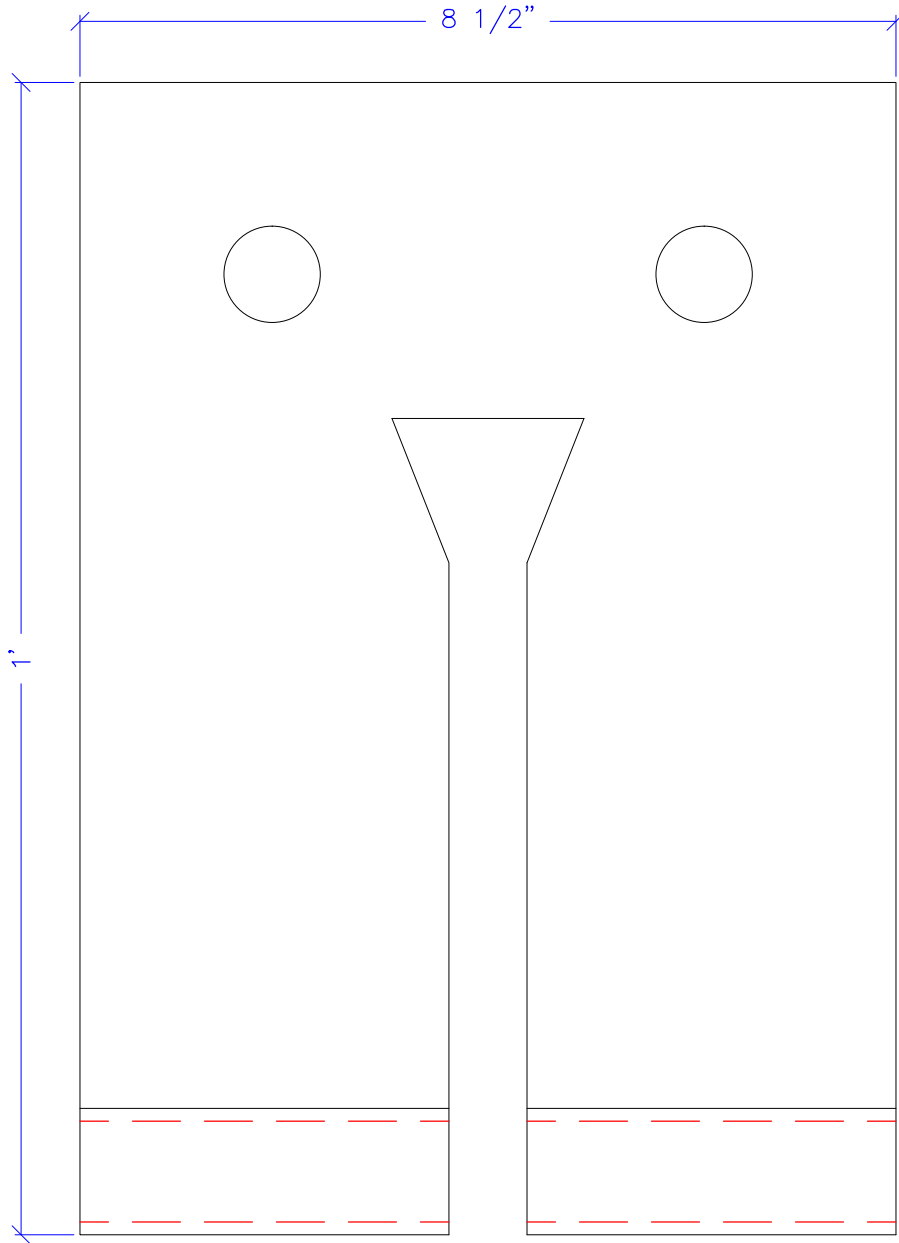
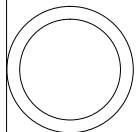
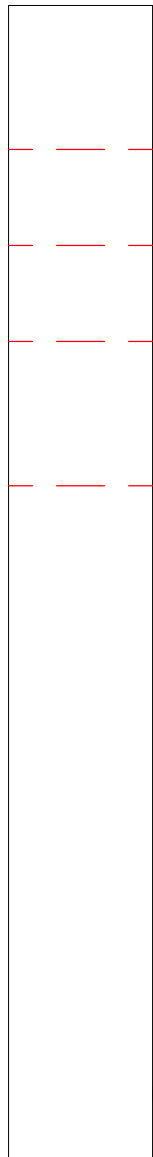

UNLESS OTHERWISE SPECIFIED DIM. ARE IN INCHES. TOLERANCES ARE: FRACTIONS: $\pm \frac{1}{16}$ " ANGLES: $\pm 1^\circ$	CONTRACT NO.		SPECTRUM CONCRETE PRODUCTS, LLC.	
	APPROVALS	DATE		
	DRAWN	00-00-00	TITLE:	PRE-STRESS BRACE PLATE
	CHECKED		SIZE	DWG NO.
MATERIAL	ISSUED		A	
			SCALE	SHEET

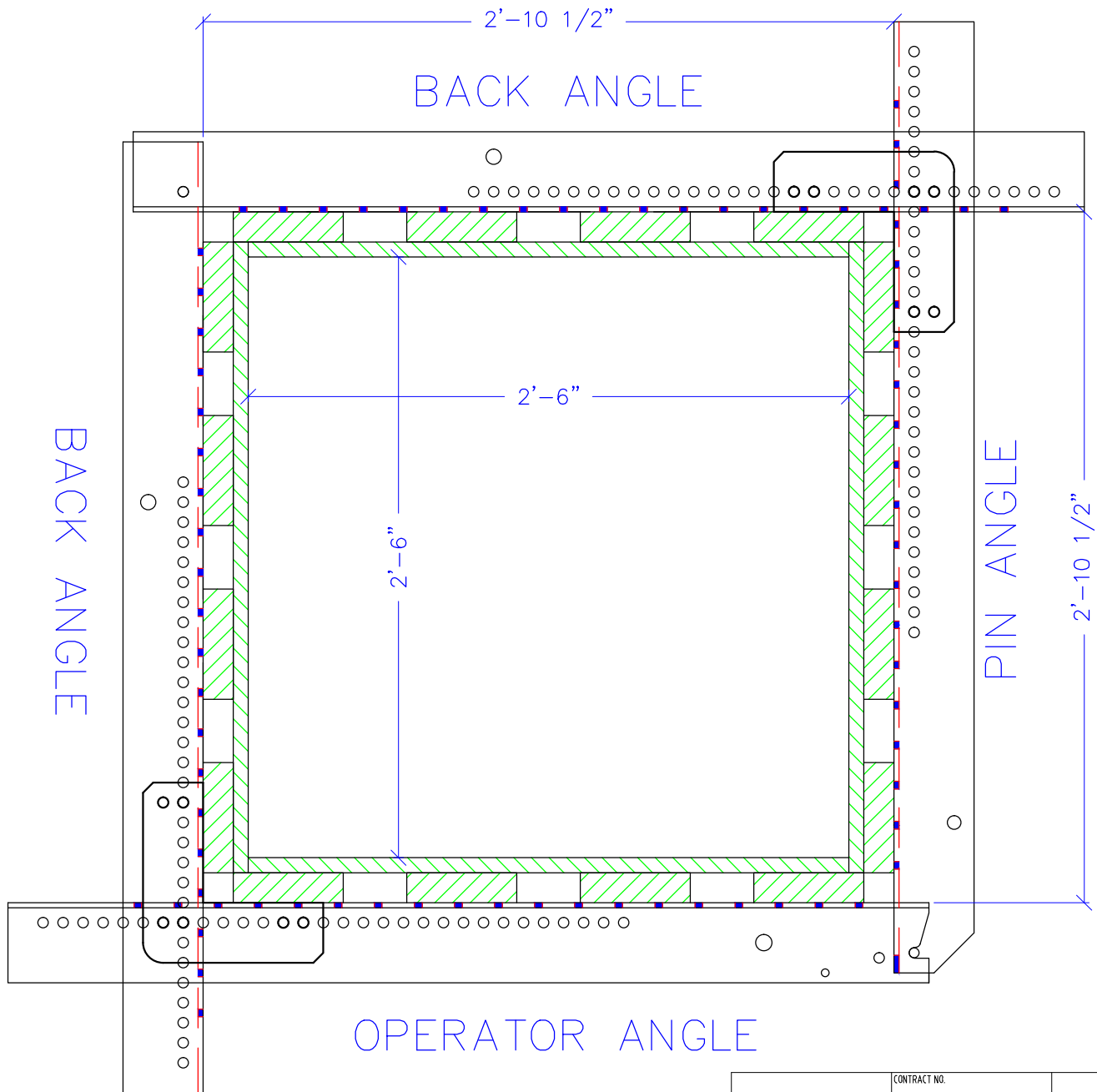

UNLESS OTHERWISE SPECIFIED DIM. ARE IN INCHES. TOLERANCES ARE: FRACTIONS: $\pm \frac{1}{16}$ " ANGLES: $\pm 1^\circ$	CONTRACT NO.		SPECTRUM CONCRETE PRODUCTS, LLC.	
	APPROVALS	DATE		
	DRAWN	00-00-00	TITLE:	RAPID LOCK COLUMN CLAMP
	CHECKED		SIZE	DWG NO.
MATERIAL	ISSUED		A	
			SCALE	SHEET

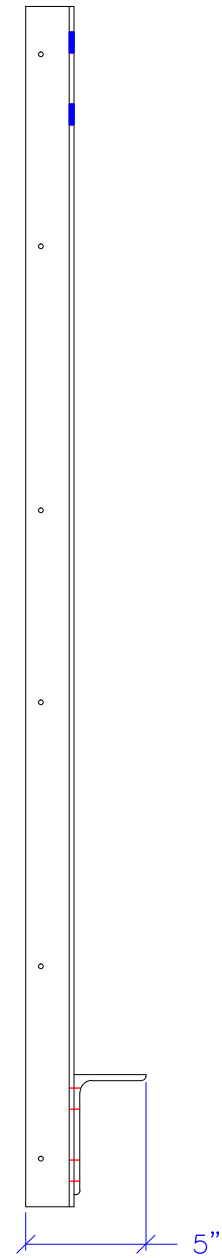
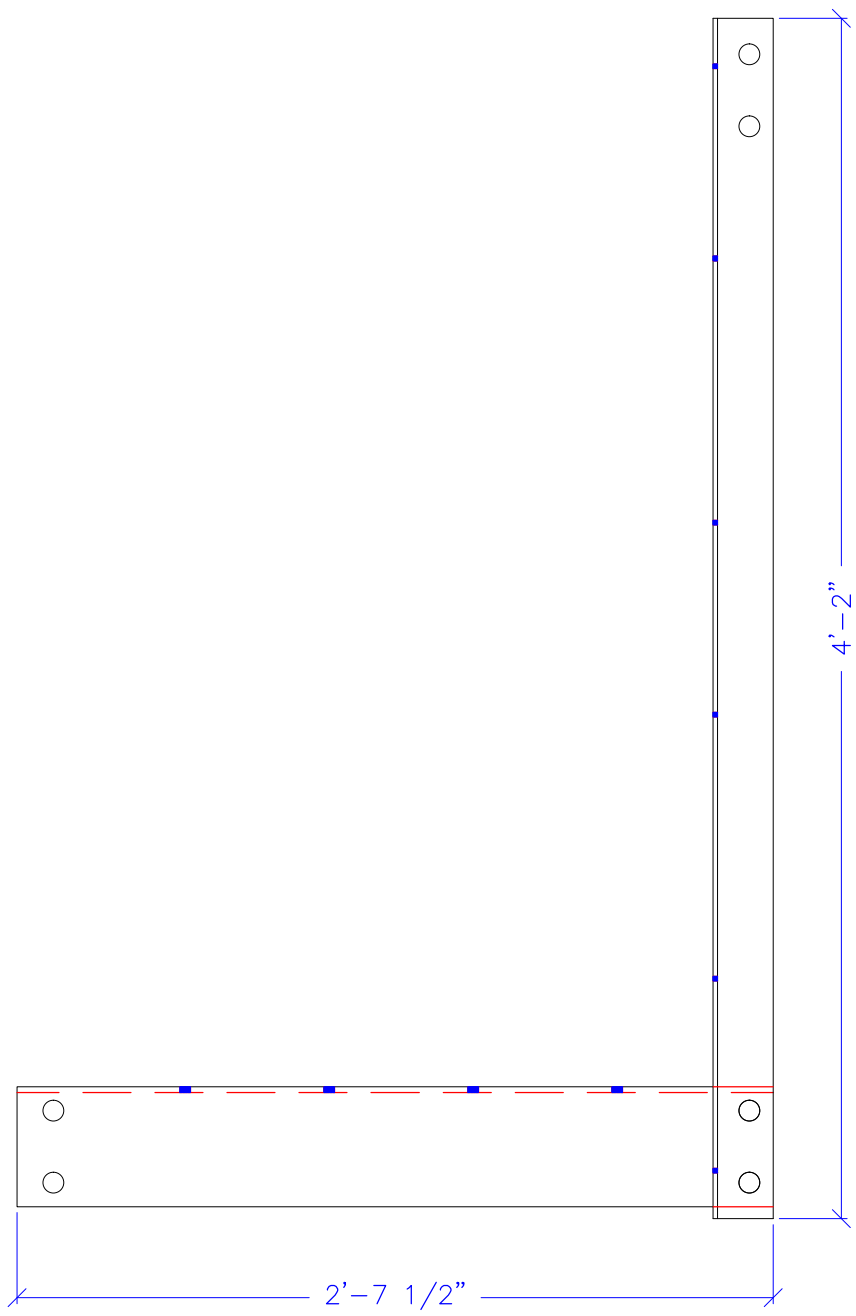

UNLESS OTHERWISE SPECIFIED DIM. ARE IN INCHES. TOLERANCES ARE: FRACTIONS: ± 1/16" ANGLES: ± 1°	CONTRACT NO.		SPECTRUM CONCRETE PRODUCTS, LLC.	
	APPROVALS	DATE		
	DRAWN	00-00-00	TITLE: RETAINING WALL SCAFFOLD BRACKET	
	CHECKED		SIZE A	DWG NO.
MATERIAL	ISSUED		SCALE	SHEET

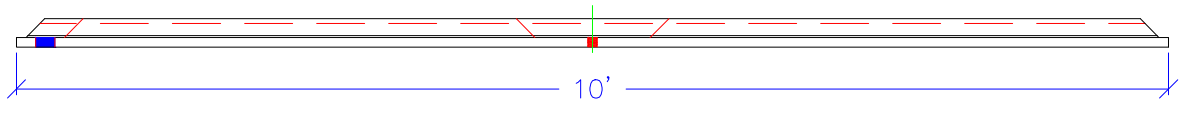
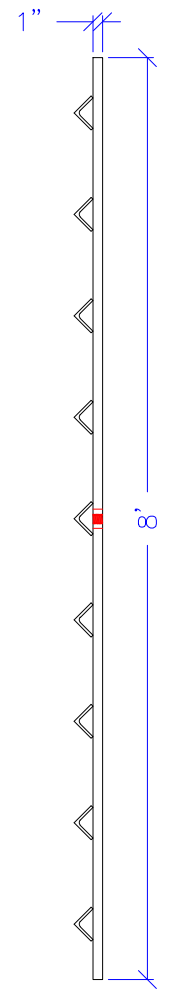
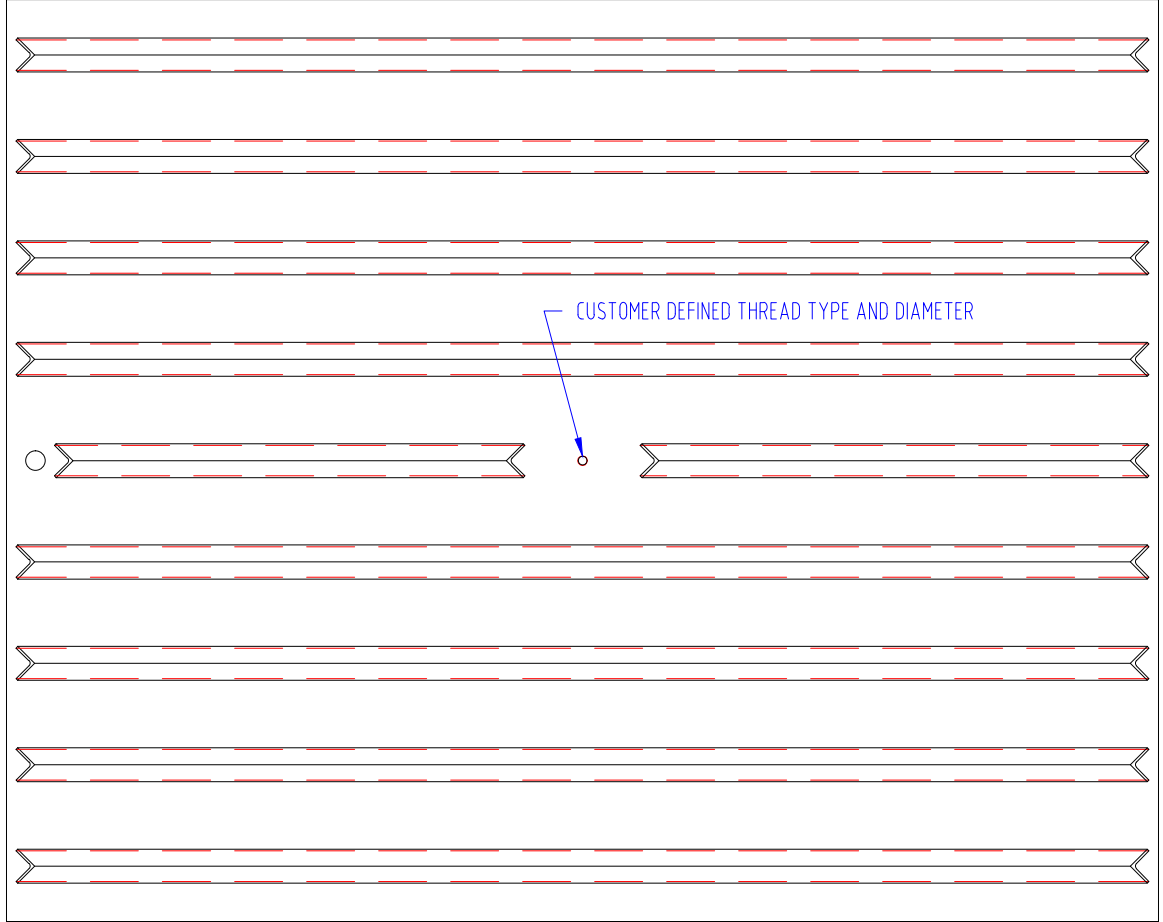

UNLESS OTHERWISE SPECIFIED DIM. ARE IN INCHES. TOLERANCES ARE: FRACTIONS: $\pm \frac{1}{16}$ " ANGLES: $\pm 1^\circ$	CONTRACT NO.		SPECTRUM CONCRETE PRODUCTS, LLC.	
	APPROVALS	DATE		
	DRAWN	00-00-00	TITLE: RUMBLE PLATE	
	CHECKED		SIZE A	DWG NO.
MATERIAL	ISSUED		SCALE	SHEET

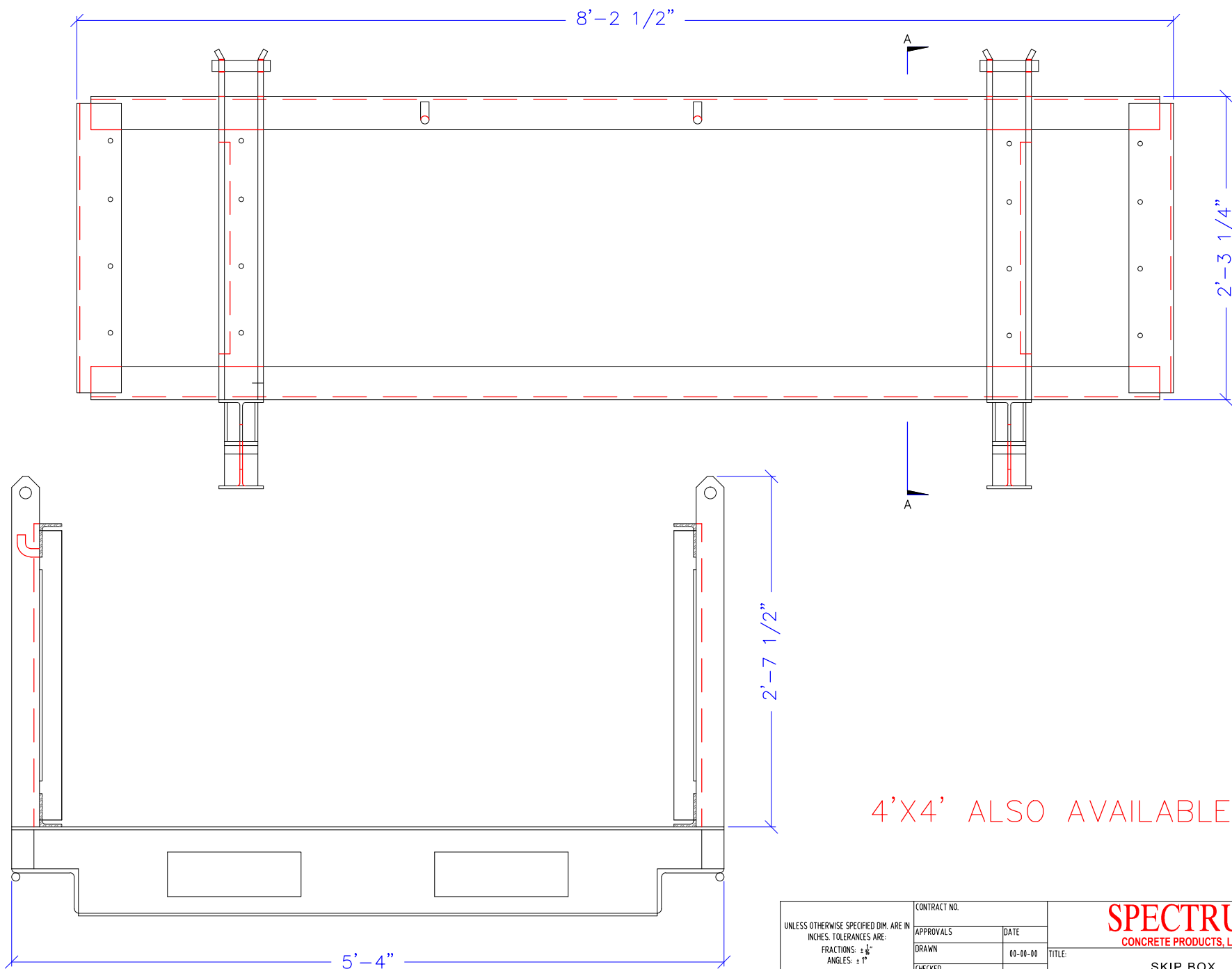

UNLESS OTHERWISE SPECIFIED DIM. ARE IN INCHES. TOLERANCES ARE: FRACTIONS: ± 1/16" ANGLES: ± 1°	CONTRACT NO.		SPECTRUM CONCRETE PRODUCTS, LLC.	
	APPROVALS	DATE		
	DRAWN	00-00-00	TITLE: SKIP BOX	
	CHECKED		SIZE A	DWG NO.
MATERIAL	ISSUED		SCALE	SHEET

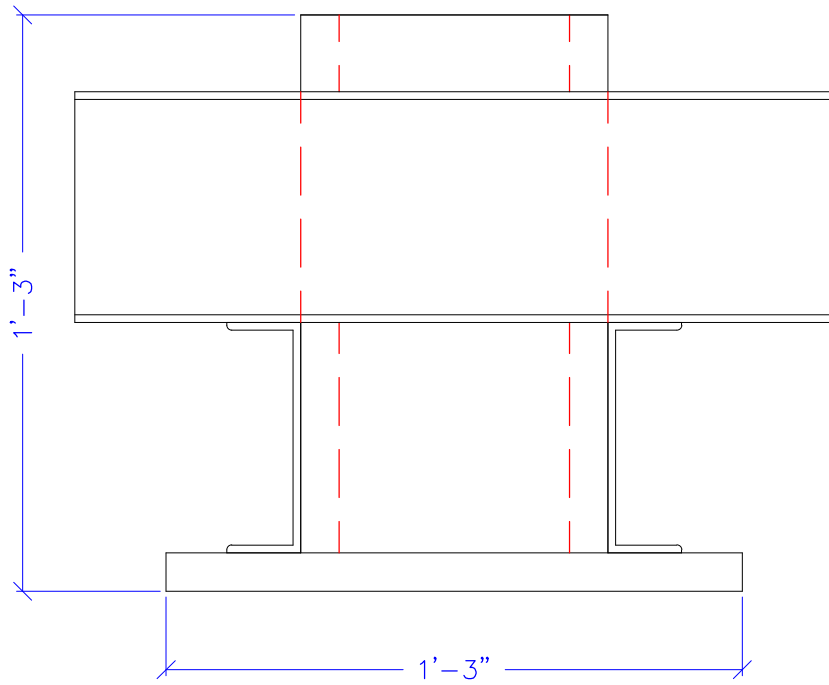

FRONT VIEW

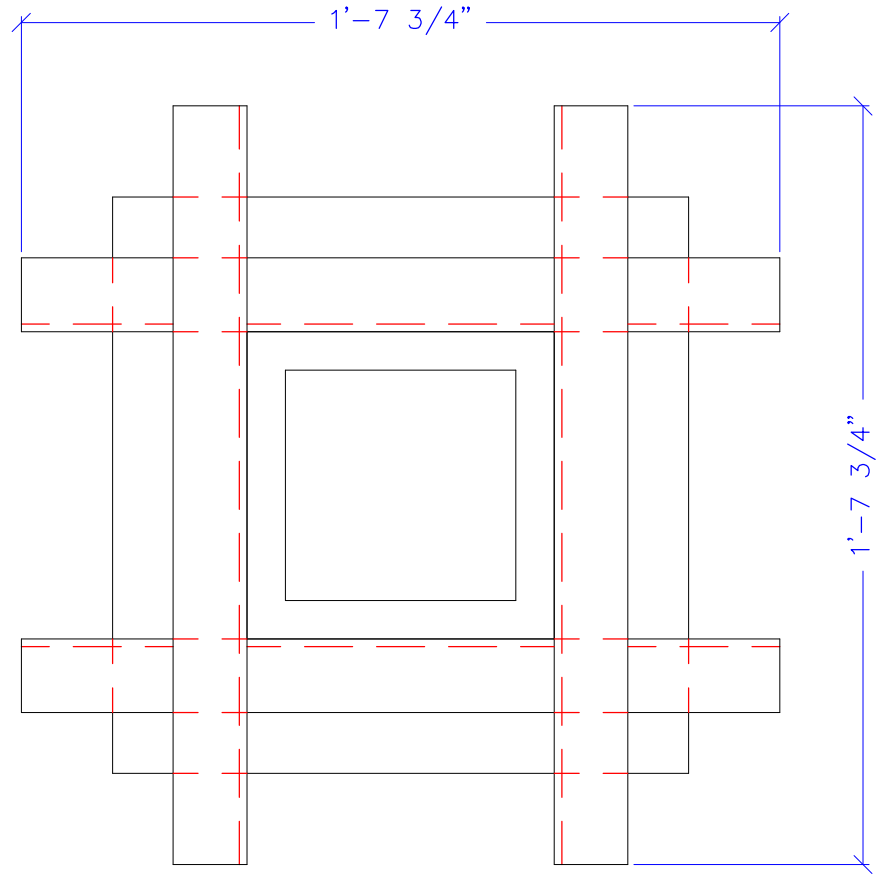

TOP VIEW

UNLESS OTHERWISE SPECIFIED DIM. ARE IN INCHES. TOLERANCES ARE: FRACTIONS: $\pm \frac{1}{16}$ " ANGLES: $\pm 1^\circ$	CONTRACT NO.		SPECTRUM CONCRETE PRODUCTS, LLC.	
	APPROVALS	DATE		
	DRAWN	00-00-00	TITLE:	TOWER CRANE EXTENSION
	CHECKED		SIZE	A
MATERIAL	ISSUED	DWG NO.		REV.
		SCALE		SHEET

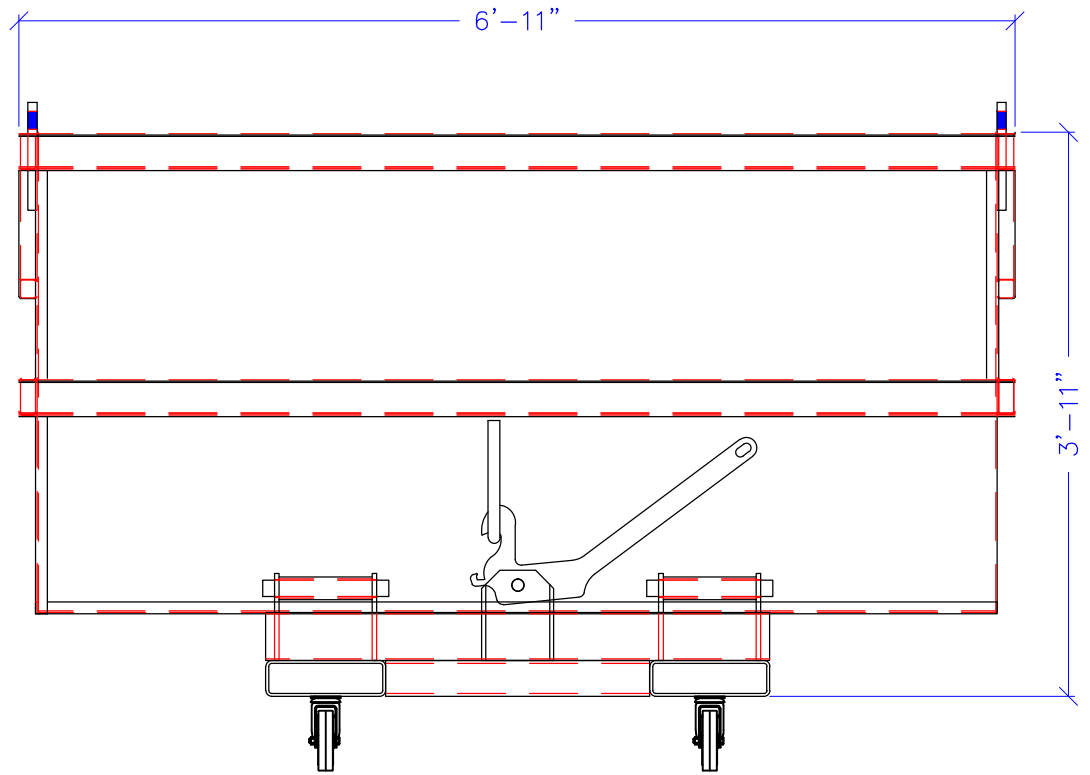
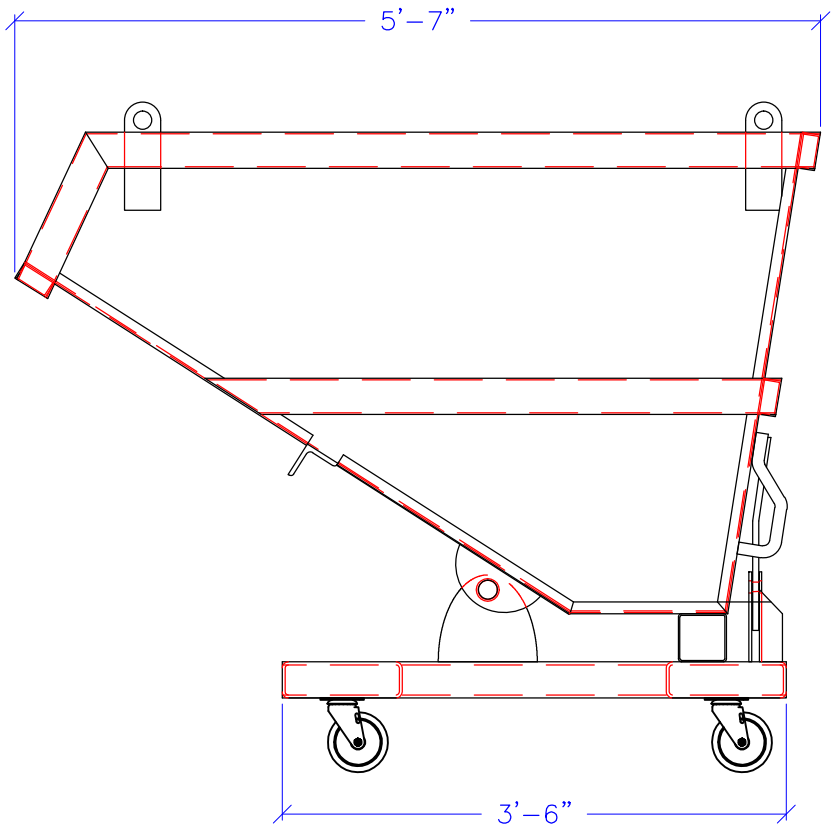

UNLESS OTHERWISE SPECIFIED DIM. ARE IN INCHES. TOLERANCES ARE: FRACTIONS: $\pm \frac{1}{16}$ " ANGLES: $\pm 1^\circ$	CONTRACT NO.		SPECTRUM CONCRETE PRODUCTS, LLC.	
	APPROVALS	DATE		
	DRAWN	00-00-00	TITLE: TRASH HOPPER	
	CHECKED		SIZE A	DWG NO.
MATERIAL	ISSUED		SCALE	SHEET

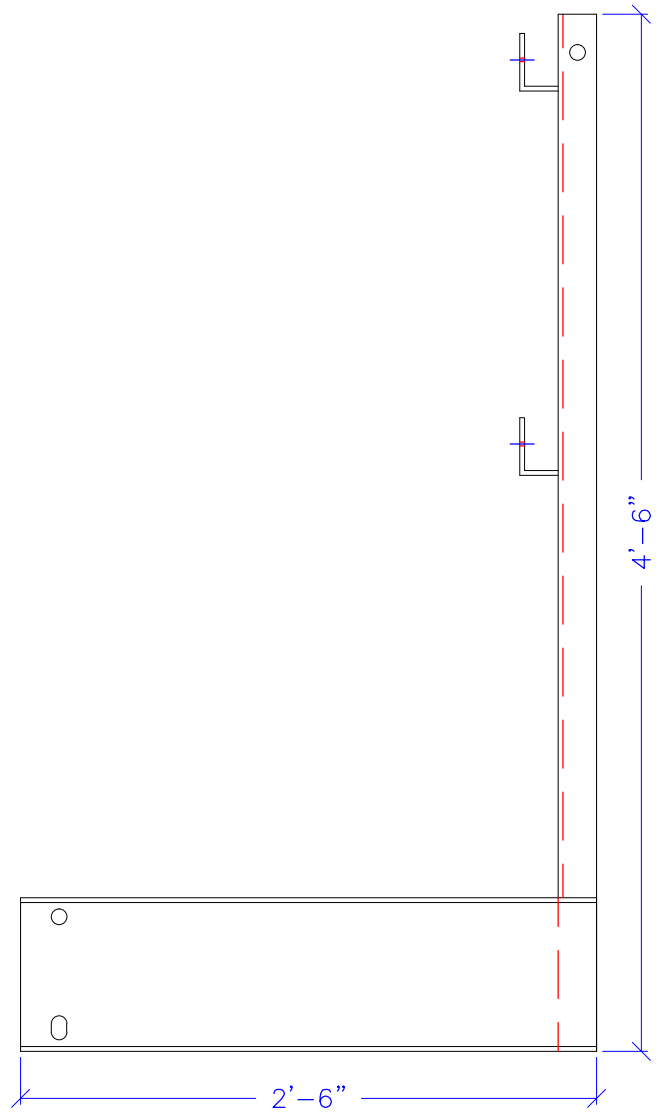

UNLESS OTHERWISE SPECIFIED DIM. ARE IN INCHES. TOLERANCES ARE: FRACTIONS: $\pm \frac{1}{16}$ " ANGLES: $\pm 1^\circ$	CONTRACT NO.		SPECTRUM CONCRETE PRODUCTS, LLC.	
	APPROVALS	DATE		
	DRAWN	00-00-00	TITLE: WALL PANEL SCAFFOLD BRACKET	
	CHECKED		SIZE A	DWG NO.
MATERIAL	ISSUED		SCALE	SHEET

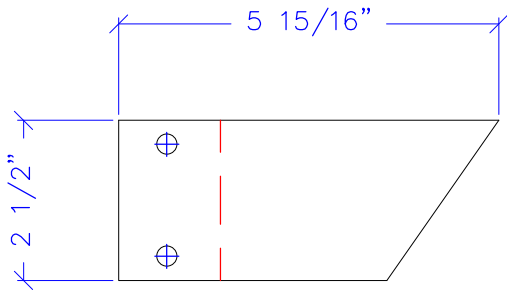
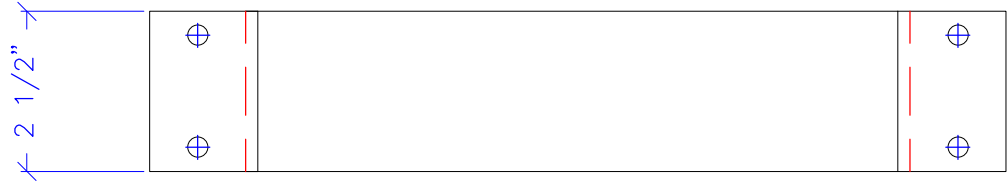
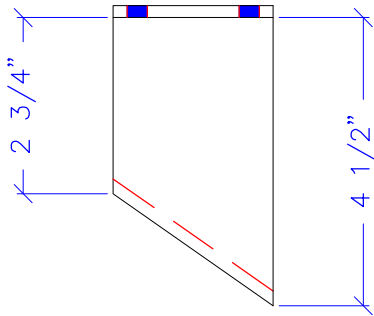

PLATE DETAIL



TOP VIEW



SIDE VIEW

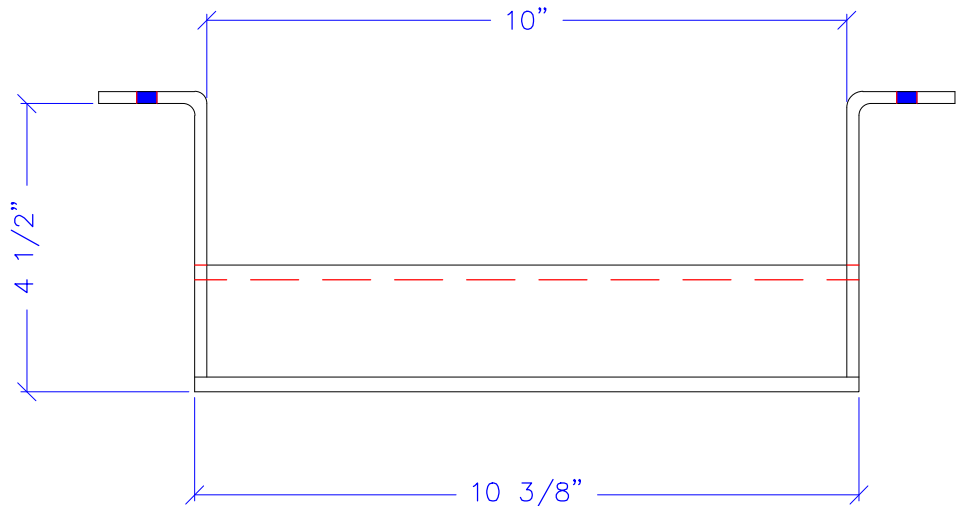

FRONT VIEW

UNLESS OTHERWISE SPECIFIED DIM. ARE IN INCHES. TOLERANCES ARE: FRACTIONS: $\pm \frac{1}{16}$ " ANGLES: $\pm 1^\circ$	CONTRACT NO.		SPECTRUM CONCRETE PRODUCTS, LLC.	
	APPROVALS	DATE		
	DRAWN	00-00-00	TITLE:	WHEEL CHOCK HOLDER
	CHECKED		SIZE	DWG NO.
MATERIAL	ISSUED		A	
			SCALE	SHEET

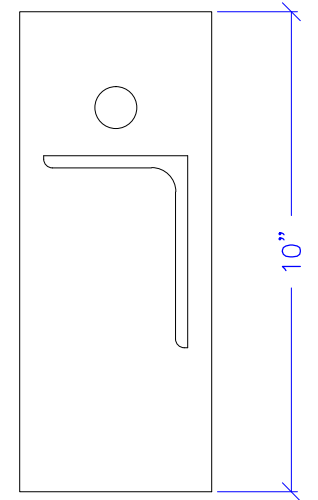
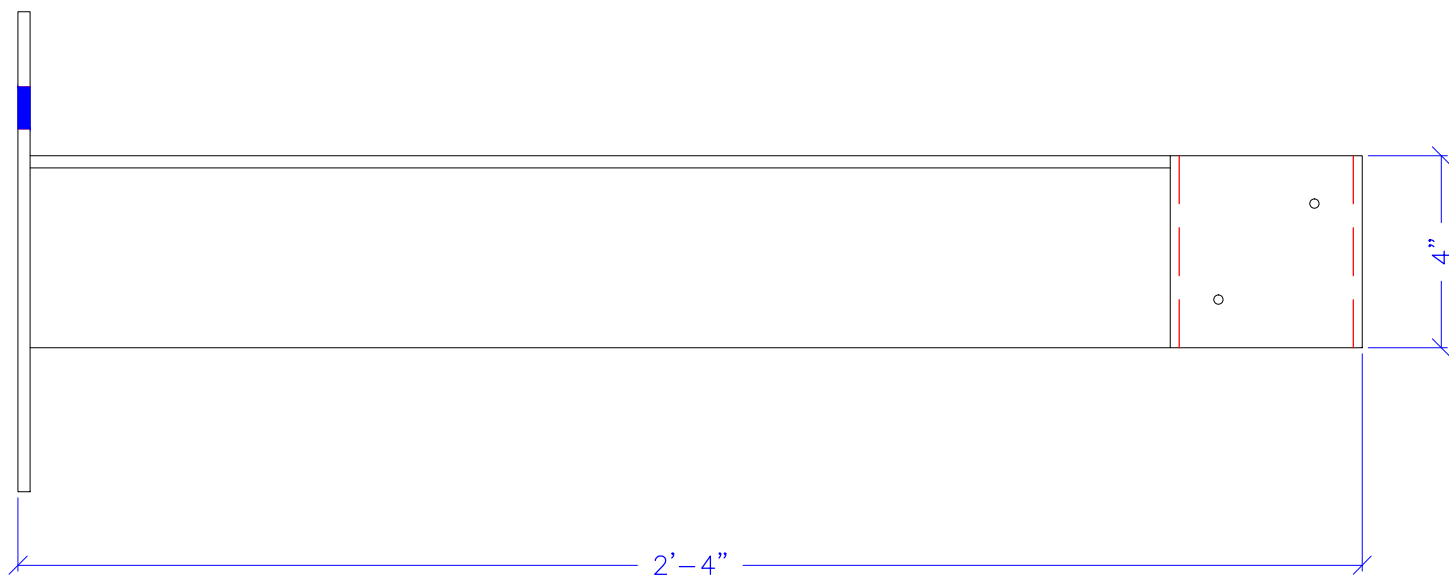
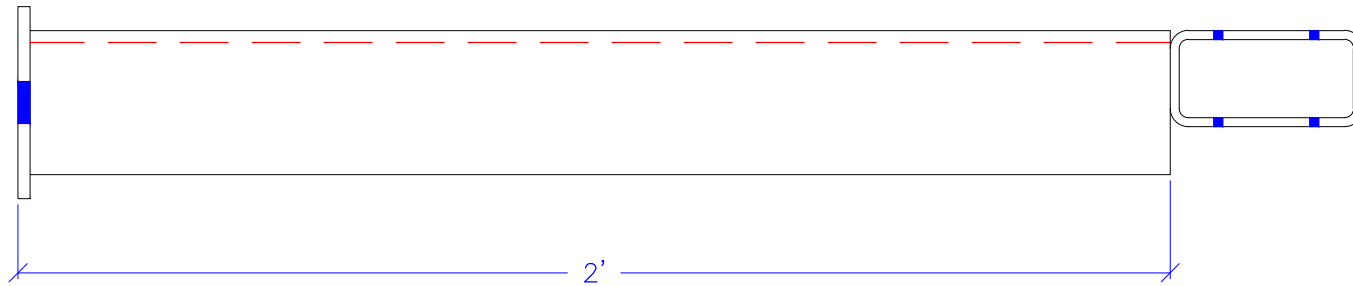

UNLESS OTHERWISE SPECIFIED DIM. ARE IN INCHES. TOLERANCES ARE: FRACTIONS: $\pm \frac{1}{16}$ " ANGLES: $\pm 1^\circ$	CONTRACT NO.		SPECTRUM CONCRETE PRODUCTS, LLC.	
	APPROVALS	DATE		
	DRAWN	00-00-00	TITLE:	WORKING PLATFORM BRACKETS
	CHECKED		SIZE	DWG NO.
MATERIAL	ISSUED		A	
			SCALE	SHEET

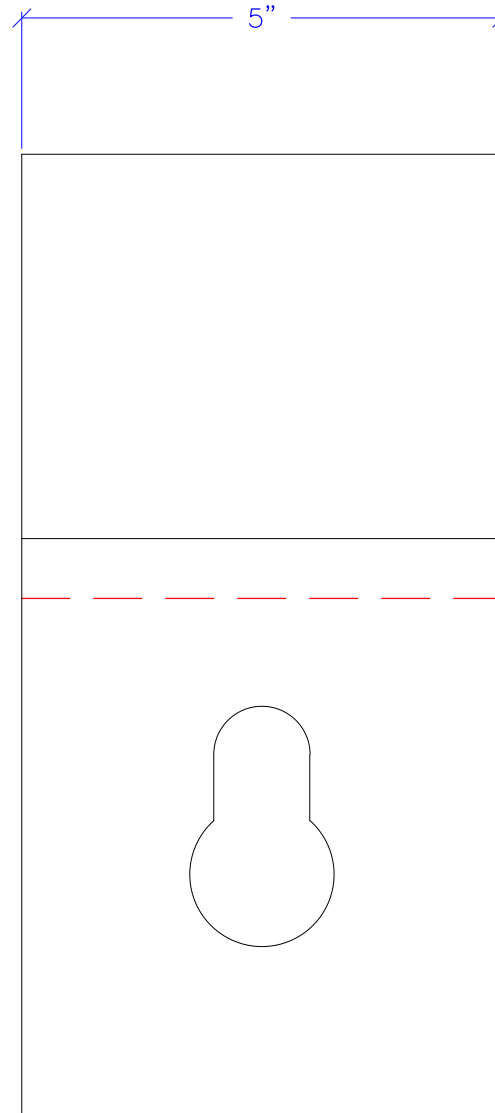
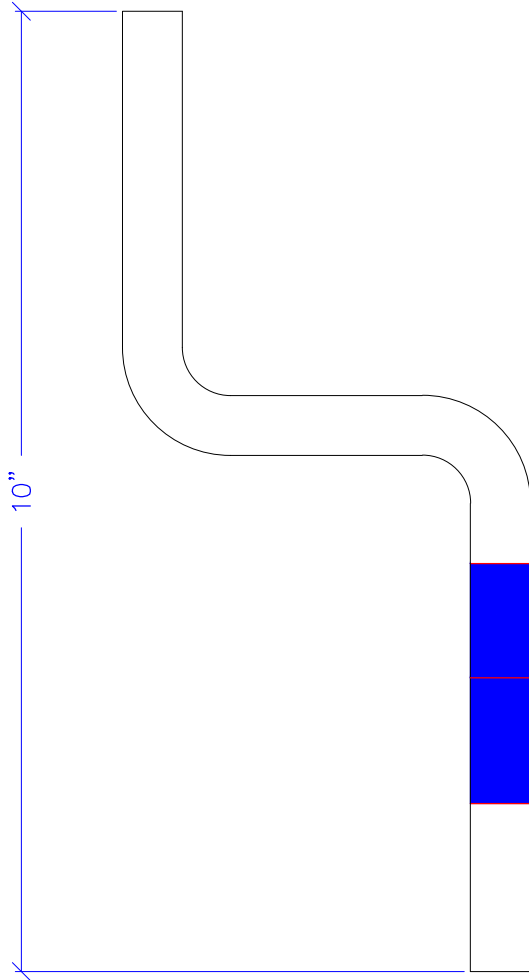

UNLESS OTHERWISE SPECIFIED DIM. ARE IN INCHES. TOLERANCES ARE: FRACTIONS: $\pm \frac{1}{16}$ " ANGLES: $\pm 1^\circ$	CONTRACT NO.		SPECTRUM CONCRETE PRODUCTS, LLC.	
	APPROVALS	DATE		
	DRAWN	00-00-00	TITLE: Z BRACKET	
	CHECKED		SIZE A	DWG NO.
MATERIAL	ISSUED		SCALE	SHEET