



TAPER TIES (STD)

STANDARD — TECHNICAL DATA SHEET

DESCRIPTION:

Standard Coil, NC, or Acme thread Taper Ties. Available in 1/2" and 3/4" diameter thread, and with a 1/2" keyplate slot.

APPLICATION:

Used in poured-in-place concrete forms. When used with Nut Washers, Wing Nuts, or Plate Washers, these Taper Ties can hold loads as specified in the table below.

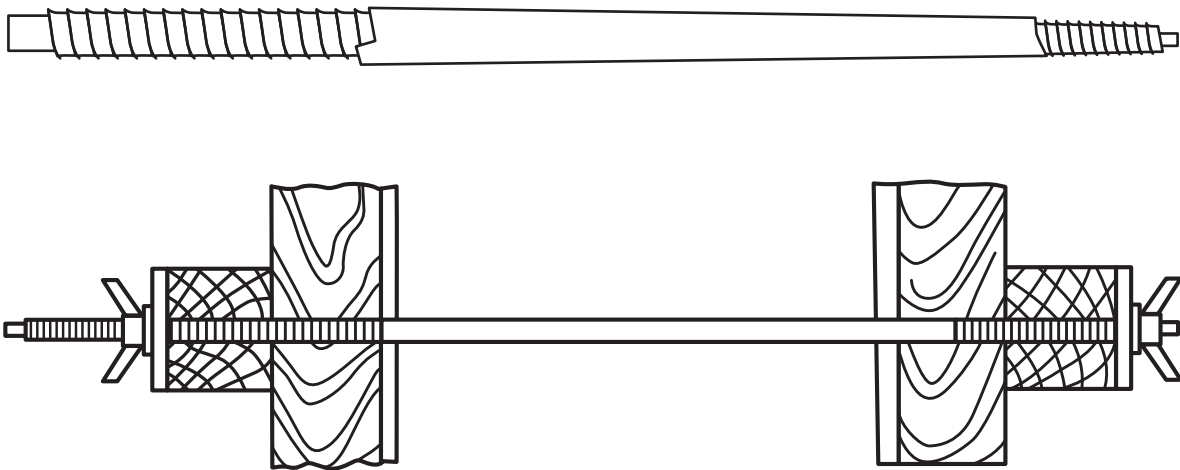

SAFE LOAD	LARGE END	SMALL END	TIE LENGTH
6,000	3/4" X 10" COIL OR ACME THREAD	1/2" X 2" COIL OR ACME THREAD	34"
6,000	3/4" X 10" COIL OR ACME THREAD	1/2" X 2" COIL OR ACME THREAD	43"
6,000	3/4" X 10" COIL OR ACME THREAD	1/2" X 2" COIL OR ACME THREAD	52"
6,000	3/4" X 10" COIL OR ACME THREAD	1/2" X 2" COIL OR ACME THREAD	61"
4,500	3/4" X 10" COIL OR ACME THREAD	1/2" KEYPLATE SLOT	34"
4,500	3/4" X 10" COIL OR ACME THREAD	1/2" KEYPLATE SLOT	43"
4,500	3/4" X 10" COIL OR ACME THREAD	1/2" KEYPLATE SLOT	52"
4,500	3/4" X 10" COIL OR ACME THREAD	1/2" KEYPLATE SLOT	61"

SAFE WORKING LOAD IS APPROX. BASED ON A 2:1 SAFETY FACTOR

