



HEADER FORM BRACKET

TECHNICAL DATA SHEET

DESCRIPTION:

Header Form Brackets are used to support 2"x4" lumber or headers on screed posts and steel stakes. These brackets are heavy duty with 3"x3" backing plate. They are galvanized and are included with a Hex Head Screw for securing the stakes.

APPLICATION:

Position the bracket at the desired height and tighten the set screw, then nail the header to the bracket using the holes provided in the bracket plate.

COMPATIBLE WITH:

- 3/4" Round Steel Stakes • Nail Point Posts • Screed Point Posts
- 3/4" Square Steel Stakes • Screed Pad Posts • Screw Point Posts

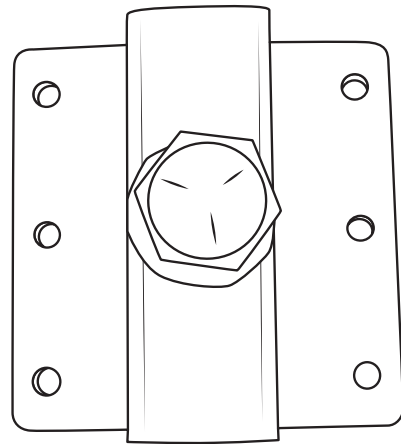
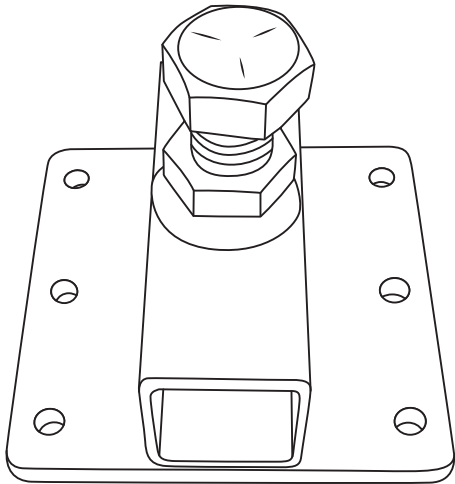

PRODUCT CODE	WEIGHT	PACKAGED
HDRBKT	1.0 / EACH	EACH

