



SNAP JACKS

TECHNICAL DATA SHEET

DESCRIPTION:

Snap Jack Single Waler Scaffold Brackets.

APPLICATION:

Snap Jacks provide the framework for 2x10 planks to make a convenient working platform. The built-in guardrail receptacle makes it easier to install a safe and economical safety rail, spaced at 8ft. maximum centers.

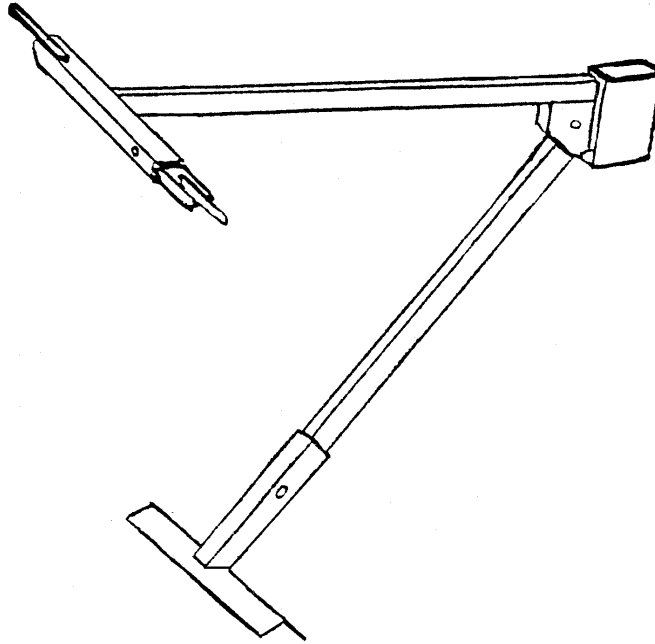

PRODUCT CODE	WEIGHT
SNPJCK	17.0 LBS. EACH

